

LxT Manual for SoundTrack LxT[®] & SoundExpert[™] LxT

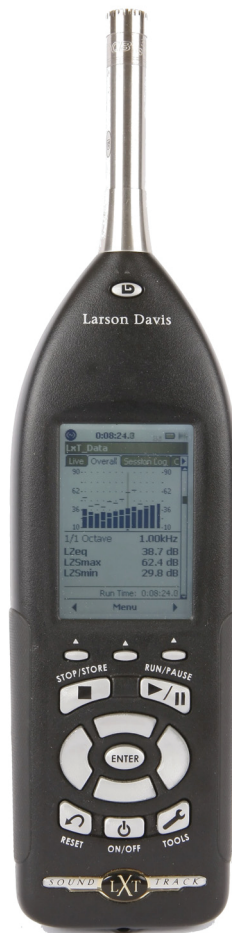

Larson Davis

LxT Manual

for

SoundTrack LxT[®]
& SoundExpert[®] LxT

Copyright

Copyright 2017 by PCB Piezotronics, Inc. This manual is copyrighted, with all rights reserved. The manual may not be copied in whole or in part for any use without prior written consent of PCB Piezotronics, Inc.

Trademarks

PCB®, *SoundTrack LxT®* and *SoundExpert®* are registered trademarks of PCB Piezotronics, Inc. *Swithcraft®* is a registered trademark of Switchcraft, Inc. All other trademarks are property of their respective owners.

Disclaimer

The following paragraph does not apply in any state or country where such statements are not agreeable with local law:

Even though PCB Piezotronics, Inc. has reviewed its documentation, PCB Piezotronics, Inc. makes no warranty or representation, either expressed or implied, with respect to this instrument and documentation, its quality, performance, merchantability, or fitness for a particular purpose. This documentation is subject to change without notice, and should not be construed as a commitment or representation by PCB Piezotronics, Inc.

This publication may contain inaccuracies or typographical errors. PCB Piezotronics, Inc. will periodically update the material for inclusion in new editions. Changes and improvements to the information described in this manual may be made at any time.

Record of Serial Number and Purchase Date

LxT Model: LxT1 LxT2 **Serial Number:** _____
Preamplifier Model: _____ **Serial Number:** _____
Microphone Model: _____ **Serial Number:** _____

Recycling

PCB Piezotronics, Inc. is an environmentally friendly organization and encourages our customers to be environmentally conscious. When this product reaches its end of life, please recycle the product through a local recycling center or return the product to:



PCB Piezotronics, Inc.
Attn: Recycling Coordinator
1681 West 820 North
Provo, Utah, USA 84601-1341

where it will be accepted for disposal.

Warranty

For warranty information, refer to our *Terms and Conditions of Sale* on our website at www.larsondavis.com/TermsConditions.aspx.

Table of Contents

Chapter 1	LxT Features	1-1
	SoundTrack LxT	1-1
	SoundExpert LxT	1-5
Chapter 2	Overview	2-1
	LxT Components	2-1
	Summary of Displays and Icons	2-6
	Navigating and Selecting	2-8
	Basic Run Functions	2-9
	Tab and Setting Displays	2-9
Chapter 3	Preparing for First Use	3-1
	Unpacking and Inspection	3-1
	Connecting the Microphone and Preamplifier	3-2
	Connecting the Preamplifier to the LxT	3-3
	Disconnecting the Preamplifier from the LxT	3-4
	Powering the SoundTrack LxTâ	3-4
Chapter 4	Basic Measurement Setup	4-1
	Measurement Settings Tabs	4-1
Chapter 5	Data Display	5-1
	Data Labels	5-1
	Tabbed Display	5-1
	Live Tab	5-3
	Overall Tab	5-8
	Session Log Tab	5-20
	View Spectrum Normalized (Optional)	5-21
Chapter 6	Making Measurements	6-1
	Preparation	6-1
	Positioning the LxT	6-1
	Performing Measurements	6-2
	Storing Measurements	6-7
	Data Storage After Improper Shutdown	6-9

Chapter 7	Calibration	7-1
	Calibration Overview	7-1
	Control Panel - Calibrate	7-2
	Acoustic Calibration	7-4
	Sensitivity Tab	7-12
	Calibration Without Preamplifier	7-13
	Certification	7-15
Chapter 8	Voice Recording	8-1
	Launching the Voice Recorder Dialog	8-1
	Making a Voice Recording	8-2
	Playing a Voice Recording	8-3
	Storing Voice Recordings	8-3
Chapter 9	Time History	9-1
	Parameters Logged	9-1
	Time History Setup	9-3
	Time History Tab	9-5
	Link to Measurement History Display	9-8
	Markers	9-9
Chapter 10	Measurement History	10-1
	Enabling Measurement History	10-1
	Continuous and Timer Modes	10-2
	Timed Stop Mode	10-3
	Manual and Stop When Stable Modes	10-3
	Display of Measurement History	10-3
	Link to Time History	10-12
Chapter 11	Data Explorer	11-1
	Control Panel - Data Explorer	11-1
Chapter 12	System Properties	12-1
	Control Panel - System Properties	12-1
	Device	12-2
	Time	12-3
	Power	12-4
	Preferences	12-8
	Localization	12-15
	Displays	12-17

	Options	12-21
Chapter 13	Lock/Unlock the LxT	13-1
	Control Panel - Lock	13-1
	Fully Locked	13-4
	Locked With Auto-Store	13-5
	Locked With Manual-Store	13-7
	Calibration When The LxT Is Locked	13-7
Chapter 14	About	14-1
	Control Panel - About	14-1
	About Tab	14-1
	Standards	14-2
	Options	14-3
	User	14-3
Chapter 15	System Utilities	15-1
	System Utilities	15-1
	File System	15-2
Chapter 16	Parameters Measured	16-1
	Basic Sound Level Measurements	16-1
	Sound Exposure Metrics Measured	16-3
	Statistical Metrics Measured	16-4
	Community Noise Parameters	16-4
	Exceedance Counters	16-5
	Miscellaneous Parameters	16-5
Chapter 17	Memory Utilization	17-1
	Out Of Memory Stop	17-1
	Overall Data	17-1
	Session Log	17-1
	Measurement History	17-1
	Time History	17-2
	Voice Messages	17-2
Chapter 18	Upgrading Firmware and Options	18-1
	SLM Utility-G3	18-1
	Upgrading LxT Firmware	18-1
	Upgrading LxT Options	18-4

Appendix A	Technical Specifications	A-1
	Standards Met by LxT	A-1
	LxT Specifications	A-2
	Electromagnetic Emission	A-15
	1/1 and 1/3 Octave Filters	A-17
	Position of Instrument and Operator	A-20
	Frequency Response	A-21
	Microphone Preamplifier Specifications	A-44
	Vibration Sensitivity	A-60
Appendix B	Testing to IEC61672-1	B-1
	Sections 5, 6, 7 and 9 (except 9.3)	B-1
	LxT1	B-8
	LxT2	B-13
Appendix C	Glossary and Formulas	C-1

LxT Features

This chapter describes the features for the SoundTrack LxT[®] and SoundExpert[®] LxT sound level meters.

SoundTrack LxT

The following sections describe the features for the SoundTrack LxT.

Hardware Features

The Larson Davis SoundTrack LxT has the following features:

- Precision integrating sound level meter
- 2 GB unformatted standard data memory
- 160 X 240 pixel LCD display with backlight and icon-driven user interface
- Silent Touch elastomeric keypad
- Large dynamic range
- Jack for AC/DC output or headset (ACC003)
- Preamplifier can drive a 61 m (200 ft.) microphone extension cable (EXC200)
- 4-AA batteries provide 16 hour operating time
- USB 2.0 peripheral connector
- Field-upgradeable firmware
- Windscreen (WS001)

Basic Measurements

- SPL, Leq, Lmax, Lmin, SEL, Lpeak, Lpeak(max)
- RMS Detectors: Slow, Fast & Impulse
- RMS Frequency Weighting: A, C & Z
- Peak Frequency Weighting: A, C & Z
- L_N statistics: 6 user-selected values over the range (L_{0.01} through L_{99.99}) and Histogram tables
- 2 Sets of hygiene metrics: Lavg, TWA(x), Dose, ProjDose, Lep,d

- E, E8, E40
- SEA peak exposure
- 2 RMS event counters and 3 Peak event counters

Basic Operation

- Auto-Store with Auto-Reset
- Run Timer and Stop-When-Stable Control
- Real-time clock
- Start time, elapsed time and paused time
- Time stamping for Lmax, Lmin, Lpeak(max) metrics
- Session Log
- Lock functions
- Calibration with calibration history and list of calibrators
- Power management
- Status bar and About display
- Multiple language support
- Data files and Data Explorer
- Automatic data backup to prevent data loss on power failure
- Overall measurement

Available Options

- **LXT-OB1:** Real-time 1/1 Octave Frequency Analysis
- **LXT-OB3:** Real-time 1/3 & 1/1 Octave Frequency Analysis
- **LXT-LOG:** Automatic data logging with intervals from 1 second to 24 hours
- **LXT-HSLOG:** Extends data logging (LXT-LOG) with intervals down to 100 milliseconds
- **LXT-ENV:** Measurement History Environmental Data Logging
- **LXT-CN:** Community Noise

- **LXT-DVA:** Digital Voice Annotation (includes headset ACC003)

Standard Accessories

The LxT is delivered with the standard accessories described below.

- One of the following preamplifier/microphone combinations:
 - **PRMLXT1** preamplifier with a **377B02** microphone
 - **PRMLXT1L** preamplifier with a **377B02** microphone
 - **PRMLXT2B** preamplifier with a **375B02** microphone
 - **PRMLXT2L** preamplifier with a **375B02** microphone.
- **SWW-SLM-UTILG4** SLM Utility-G4 software
- **SWW-SLM-UTILG3** SLM Utility-G3 software
- **WS001** Windscreen, 3 1/2 in. diameter
- Alkaline Batteries: 4-AA
- Lanyard

Optional Accessories

Equivalent Electrical Impedance Adaptor

An equivalent electrical impedance adaptor can be used in place of the microphone when a measurement is being made electrically. The adaptor is simply a series capacitor with the same capacitance as the microphone it is replacing. The following adaptors are available:

- **ADP002** 6.8pF adaptor for 1/4 in., 7pF microphone (377C01 or 377C10)
- **ADP005** 18pF adaptor for 1/2 in., 18pF microphone (375B02)
- **ADP090** 12pF adaptor for 1/2 in., 12 pF microphone (377B02)

Cables

Direct Input Cable or Adaptor

- **EXCXXX** Microphone extension cable, where XXX is the length in feet (XXX = 010, 020, 050, 066, 100 and 200 available)
- **CBL138** USB Cable
- **CBL139** AC/DC Output Cable

Power Supplies

- **PSA029** Universal AC Power Adaptor
- **PSA031** 12 Volt DC to USB Power Adaptor
- **BAT015** External battery powering device for the LxT, holding 4 or 8 D-sized alkaline 1.5 volt batteries to extend run time

Software

- **SWW-BLAZE-LXT** Blaze
- **SWW-DNA** DNA

Accessory Kits

- **LXT-ACC** including
 - **LXT-CCS** Hard Shell Case
 - **CAL200** Class I Calibrator
 - **PSA029** Power Supply
 - **CBL138** USB Cable
- **LXT-ACC1** including
 - **LXT-CCS** Hard Shell Case
 - **CAL150** Class I Calibrator
 - **PSA029** Power Supply
 - **CBL138** USB Cable

Other

- **377C20** 1/2" random incidence pre-polarized microphone, 50 mV/Pa, providing performance conforming to Class 1 sound level meter standards
- **ACC003** Headset with microphone for voice recording/ Playback (included LXT-DVA)

- **LXT-CCS** Storage Case

Environmental Protection

- **EPS2116** Environmental Shroud
- **EPS2106-2** Environmental Shroud
- **EPS2108-2** Environmental Shroud
- **EPS030-LXT** Environmental Case with one lead acid battery to be used with an external microphone tripod (the tripod is not included)

Tripods

- **TRP001** Instrument/Camera Tripod with ADP032 1/2 in. microphone clip. Use with EPS2108-2
- **TRP002** Microphone Stand with adjustable height and boom angle
- **TRP003** Support Tripod, heavy duty, can be used with EPS030 or EPS2106-2

Calibrators

- **CAL150**
- **CAL200**

Printer

- **PRN003** USB Serial Printer

SoundExpert® LxT

The SoundExpert LxT sound level meter provides targeted measurement of environmental noise, and is sold in two base models:

- **LXT1-SE-FF: SoundExpert LxT with free-field microphone (377B02)**
- **LXT1-SE-RI: SoundExpert LxT with random microphone (377C20).**

Hardware Features

The hardware features for the SoundExpert[®] LxT are the same as those for the SoundTrack LxT.[®] Additionally, the following accessories are included with the SoundExpert LxT:

- **PSA029 Power Supply**
- **CBL138 USB Cable**

Standard Features

The SoundExpert LxT is delivered with the standard features listed below.

- **LXT-LOG:** Automatic data logging with intervals from 1 second to 24 hours
- **LXT-ENV:** Measurement History Environmental Data Logging
- **LXT-CN:** Community Noise
- **LXT-OB3:** Real-time 1/1 & 1/3 Octave Band Analysis

Standard Accessories

The SoundExpert LxT is delivered with the standard accessories described below.

- **CBL138** USB Cable
- **PSA029** Universal AC Power Adaptor
- One of the following preamplifier/microphone combinations:
 - **PRMLXT1** preamplifier with a **377B02** microphone
 - **PRMLXT1L** preamplifier with a **377B02** microphone
 - **PRMLXT1** preamplifier with a **377C20** microphone
 - **PRMLXT2L** preamplifier with a **375C20** microphone.
- **SWW-SLM-UTILG4** SLM Utility-G4 software
- **SWW-SLM-UTILG3** SLM Utility-G3 software
- **WS001** Windscreen, 3 1/2 in. diameter
- Alkaline Batteries: 4-AA

- Lanyard

Optional Accessories

Equivalent Electrical Impedance Adaptor

An equivalent electrical impedance adaptor can be used in place of the microphone when a measurement is being made electrically. The adaptor is simply a series capacitor with the same capacitance as the microphone it is replacing. The following adaptors are available:

- **ADP090** 12pF adaptor for 1/2 in., 12 pF microphone (377B02)

Cables

Direct Input Cable or Adaptor

- **EXCXXX** Microphone extension cable, where XXX is the length in feet (XXX = 010, 020, 050, 066, 100 and 200 available)
- **CBL139** AC/DC Output Cable

Power Supplies

- **PSA031** 12 Volt DC to USB Power Adaptor
- **BAT015** External battery powering device for the SoundExpert[®] LxT, holding 4 or 8 D-sized alkaline 1.5 volt batteries to extend run time

Software

- **SWW-BLAZE-LXT** Blaze[®]
- **SWW-DNA +SWW-DNA-LXT**[®]

Other

- **377C20** 1/2" random incidence pre-polarized microphone, 50 mV/Pa, providing performance conforming to Class 1 sound level meter standards
- **LXT-CCS** Storage Case

Environmental Protection

- **EPS042** LxT1-SE-XX +BAT015 in small hard-shell carrying case

- **EPS2106/8-2** Environmental Shroud for outdoor microphone protection
- **EPS030-LXT** Environmental Case with one lead acid battery to be used with an external microphone tripod (the tripod is not included)

Tripods

- **TRP001** Instrument/Camera Tripod with ADP032 1/2 inch microphone clip. Use with EPS2108-2

Calibrators

- **CAL200**
- **CER-LXT1** LxT calibration with report
- **CER-MIC** Microphone calibration

Overview

This chapter provides an overview of the SoundTrack LxT[®] sound level meter, including the following sections:

- LxT Components
- Summary of Displays and Icons
- Navigating and Selecting
- Basic Run Functions
- Tab and Setting Displays

LxT Components



FIGURE 2-1 The LxT

The standard LxT shown in FIGURE 2-1 includes the following:

- 1/2 in. diameter condenser microphone
- Backlit graphic 160 x 240 pixel LCD display
- 13-key soft rubber backlit keypad
- AC/DC output, control, USB, and external power connectors (shown in FIGURE 2-2)
- True “hand held” instrument with “sure grip” pads

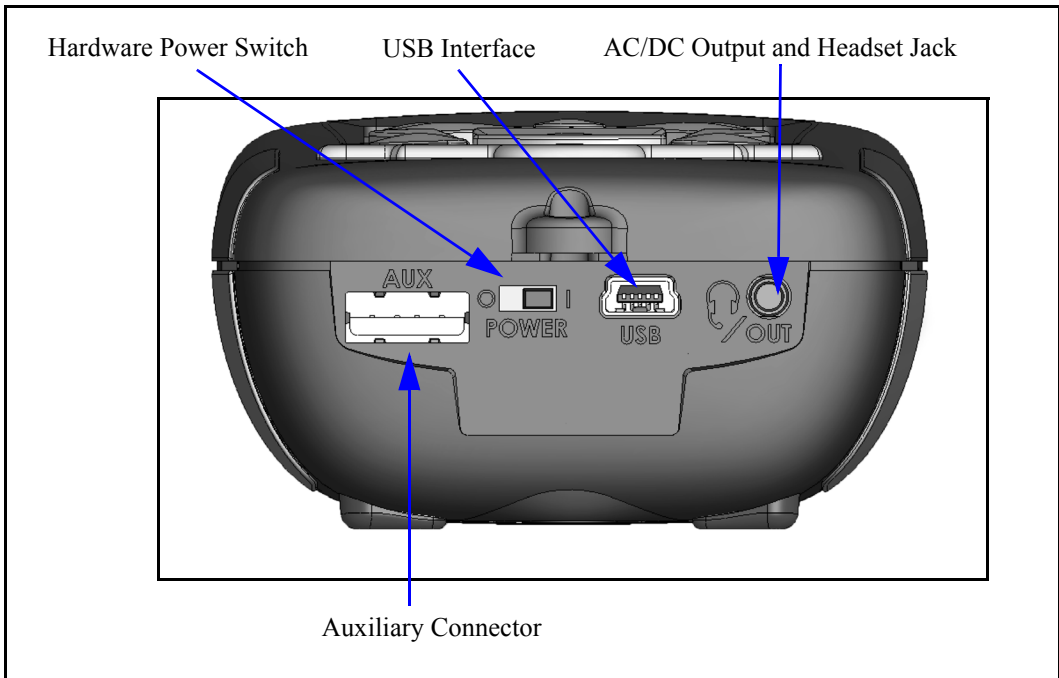



FIGURE 2-2 LxT Bottom View

DO NOT use the hardware power switch to turn the LxT OFF. This may cause data to be lost. Press the  (ON/OFF) key, then the Off soft key to turn the LxT off.

- **Hardware Power Switch:** When set to “O”, the hardware power switch completely powers down the LxT for storage. Set the switch to “I” for instrument operation.
- **USB Interface:** The USB 2.0 full-speed peripheral port is used to control LxTs from PCs and transfer data to PCs using a CBL138 or other USB cables under 5 m in length. The LxT can also be powered via USB interfaces using PSA029 external power supplies.

- **AC/DC Output and Headset Jack:** This jack is used to output analog AC and DC signals or to connect to headsets for recording and playback of voice records
- **Auxiliary USB Connector:** The auxiliary USB connector allows attaching USB storage devices.

Display

The LxT has a 160 x 240 graphic, liquid crystal display that is backlit to provide comfortable viewing in most ambient light situations. Controls are provided for contrast and backlight adjustments.

When the LxT is first turned on, a display similar to FIGURE 2-3 is shown.

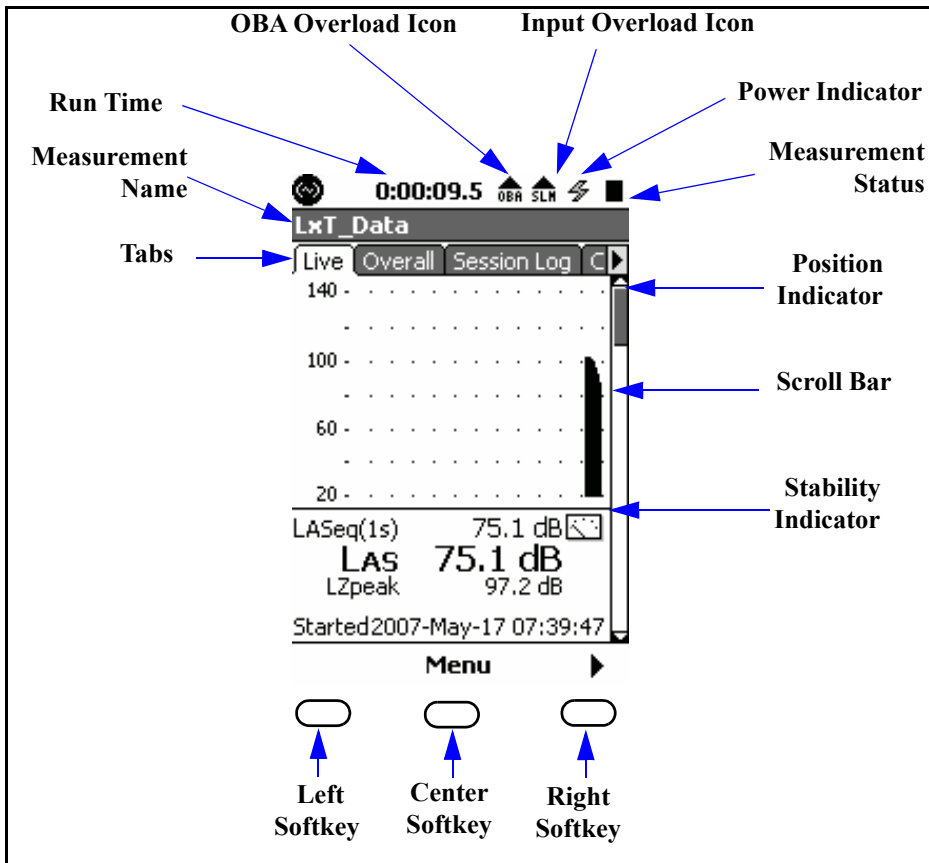

FIGURE 2-3 Data Display Screen

Keypad

The LxT has a 13 button keypad. This section describes the buttons on the keypad.

Softkeys

The three buttons just beneath the display, on the body of the LxT, are called Softkeys, as shown in Figure 2-3. Above each Softkey, on the bottom of the display, is an icon or label indicating the action that takes place when the key is pressed. Softkeys are so named because the action associated with the key can change.

Hardkeys

The ten remaining keys below the Softkeys are shown in FIGURE 2-4 and are described in TABLE 2-1.

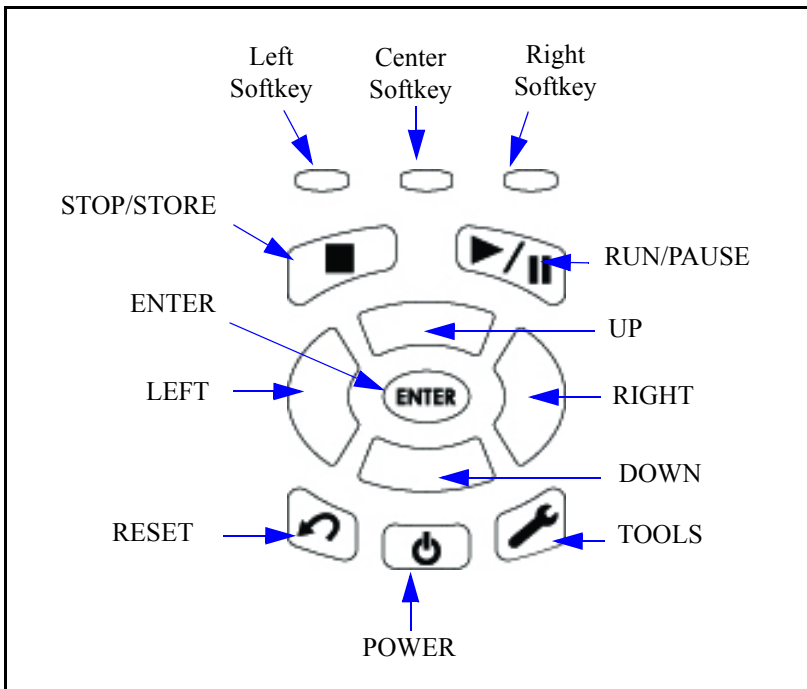

FIGURE 2-4 LxT Keys







	<p>Use the Power, or ON/OFF button to turn the LxT on and off. The hardware power switch on the base of the unit must be in the “ ” position.</p>
	<p>Use the Navigation buttons Up, Down, Left and Right to move to areas on the display, to make selections from multiple options, or to enter alphanumeric characters into data fields.</p>
	<p>Use the Enter button to select data, options, or displays or to enter alphanumeric characters into data fields.</p>
	<p>Use the Run/Pause button to initiate and pause measurements, and to continue paused measurements.</p>
	<p>Use the Stop/Store button to stop measurements and to store measurements when measurements are stopped.</p>
	<p>Use the Reset button to reset measurements.</p>
	<p>Use the Tools button to specify settings such as date and time, managing power options and setting personal preferences (i.e. language, decimal and date formats, etc.).</p>

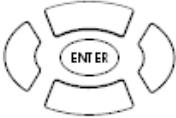

TABLE 2-1 Keypad Hardkeys

Summary of Displays and Icons

Tabs

Data on the LxT is presented in a tabbed format. Move between tabs by using the right and left Softkeys.

Pages

Tabs are divided into pages that logically group the data together (i.e., 1/3 Octave data on the **Live** tab). Navigate up or down to different pages by using the  (Up) and  (Down) keys.

Scroll Bar and Position Indicator

The scroll bar represents the entire tab, and the position indicator shows the relative position of the page you are viewing. The position indicator in FIGURE 2-3 shows that the first page on the **Live** tab is being viewed.

Power Indicator

The icon indicates whether the LxT is being powered by batteries (battery level is also indicated), or by an external power source.

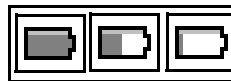

Measurement Filename

The name of the data file, or the measurement filename, is configurable as described on page 3.

Stability Indicator

For certain measurement modes and for calibration, an indication of the stability of the measured signal is presented by the following icon.



Run Time

This is the amount of time the measurement has been running.

Input Overload Icon

When signals from the preamplifier exceed the calibrated input range of the LxT, the Input Overload icon appears.

While the overload is present, the icon flashes. When the overload is removed, the icon disappears from the display.

If a measurement is running and an overload occurs, the icon shown below flashes during overloads.

When the overload has been removed, the icon is still present (not flashing) to indicate that overloads have occurred during the measurement. Resets clears the icon from the display.



Under Range Icon

When signals from the preamplifier drop below levels that can be accurately measured, an under range condition exists. When this happens the Under Range icon appears.

As long as the under range condition exists, the icon flashes. When the measured level no longer produces an under range condition, the icon is removed from the display.

When a measured level is in an under range condition, its displayed level appears in gray rather than black.



OBA Overload Icon

If inputs to the Octave Band Analyzer (optional firmware LXT-OBA required) become overloaded, the icon shown below appears to indicate overloads.

This icon operates similar to the Input Overload Icon shown in the above section “Input Overload Icon.”



Measurement Status

Reset Icon

The Reset icon indicates that a measurement is in a “reset” state.



Run Pending Icon

The Run Pending icon appears when the  (RUN/PAUSE) key is pressed and the LxT is waiting for filters and detector initialization to complete. The LxT automatically

starts the run after the initialization has completed (less than 10 seconds).



Run Icon

The Run icon is animated, moving from left to right to indicate that a measurements is in progress.



Pause Icon

The Pause icon indicates that the current measurement has been paused.



Stop Icon

The Stop icon is displayed when a measurement has been stopped.



Store Icon

The Store icon indicates that the current measurement has been stored.



Navigating and Selecting

To navigate between tabs on the display, press the right or left Softkeys. To navigate within tabs, use the \langle and \rangle keys for moving horizontally on screens. This includes moving the highlight from one property to the next.

The \lrcorner and \ulcorner keys are used for moving vertically on screens. This includes moving the highlight from one property to the next and to move to previous or subsequent tab pages.



These keys are also used for character entry by navigating through lists of characters in text boxes.

The ENTER key is typically used for completing selections, completing actions, or accepting values.

Basic Run Functions

The basic measurement run functions are as follows:

- Running
- Pausing
- Stopping
- Storing

The  (RUN/PAUSE) key initiates a run. If a measurement is running, this key pauses the run. It does not end the run; to end the measurement run, press the  (STOP/STORE) key. Pressing the  (RUN/PAUSE) key when the unit is PAUSED continues the run. This key is only active on a Data View screen.

Pressing the  (RUN/PAUSE) key when the unit is in STOP mode continues the previous run.

The  (STOP/STORE) key ends a run. Pressing the key a second time stores the data in a file. This key is only active on a Data View screen.

Tab and Setting Displays

The LxT features and functions are organized into four different types of displays.

- **Data Display tabs:** used to display measured data.
- **Measurement Settings tabs:** used to set the parameters for a measurement.
- **Control Panel (Tools) Properties:** used to set user preferences, to set non-measurement related parameters, and to implement calibration.
- **Power Control Page:** used to check battery power, control the contrast and backlight of the display and other features.

Data Display Tabs

When the  (ON/OFF) key is pressed to turn on the LxT, the Data Display tabs appear.

Measurement Settings Tabs

Opening

From the Data Display tabs, pressing the Center Softkey labeled **Menu** brings up the menu shown in FIGURE 2-5.

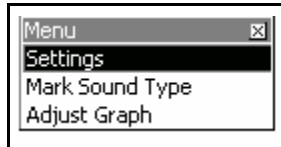



FIGURE 2-5 Menu

Select **Settings** and press **ENTER** to open the Settings tabs.

Closing

Press the Center Softkey to return the Data Display tabs.

Control Panel (Tools) Properties

The Control Panel is accessed by pressing the  (TOOLS) key at the lower right of the LxT front panel. To exit from the Control Panel and return to the Data Display tabs, press the Center Softkey labeled **Close**.

Power Control Page

The Power Control Page is opened by pressing the  (ON / OFF) key while on Data View tabs. To exit from the Power Control Page, press the Center Softkey labeled **Close**.

Data Display Tabs

For a more detailed description of the Data Display tabs and their associated pages, see Chapter 5 in the section entitled “Basic Data Display” on page 5-1.

The Data Display tabs include the following:

- **Live:** Data is continuously displayed on this tab whether there is a measurement in progress or not.
- **Overall:** The data displayed on this tab represents data measured and averaged beginning from the time the measurement was started by pressing the Run key until the elapsed time indicated above the display. If the Pause or Stop key is pressed, the elapsed time is stopped. However, pressing the Run key continues the overall measurement, as shown by the elapsed time restarting from the time when it had previously been paused or stopped.

- **Session Log:** The Session Log is a record of data accumulation actions. A time-stamped record is made for every Run, Pause, Stop or Voice Message action.
- **Current (optional)** used in conjunction with Measurement History. Similar to the Overall tab except that data is based on the most recent run instead of the first run of the measurement.
- **Measurement History (optional):** This tab displays current data measurement times or stops using the Time History measurement feature.
- **Time History (optional):** This tab displays data measured using the Time History measurement feature.

Measurement Settings Tabs

The screen is not wide enough to show all thirteen setup tabs at the same time. Use the Right and Left Softkeys to navigate between tabs and bring them within view.

For a more detailed description of the Measurement Settings tabs and their associated pages, see Chapter 4 in the section entitled “Basic Measurement Setup” on page 4-1.

The Measurement Settings tabs allow for specific settings and include the following:

- **General:** used to create a file name and a measurement description.
- **SLM:** used to setup the parameters for the measurement of sound levels.
- **OBA (optional):** used to setup the real-time octave band frequency analysis.
- **Dosimeter 1:** used to setup the parameters for the measurement of sound exposure and noise dose.
- **Dosimeter 2:** used to setup the parameters for the measurement of sound exposure and noise dose.
- **Ln:** used to define the parameters for the measurement of Ln statistics.
- **Control:** used to setup the mode of measurement timing.
- **Time History (optional):** Permits the automatic logging of a specified number of parameters as a function of time.
- **Triggers:** used to setup the triggers which define noise exceedance events.

Data Explorer

For a detailed description of Data Explorer, see Chapter 11 in the section entitled “Data Explorer” on page 11-1.

The Data Explorer is used to examine data that has been stored following previous measurements. It is also used to manage stored measurements, such as rename or delete files.

System Properties

For a detailed description of System Properties, see Chapter 12 in the section entitled “System Properties” on page 12-1.

System Properties tabs are used for general instrument bookkeeping. Functions such as setting the instrument date and time, display contrast adjustment, date format, etc. are located here. These are single page tabs.

The System Property tabs: are as follows:

- **Device:** Enter instrument identification.
- **Time:** Set the date and time.
- **Power:** Set controls that affect power consumption.
- **Preferences:** Set a variety of system parameters such as microphone correction, auto-store, jack function, reset prompting, takt maximal and USB port.
- **Localization:** Set regional characteristics such as language, decimal symbol, data format and units.

Lock

For a detailed description of the Lock feature, see Chapter 13 in the section entitled “Lock/Unlock the LxT” on page 13-1.

Lock permits the LxT to be configured such that certain keys are locked to prevent unauthorized use or tampering.

Calibrate

For a detailed description of the calibration procedure, see Chapter 7 in the section entitled “Calibration” on page 7-1.

Calibrate is used to verify and adjust the calibration of the LxT prior to a measurement.

Voice Recorder

For a detailed description of the voice recording feature, see Chapter 8 in the section entitled “Voice Recording” on page 8-1.

A method to allow voice annotation of the data is described in Chapter 8 in the section entitled “Voice Recording” on page 8-1.

About

For a detailed description of the About tabs, see Chapter 14 in the section entitled “About” on page 14-1.

The About tabs provide the user with information specific to this instrument, such as serial number, options, etc.

The About tabs include the following:

- **About:** shows information such as serial number and firmware revision.
- **Standards:** lists the standards that the LxT meets.
- **Options:** shows the options that are available in this instrument.
- **User:** allows user entered instrument identification.

Preparing for First Use

This chapter outlines the steps to unpack the SoundTrack LxT[®] and prepare it for first use, including:

- Unpacking and Inspection
- Connecting the Microphone and Preamplifier
- Disconnecting the Preamplifier
- Powering the SoundTrack LxT

Unpacking and Inspection

Retain the packaging for safe shipment for calibration service.

Your LxT has been shipped in protective packaging. Please verify that the package contains the items listed below. Report any damage or shortage immediately to PCB[®] Piezotronics, Inc. at 888 258-3222 (U.S. toll free) or (716) 926-8243.

- LxT
- PRMLxT Microphone Preamplifier
- Microphone
- Lanyard
- WS001 3 1/2" Windscreen
- 4 - AA Alkaline Batteries
- SLM Utility-G3 software
- SLM Utility-G4 software

Record Serial Numbers of LxT and Components

If you have not already done so, please record the purchase date, model and serial number for your instrument, preamplifier and microphone in the spaces provided at the beginning of this manual. You find the instrument model and serial numbers printed on the label on the back panel of the instrument.

The microphone model and serial numbers are engraved on the outside of the microphone, as shown in FIGURE 3-1. The preamplifier model and serial numbers are engraved on the preamplifier body as shown in FIGURE 3-2.



FIGURE 3-1 Microphone

You may be asked to provide this information during any future communications with PCB® Piezotronics, Inc.

Connecting the Microphone and Preamplifier

Caution: Take care when handling the preamplifier, as the gold pin is sensitive to electrostatic discharge (ESD).

Carefully place the bottom end of the microphone over the top end of the preamplifier and gently screw the assembly together. The microphone body seats smoothly against the preamplifier body. **DO NOT** use excessive force.

When removing the microphone, turn while gripping the microphone body, not the grid cap.



FIGURE 3-2 Microphone-Preamplifier

Connecting the Preamp to the LxT

The connectors are keyed for correct alignment.

Caution: Do not attempt to unscrew the collar/ring at the top of the LxT body.

Insert the preamplifier into the mating connector on the LxT and rotate the preamplifier until the keyways line up. Press the assemblies together until a small click is heard.

If the LxT is powered when the preamplifier is inserted, a message similar to the one in FIGURE 3-3 appears for several seconds.

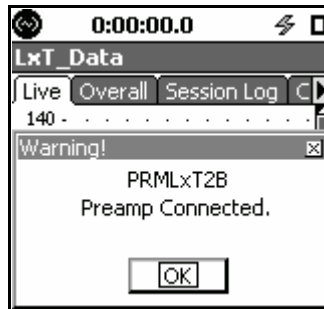



FIGURE 3-3 Preamplifier Connected

Press  (ENTER) to close the message.

Disconnecting the Preamplifier from the LxT

When transporting the LxT, it is recommended that the preamplifier be detached and placed in a secure location in the carrying case.

On the front of the LxT, just below the preamplifier connector, is a small button. Press and hold this button while pulling the microphone/preamplifier assembly out of the LxT, as shown in Figure 3-4.

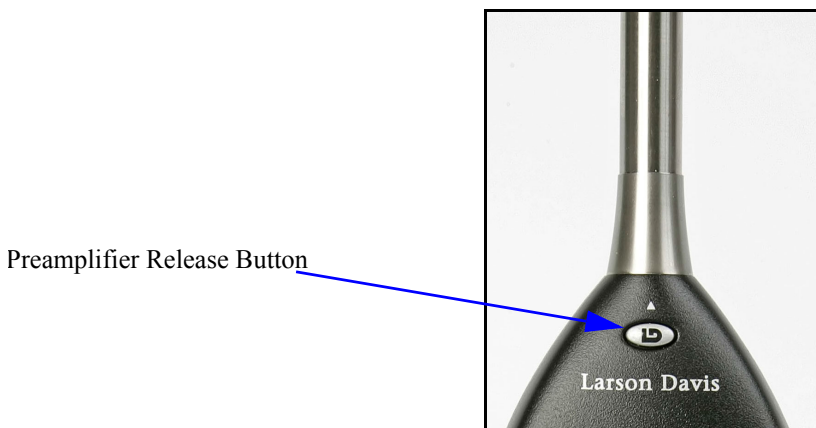

FIGURE 3-4 Preamplifier Release Button

Powering the SoundTrack LxT®

The following sections provide power information for the LxT, including the following:

- **Important Notice Regarding Proper Shutdown**
- **Batteries**
- **Hardware Power Switch**
- **USB Power**
- **External Power Supply PSA029**
- **Power Settings**

Important Notice Regarding Proper Shutdown

Improperly turning off the power to the LxT may damage the instrument. To properly shut off power, use the on/off button on the front of the meter.

If the LxT is being powered externally via a USB cable, do not unplug the cable without ensuring that the batteries in the instrument have adequate charge or properly powering down the LxT first.

The LxT should also be properly shut off prior to changing batteries.

Batteries

Do not use 3.8 V Lithium batteries; they will blow the fuse.

The LxT is compatible with AA alkaline, nickel-metal hydride (NiMH) batteries and 1.5 volt Lithium batteries.

NOTICE:

- NiMH batteries cannot be charged in the LxT. Do not mix alkaline and NiMH batteries in the LxT.
- Do not mix batteries from different manufacturers.
- Replace all four batteries when installing fresh cells.
- NiMH batteries may not be used in areas requiring Intrinsic Safety Approval.

Battery Status

Battery voltage and estimated run time are displayed on the Power Control page and the last page of the **Live** tab. When the LxT is powered by batteries, one of the icons shown in FIGURE 3-5 is shown on the status bar at the top of the screen. The icon shows the state of the battery charge as a full battery when the batteries are fresh, decaying to an empty battery near the end of the battery life. The battery voltage and the battery icon directly reflect the remaining estimated run time as displayed by the instrument.



FIGURE 3-5 Battery Status Icons

When the battery voltage becomes critically low, the empty battery icon begins to flash, indicating that the LxT is about to shut down. When the LxT shuts down, it stops running, saving all data and the instrument state, and then turns off. When the unit is powered on again, either with fresh batteries or an external power supply, the unit returns to the state it was in when it shut down.

Hardware Power Switch

DO NOT use the hardware power switch to turn the LxT OFF. This may cause data to be lost. Press the  key, then the Off soft key to turn the LxT off.

It is recommended that the batteries be removed from the instrument if it will not be used for a month or longer as the batteries may self-discharge and leak, damaging the instrument.

The Hardware Power Switch on the bottom of the LxT, shown in Figure 2-2 disconnects the batteries from the LxT hardware, including the real time clock. This prevents battery drain when the LxT is not in use for an extended period of time (> 2 weeks). If the Hardware Power Switch is in the “O” position, the batteries are disconnected.

After installing batteries be sure to move the switch to the “I” position. This applies power to all of the LxT hardware.

The Hardware Power Switch should not be used to turn the LxT on and off. If the Hardware Power Switch is used to turn the LxT off, data may be lost and Flash corruption may result.

USB Power

The LxT cannot be operated under USB power if the internal batteries are discharged (flat). You can run solely on USB power if you remove the depleted batteries. However, if operated on external power only, with no batteries installed, an interruption of power to the LxT, for any reason, may result in instrument malfunction.

The LxT can be powered from batteries or, if available, from the USB host portion of your computer.

The LxT must run on batteries until allowed by the host to run on USB or external power. If the batteries cannot provide sufficient power, the LxT does not power on, even with USB external power. If batteries are installed in the LxT, ensure that they are good so that the LxT can power on.

If the LxT has discharged batteries installed, the batteries should be removed or replaced with fresh batteries in order for the LxT to be USB powered.

To avoid memory corruption when using USB Power or flash drives, follow these precautions:

- **Always shut down the LxT completely before unplugging USB power connections.**
- **Do not unplug USB drives from the USB port on the LxT while the drive is being copied, or if the LxT is within Data Explorer mode.**

External Power Supply PSA029

In addition to running on batteries, or USB power, the LxT can be powered from a PSA029 power supply. When

external power is being supplied, the Battery icon is replaced with the icon shown in FIGURE 3-6.



FIGURE 3-6 External Power Icon

The LxT cannot be operated with an external power supply if the internal batteries are discharged (flat). You can run solely on external power if you remove the depleted batteries. However, if operated on external power only, with no batteries installed, an interruption of power to the LxT, for any reason, may result in instrument malfunction.

The PSA029 is designed to work on power systems worldwide.

The LxT must run on batteries until allowed by the host to run on external power. If the batteries cannot provide sufficient power, the LxT does not power on, even with external power. If batteries are installed in the LxT, ensure that they are good so that the LxT can power on.

Power Settings

If the LxT is ON, pressing the  (ON/OFF) key brings up the Power Control Page, as shown in FIGURE 3-7.

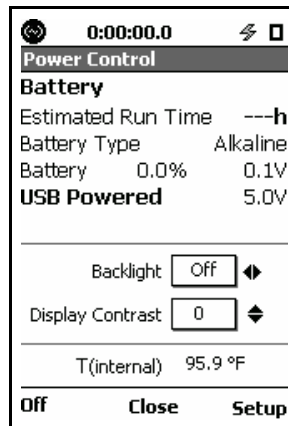









FIGURE 3-7 Power Control Page

The first section of this page shows the estimated battery run time (calculated using the voltage of the installed batteries), battery voltage, and the USB power voltage.

The Backlight can also be adjusted from the Power Page as described in the section Power'on page 12-4.

The Center Softkey provides an exit, escape or cancel function as well as the function displayed above it on the display.

The backlight mode and display contrast are adjusted using the , ,  and  keys. There are three options for **Backlight: Off, Dim, and Bright**, which are adjusted using the  and  keys. The Display Contrast has a range of -9 to 9, which is adjusted using the  and  keys.

The bottom of the **Power Control** page displays the LxT temperature that is used to automatically adjust the contrast of the display to compensate for temperature changes.

Pressing the Center Softkey, labeled **Close**, closes the **Power Control** page.

Basic Measurement Setup

This chapter describes how to setup the LxT to perform basic sound level measurements, including the following:



- Leq, Lmax, Lmin corresponding to user-selected values of frequency weighting and detector
- Lpeak and Lpeak(max) corresponding to a user-selected value of frequency weighting
- 1/1 and/or 1/3 Octave real-time spectra (LxT-OB3 required)
- Six values of Ln based on six user-selected values of the parameter n
- Count of the number of times the levels (RMS and Peak) exceeded user-selected threshold values
- Sound exposure and sound exposure level data

The LxT can measure many additional sound parameters simultaneously with these basic sound measurements, as described in subsequent chapters.

Measurement Settings Tabs

Accessing the Measurement Settings Tabs

The parameters defining measurements are set from the Measurement Settings tabs.

To access these tabs, press the Center Softkey labeled **Menu**, press the  key to select **Settings**, and press the  (ENTER) key. The Measurement Settings tab most appropriate for the data now appears.

Settings In Use Message

If the LxT is not already connected to a computer running Blaze, SLM Utility-G3, or G4 software, ignore this section.

If the Blaze, SLM Utility-G3, or G4 software is already connected to the LxT when an attempt is made to access the Measurement Settings Screen, the display shown in FIGURE 4-1 "Settings In Use By PC Message" appears.



FIGURE 4-1 Settings In Use By PC Message

This message indicates that setup changes made with SLM Utility-G3 or G4 software in this session will be lost if you continue.

To continue and access the Measurement Settings tabs, highlight **Yes** and press **ENTER**. To cancel the attempt to access the Measurement Settings Screen, highlight **No** and press **ENTER**.

General Tab

Figure 4-2 shows the **General** tab.

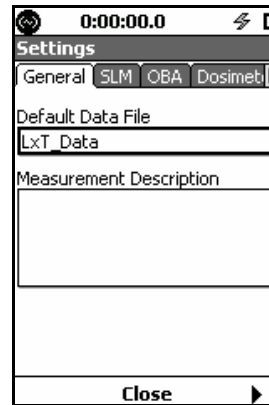

FIGURE 4-2 General Tab

The SLM Utility-G3 or G4 software can be used to easily enter both the file name and the measurement description.

The **General** Tab is used to enter file names and measurement descriptions for the measurements being defined. Upon opening, the Default File Name “LxT_Data” may appear in the file name field.

To enter new file names, select the Default File Name text box and press **ENTER**. Use the **{**, **}**, **⌋** and **⌌** keys to enter new names and press **ENTER**.

Figure 4-2 shows the **SLM** tab.

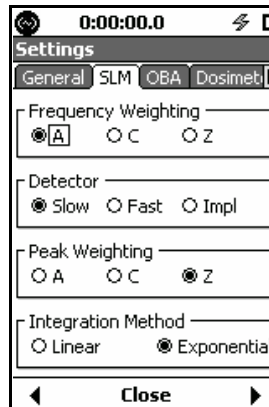

FIGURE 4-3 SLM Tab

To modify settings on the **SLM** tab, navigate to either **Frequency Weighting**, **Detector**, **Peak Weighting**, or **Integration Method** page and press **ENTER**.

Frequency Weighting

A, C and Z frequency weightings are provided for the RMS and peak detectors. These are selected separately.

Integration Method

Two Integration methods are available: **Linear** and **Exponential**.

Exponential Integration

Exponential integration would typically be selected to provide compatibility with older analog instruments in which measurements are exponential time weighted signals. Exponential detectors tend to hide small events in the long decay of loud impulsive events.

Linear Integration

Linear integration utilizes sampled sound pressure levels to compute RMS levels directly, without an intermediate time weighting.

Octave Band Analyzer Tab (Optional)

The default values for these parameters are as shown in FIGURE 4-4.

This tab only appears when the LxT has the optional LxT-OB1 or LxT-OB3 firmware enabled.

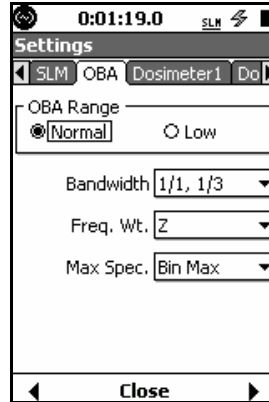

FIGURE 4-4 OBA Tab

OBA Parameter Selection

The OBA parameters are selected as shown in FIGURE 4-5.

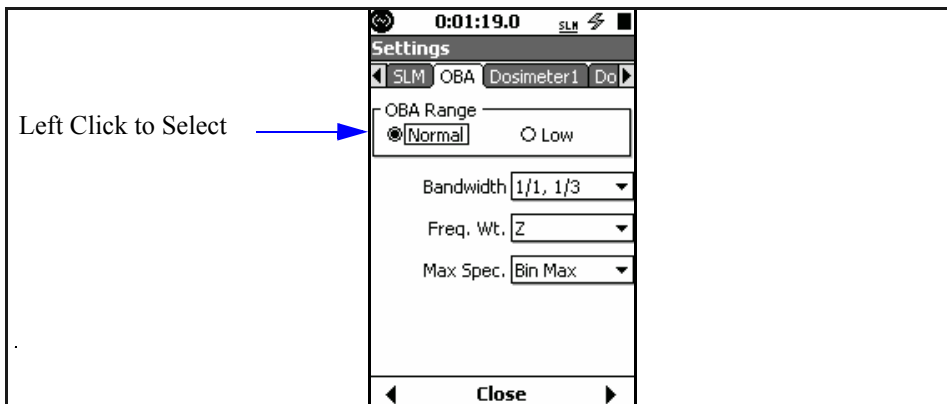

FIGURE 4-5 OBA Parameter Selection

OBA Range Setting

In the Low range, the full scale level is reduced by 30 dB on the display. The default display ranges are as follows:

- **Normal Range:** 20 to 140 dB
- **Low Range:** -10 to 110 dB

Graph scaling range can be modified by the user, as described in “Graph Scale Adjustment” on page 5-2.

OBA Frequency Weighting

The user can select that the 1/1 and/or 1/3 Octave frequency analysis modules process data from the A, C or Z weighting filters.

OBA Max Spectrum Setting

Two methods can be used to define the maximum spectrum:

- **At Lmax:** using this method, the maximum values for each frequency band are those that are being measured at the instant the overall sound pressure level reached its maximum value during the measurement period.
- **Bin Max:** using this method, the level measured for each frequency band is the maximum measured during the measurement period. Since the maximum levels for the different frequency bands may have occurred at different times, the ensemble of frequency band maximum levels may represent a spectrum that never existed at any single instant during the measurement.

Dosimeter 1 and 2 Tabs

Figure 4-6 shows the **Dosimeter 1** tab.

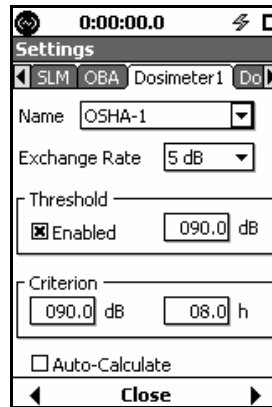

FIGURE 4-6 Dosimeter 1

The **Dosimeter 1** and **Dosimeter 2** tabs are provided to permit the evaluation of two independent noise dose data sets. Other than being on separate tabs, they are identical.

Predefined Setups

In most cases, measurements of this type are setup to conform to specific standards. The LxT permits the user to create such setups in a single step by simply selecting the applicable standard. The standards addressed by the LxT and the corresponding parameters are as shown in Table 4-1 "Predefined Noise Dosimeter Setups".

Standard	Exchange Rate	Threshold	Criterion	
			Level	Hours
OSHA-1	5	90	90	8
OSHA-2	5	80	90	8
ACGIH	3	80	85	8
NIOSH	3	80	85	8
IEC	3	Not Enabled	85	8

Table 4-1 Predefined Noise Dosimeter Setups

The **Name** field is already highlighted when the Dosimeter View is opened. If this has been changed, use the  key to move the highlight back to the **Name** field.

The names of the predefined setups can be accessed from the **Name** field at the top of the display. Press  to show a list of predefined setups by name as shown in FIGURE 4-7 "Predefined Dose Setups"

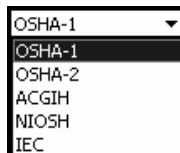

FIGURE 4-7 Predefined Dose Setups

Parameters Individually Defined

The **Dosimeter** tab contains two fields (**Name** and **Exchange Rate**) and two sections (**Threshold** and **Criterion**).







Name Field

If a predefined setup has been selected and any of the preset parameters are modified, the user should consider changing the name of the setup.

The **Name** field is optional, although many users enter text associated with the measurement to be performed, such as specific company Dose standards ("My Dose") or names of standards not in the list.

Threshold and Criterion

When setting the **Threshold** value, the **Enabled** check box must be checked before data can be entered into the numeric field. Use the **Left Softkey** to highlight the box and press .

To set these parameters, after highlighting the appropriate section, press , use the , , , and  keys to enter the numeric value desired, then press .

Auto-Calculate

The **Criterion Level** and **Time** are set independently. However, **Criterion Level** and the **Time** have a linear relationship, so when Auto-Calculate is activated for either, both are automatically set to follow the applicable standard.

Ln Tab

Figure 4-8 shows the Ln tab.

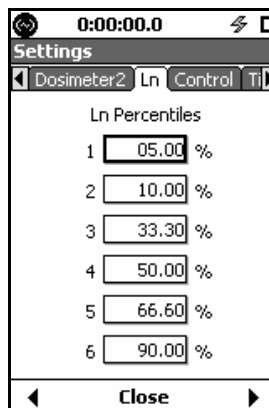

FIGURE 4-8 Ln Tab

The Ln value is the measured sound level that exceeds n% of the measurement time. For example, a value of $L_{90} = 35$ dB means that the measured sound level is above 35 dB for 90% of the measurement period. These statistical values are commonly used to describe the characteristics of non-steady sound such as environmental noise.

The LxT can calculate six different Ln values based on user-defined values of n, which can be in the range 00.01 to 99.99%.

Control Tab

The **Control** tab, shown in Figure 4-9, is used to set the Run Mode for the measurement to be performed.

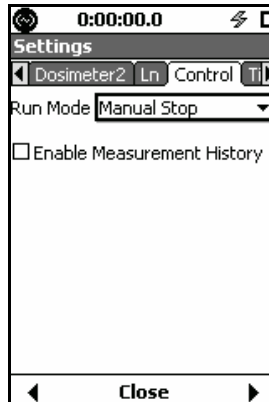











FIGURE 4-9 Control Tab

When the optional firmware LXT-ENV has been enabled, Measurement History can be enabled in the Run Control Setup.

The Run Mode on the **Control** tab can be setup for one of six modes, including the following.

- **Manual Stop:** The measurement is initiated manually by pressing the  (Run/Pause) key and is stopped by pressing the  (Stop) key.
- **Timed Stop:** The measurement is initiated manually by pressing the  key and is stopped automatically after a user-defined time period.
- **Stop When Stable:** The measurement is initiated manually by pressing the  key. The measurement stops when the measured level has remained within a user-defined range and the measurement has run for a user-defined time period.
- **Continuous:** The measurement is initiated manually by pressing the  key and is stopped by pressing the  key. Measurements are made continuously from start to stop.
- **Single Block Timer:** The measurement is initiated manually by pressing the  key and is stopped by pressing the  key. Measurements are made only during the time interval defined by the single block timer.

- **Daily Timer:** The measurement is initiated manually by pressing the  key and is stopped by pressing the  key. Measurements are made only during the separate time blocks defined by the setup.



When the **Control** tab is opened, the Run Mode field is already selected. Press  to open the Run Mode Menu, as shown in Figure 4-10.



FIGURE 4-10 Run Mode Menu

Navigate to select the desired mode and press  to make the selection. The screen then appears as one of those shown in Figure 4-11, depending upon the mode selected. For the **Timed Stop** and **Stop When Stable** modes, further information must be entered.

Manual, Timed Stop, or Stop When Stable Modes

When the run mode used is **Manual**, **Timed Stop** or **Stop When Stable**, a single measurement runs continuously from start time to end time. The selection and setting of parameters for these run modes is shown in FIGURE 4-11.

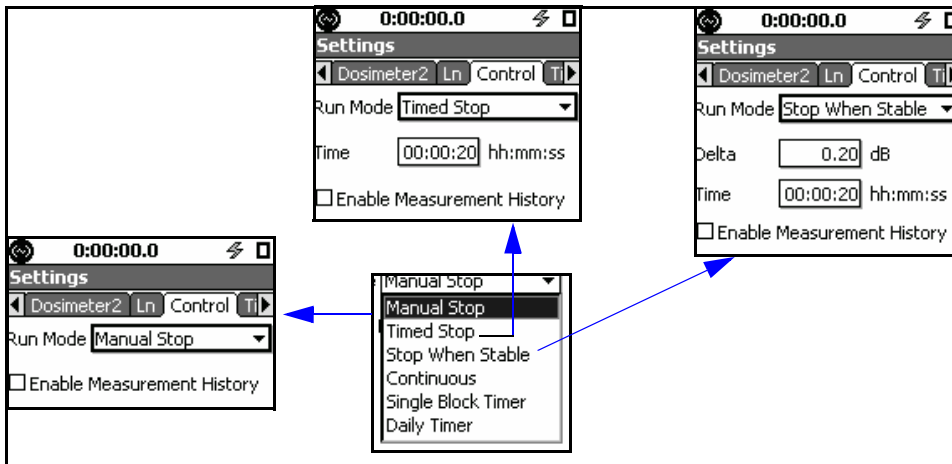

FIGURE 4-11 Setup of Manual Stop, Timed Stop, and Stop When Stable Run Modes

Entering Run Time for the Timed Stop Mode

To enter the Run Time, navigate to select the **Time** data field and press **ENTER**. You can then move left and right to different digit positions in the data field using the **←** and **→** keys, as shown in Figure 4-12.

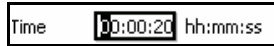

FIGURE 4-12 Entering Time in Timed Stop Run Mode

Stop When Stable Mode

The **Stop When Stable** run mode contains the data fields **Delta** and **Time**, as shown in Figure 4-13.

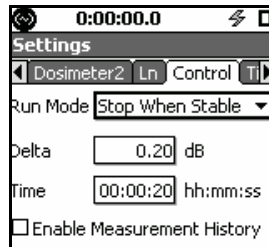

FIGURE 4-13 Stop When Stable Run Mode

Delta Level

The Delta level is the maximum one minute change in overall average level (i.e. L_{Aeq}) allowed for the measurement to be considered stable.

Time

The Time is the duration that the measurement must run before the measurement can stop.

If the time were set to 0, the measurement would run until the stability condition was met.

Once duration is set, the measurement runs for the duration specified and then continues until the stability condition is met.

Run Modes Without Measurement History

All Run Modes include check box options to enable the Measurement History feature. The descriptions presented in

the following sections are for setups without Measurement History enabled.

When Measurement History is not enabled, the measurement must be manually stored at the conclusion of the duration. Because only a single measurement exists, the data displayed on the **Overall** and **Current** tabs is identical.

Continuous

The **Continuous** run mode is similar to the **Manual Stop** mode, except that **Daily Auto-Store** can also be enabled, in which case daily measurement reports for 24-hour time periods are automatically stored. The user specifies a beginning time for such periods. This also presumes that the measurement time period encompasses at least one 24-hour time period as programmed. The parameter **Time** defines the start time for the 24-hour time period to be used for the report.

Single Block Time or Daily Timer

When the run mode is **Single Block Timer** or **Daily Timer**, the single measurement consists of data measured over different blocks of time between the start date and time and the end date and time.

The selection and setting of appropriate parameters for the **Continuous**, **Single Block Timer** and **Daily Timer** run modes is shown in FIGURE 4-14.

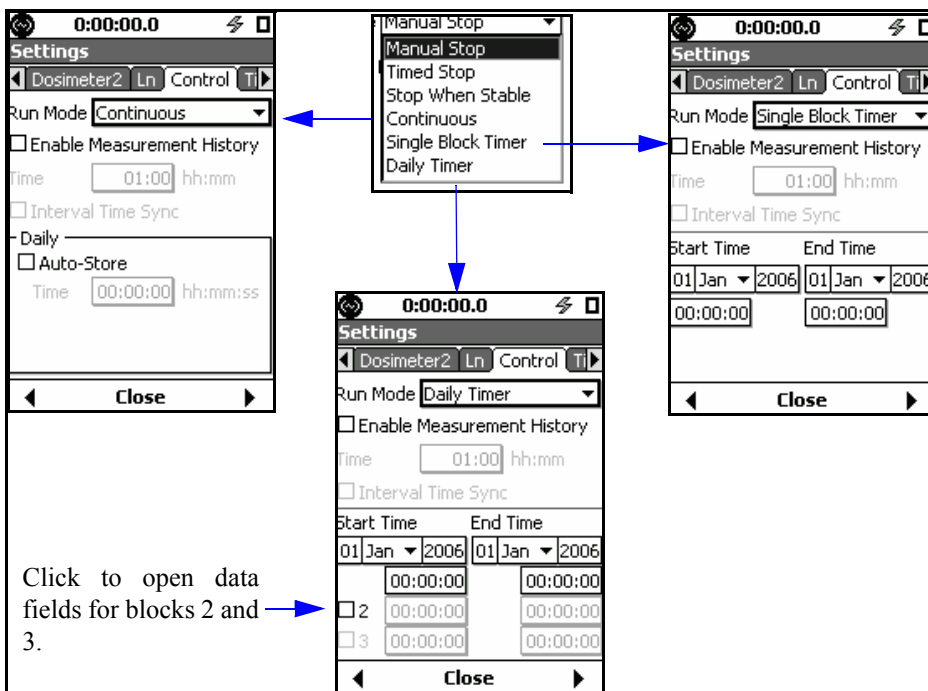

FIGURE 4-14 Setup of Continuous, Daily Timer and Single Block Time Run Modes

For each run mode option, select the corresponding data field and press the **ENTER**. To enter the desired values, press the **ENTER** again.

For the **Continuous** mode, when the **Auto-Store** checking the box in the **Daily** tab results in the following: daily measurement reports for 24-hour time periods are automatically stored, beginning at a user-specified time (assuming that the measurement time period encompasses at least one 24-hour time period as programmed).

When the option is checked, a data field opens to define the start time for the 24-hour time period to be used for the report, as shown in FIGURE 4-15.

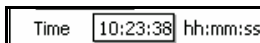

FIGURE 4-15 Auto-Store Report Start Time

Select the data field and use the navigation keys to specify the start time.

Run Mode with Measurement History

Measurement History requires that the optional firmware LXT-ENV be enabled.

To measure and store sequences of measurements using the same setup, either manually or automatically, you can use the Measurement History feature, which is described in detail in "Measurement History".

Triggers Tab

Note that the default values for these parameters are as shown in FIGURE 4-16.

FIGURE 4-16 shows the **Triggers** tab.

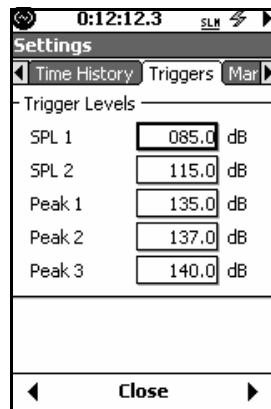

FIGURE 4-16 Triggers Tab

The **Triggers** tab is used to define trigger levels that can then be used to detect when the measured sound level (SPL or Peak) exceeds one of these trigger levels.

Day/Night

The default values for these parameters are as shown in FIGURE 4-17.

The Day/Night parameters are used in conjunction with Community Noise Measurements that require the optional firmware LXT-CN to be enabled.

Among the parameters measured and displayed as part of a basic sound level measurement are the community noise descriptors L_{DN} and L_{DEN} . The **Day/Night** tab defines the times and penalties to be used.

FIGURE 4-17 shows the Day/Night tab.

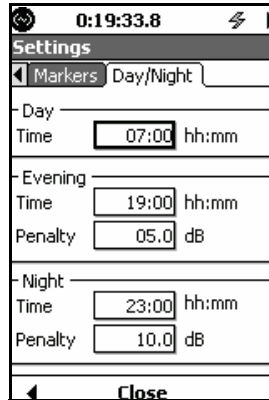

FIGURE 4-17 Day/Evening/Night Definition

L_{DN}

The day-night level L_{DN} defined by the following formula:

$$L_{dn} = 10 \log_{10} \left\{ \frac{1}{24} \left[\sum_{0000}^{0700} 10^{(L_i + 10)/10} + \sum_{0700}^{2200} 10^{L_i/10} + \sum_{2200}^{2400} 10^{(L_i + 10)/10} \right] \right\}$$

L_{DEN}

The day-evening-night level L_{DEN} is defined by the following formula:

$$L_{DEN} = 10 \lg \left(\frac{1}{24} \right) \left[12 * 10^{\frac{L_{day}}{10}} + 4 * 10^{\frac{L_{evening} + 5}{10}} + 8 * 10^{\frac{L_{night} + 10}{10}} \right]$$

In the default form, the day has twelve hours, the evening has four hours and the night has eight hours, as can be seen in the equation. The default times for these periods are as follows:

- **Day: 07.00 to 19.00**
- **Evening: 19.00 to 23.00**
- **Night: 23.00 to 07.00**

L_{day}, L_{evening} and L_{night} are A-weighted long-term average sound levels measured during the day, evening and night, respectively.

To account for the increased impact of environmental noise during the evening and night, penalties are added to the measured level; 5 dB for evening and 10 dB for night, as can be seen in the equation.

The Directive 2002/49/EC of the European Parliament and of the Council of 25 June 2002, relating to the assessment of environmental noise permits member states to shorten the evening period by one or two hours and lengthen the day and/or the night accordingly and also to choose the time for the start of the day.

To accommodate these and other possible modifications, the **Day/Night** tab permits the user to modify the times for the beginning of the Day, Evening and Night periods and the penalties to be utilized when calculating 24-hour integrated values.

CNEL

In the state of California, a commonly used community noise descriptor is Community Noise Equivalent Level (CNEL), defined by the following formula:

$$CNEL = 10 \log_{10} \left\{ \frac{1}{24} \left[\sum_{0000}^{0700} 10^{(L_i + 10)/10} + \sum_{0700}^{1900} 10^{L_i/10} + \sum_{1900}^{2200} 10^{(L_i + 5)/10} + \sum_{2200}^{2400} 10^{(L_i + 10)/10} \right] \right\}$$

This is essentially the same as the L_{DEN} using default values, with the exception that the evening period begins at 22.00 instead of 23.00. Thus, by making this change in the L_{DEN} settings, the measured value represents CNEL.

Data Display

This chapter describes how data is displayed for basic sound level measurements.

Data Labels

The LxT sound metrics labels are designated by international standards. For many displayed values, the frequency and time weighting are indicated in the name of the metric. Example: L_{AS} is the A-weighted sound pressure level measured using the Slow detector. Sound pressure level is often referred to as SPL.

Tabbed Display

Measured data are displayed using a number of tabs arranged horizontally across the screen, as shown in Figure 5-1. Depending on the firmware options loaded in the LxT, multiple tabs appear in the Data Display, each identified by a title at the top.







FIGURE 5-1 Tabbed Display

Navigating through Tabs





Not all of the tabs can be seen at one time on the display. To see tabs on the right, use the Right Softkey beneath the display. To navigate to the left, use the Left Softkey beneath the display.

Navigating within Tabs

Each tab contains multiple pages. To navigate between pages, use the  or  keys.





The  and  keys can be used to move the cursor left and right, respectively, to select a specific filter or record, depending on the data being displayed.

Selecting Options for Settings within Tabs

By using the  and  keys or the  or  keys to move between options on tabs or pages, you can select options by highlighting them. Once the desired value or option is selected, press  (ENTER).

On some tabs, you can also select check box options by highlighting them and pressing .

Specifying Values for Settings within Tabs

Sometimes the  and  keys or the  or  keys may be used to increase or decrease the scaling or level of some settings within pages of the tabs, once the setting is selected. In these cases, once the desired value is specified, press .

Under Range Condition

When a measured level is in an under range condition, its displayed level appears in gray rather than black.

Graph Scale Adjustment

The default amplitude (dB) settings for the graphic display of sound pressure level versus time and frequency spectra (1/1 and 1/3 octave) are as indicated below:

- **Level vs. Time Graph:** 20 dB to 140 dB
- **Frequency Spectra, Normal Range:** 20 dB to 140 dB
- **Frequency Spectra, Low Range:** -10 dB to 110 dB

To change the scaling of any one of these graphs, press the Menu softkey to obtain the display shown in FIGURE 5-2.

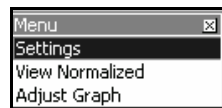

FIGURE 5-2 Menu

Select **Adjust Graph** and press **ENTER** to obtain the Adjust Graph menu shown in FIGURE 5-3

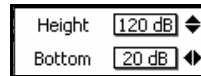

FIGURE 5-3 Adjust Graph Menu

Move the **←** and **→** keys to change the baseline level and the **⌈** or **⌋** keys to adjust the height (range between the baseline and the top of the display). The arrow icons indicate which arrow key adjusts which value. Press **ENTER** to implement the change.

Once the scaling on one or more graphic displays has changed, it remains that way until changed again or until the defaults settings are restored.

When changing range between normal and low, the scale is automatically adjusted.

Live Tab

This sections describes the pages on the **Live** tab. The **Live** tab contains the following pages:

- **Profile**
- **Digital**
- **1/1 Octave (optional with separate license)**
- **1/3 Octave (optional with separate license)**
- **Triggering**
- **Power**

Upon turning on the LxT, the **Live** tab is displayed. The measurements displayed on the **Live** tab are active, real-time measurements. The displayed values are not controlled by the **▶/⏸** (RUN/ PAUSE) key. This allows you to view the current SPL without disrupting any measured data. For example, suppose you are making a measurement and an unwanted event takes place, causing you to stop the measurement. With the measurement stopped, you can monitor the actual level on the **Live** tab to be certain that the residual effects of the unexpected event have finished before beginning a new measurement.

Profile Page

The **Profile** page presents recent graphic history of L_{eq} , using the user-selected frequency weighting, calculated for each second. The graph presents the last 120 seconds of the measurement. Figure 5-4 shows the **Profile** page.

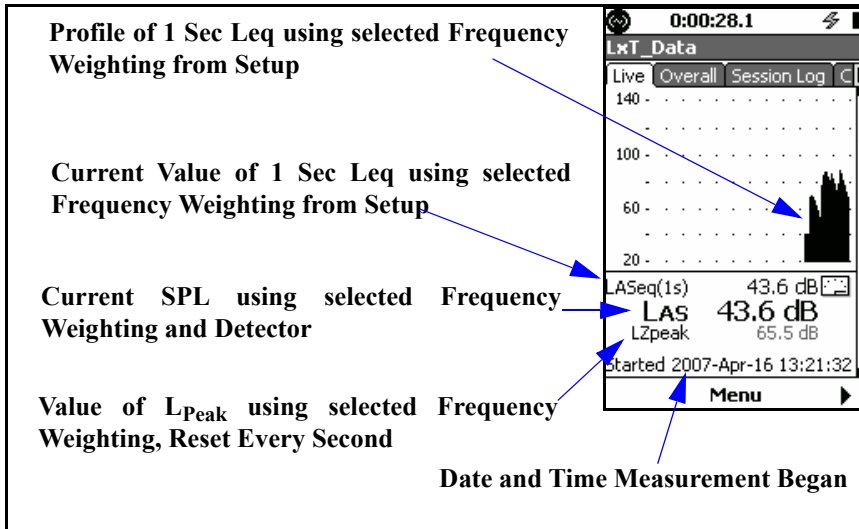

FIGURE 5-4 Live Tab, Profile Page

The time at the bottom of the page is the date and time that the measurement started.

Digital Page

The **Digital** page displays both the instantaneous sound level and the value of the user-selected SPL1 Trigger Level, as shown in Figure 5-5.

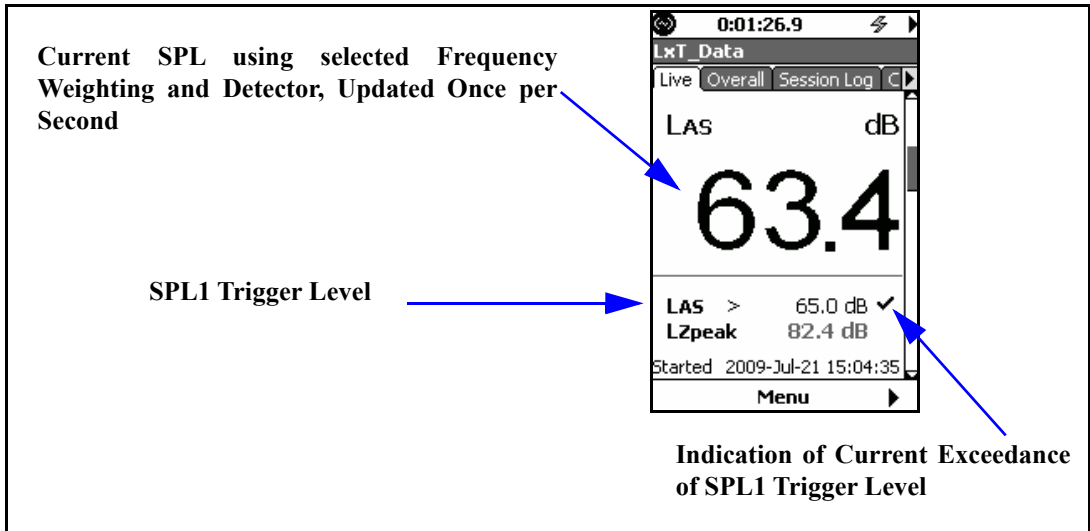

FIGURE 5-5 Live Tab, Digital Page

In addition to displaying the current value of Leq, this page displays check marks to indicate current of the SPL1 trigger level, which are user-defined, as described in page "Triggers Tab" on page 4-15.

1/1 Octave Page (Optional)

The 1/1 Octave Band Analyzer appears only when the sound level meter is loaded with the optional LxT-OB1 or LxT-OB3 firmware.

The 1/1 Octave page displays bar graphs of sound level in 1/1 octave frequency bands, as shown in Figure 5-6. The right most bar on the graph is the selected broadband SPL value (in this instance, L_{AS}).

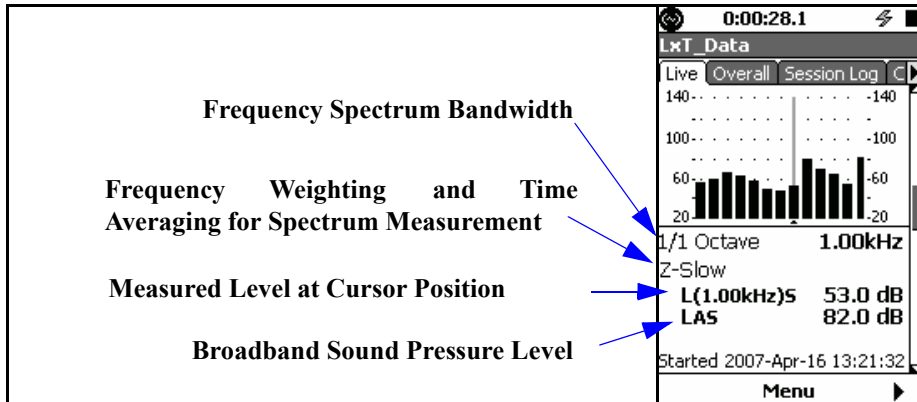

FIGURE 5-6 Live Tab, 1/1 Octave Page

The spectrum frequency weighting is selected independently from that of the sound level measurement, as described in “OBA Frequency Weighting”. The detector is the same as that of the sound level measurement.

1/3 Octave Page (Optional)

The *1/3 Octave Band Analyzer* page appears only when the sound level meter is loaded with the optional LxT-OB3 firmware.

The **1/3 Octave** Page is similar to the **1/1 Octave** Page, but the graph and data are presented for 1/3 octave filters, as shown in Figure 5-7.

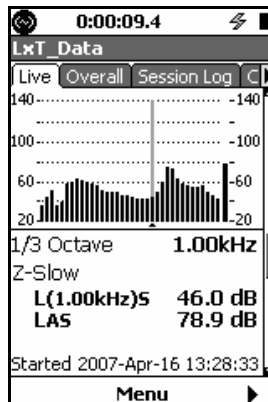

FIGURE 5-7 Live Page, 1/3 Octave Page

Triggering

For a description of the setup of these trigger values, see “Triggers Tab”.

The **Triggering** page displays the sound level and peak level with their associated trigger points, as shown in Figure 5-8. Exceedances of these trigger points are indicated by check marks appearing to the right of each. Check marks appear only as long as the measured level remains above the trigger point.

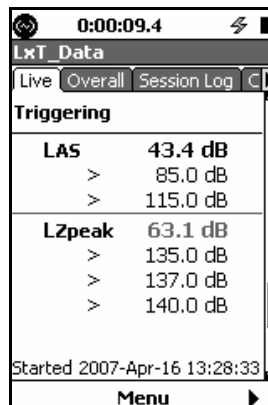

FIGURE 5-8 Live Tab, Trigger Page

Power Page

The **Power** page displays the current **Date** and **Time**, the run time for the measurement, the battery voltage, the calculated run time and the memory usage.

The **Memory** section indicates the amount of memory available as a percentage and in number of kilobytes. The number of stored data files is also indicated.

Figure 5-9 shows the **Power** page.



FIGURE 5-9 Live Tab, Power Page

Overall Tab

This section describes the pages of the **Overall** tab associated with basic sound level measurements. The **Overall** tab includes the following pages:

- **Profile**
- **Digital**
- **Leq**
- **1/1 Octave (optional with separate license)**
- **1/3 Octave (optional with separate license)**
- **Dose 1**
- **Dose 2**
- **SEL**
- **SEA**

- Percentiles
- Exceedances
- Overloads
- Community Noise
- Miscellaneous
- Memory

Profile (with Overall Leq)

Figure 5-10 shows the **Profile** page of the **Overall** tab.

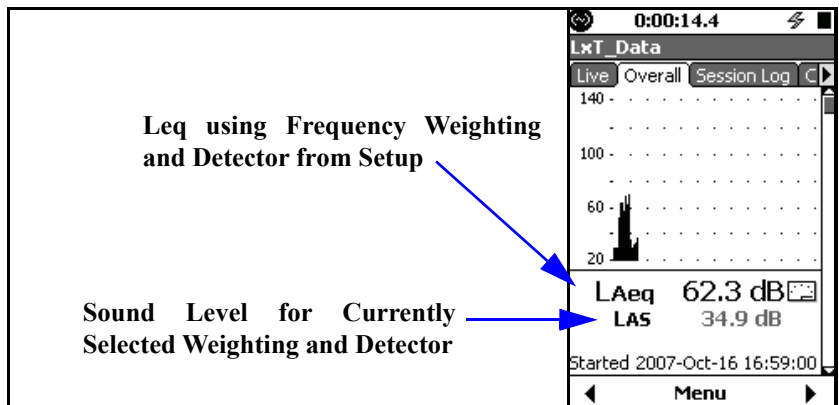

FIGURE 5-10 Overall Tab, Profile Page

Digital

Figure 5-11 shows the **Digital** page of the **Overall** tab.

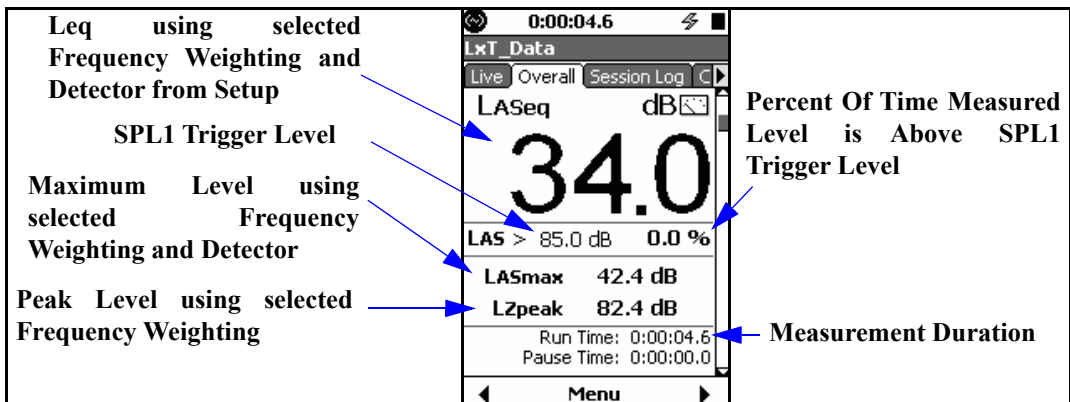

FIGURE 5-11 Overall Page, Digital Page

The **Digital** page presents a profile of the sound level for the run time of the measurement. The run time for the average calculation is shown at the top of the screen. The graph is updated once per second and the calculation of the average sound level is updated approximately four times per second.

Leq

The **Leq** Page presents the maximum, minimum, and peak sound levels, as shown in Figure 5-12. On this page, you can view the current sound levels and instantaneous peak values to note their effect on the maximum and minimum sound levels, and the maximum peak level.

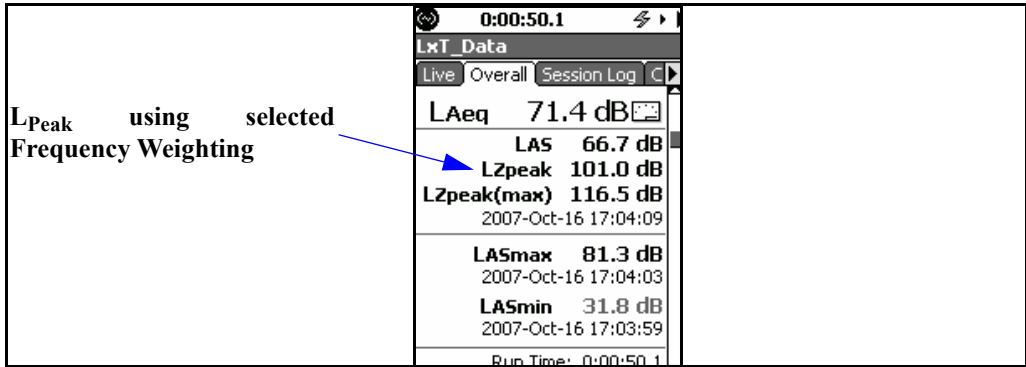



FIGURE 5-12 Overall Tab, Leq Page

The $L_{Zpeak(max)}$ is the highest level the peak detector has measured during the run time of the measurement. The date and time of occurrence is recorded with this event.

The $L_{Zpeak(max)}$ is also considered the peak hold. Whenever data is reset, this parameter is cleared. To reset data, press the  (RESET) key.

The L_{ASmax} is the highest level the RMS detector has measured during the run time of the measurement. The date and time of occurrence is recorded with this event.

The L_{ASmax} is also considered the max hold. Whenever data is reset, this parameter is cleared. To reset data, press the  (RESET) key.

The L_{ASmin} is the lowest level the RMS detector has measured during the run time of the measurement. The date and time of occurrence is recorded with this event.

1/1 Octave (Optional)

The 1/1 Octave Band Analyzer page appears only when the optional firmware LxT-OB1 or LxT-OB3 has been enabled and this measurement mode has been selected in the setup.

The 1/1 Octave page displays bar graphs of sound level in 1/1 octave frequency bands, as shown in Figure 5-13.

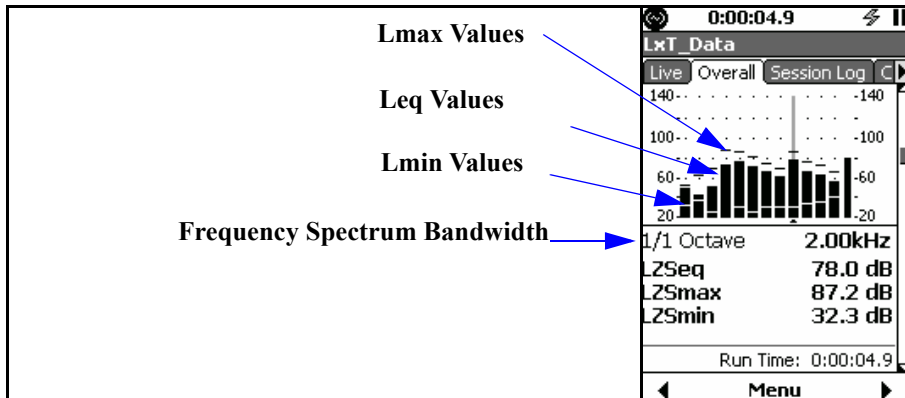

FIGURE 5-13 Overall Tab, 1/1 Octave Page

Leq

L_{eq} is the energy average sound level of the frequency band for the duration of the measurement.

Lmin

L_{min} is the minimum sound level of the frequency band for the duration of the measurement.

Lmax

The value of L_{max} for each frequency band is the maximum value that occurred in that band during the entire measurement period. Since individual frequency bands may reach their maximum levels at different times, this spectrum might be one that never occurred at any instant during the measurement period.

1/3 Octave Band Analyzer (Optional)

The 1/3 Octave Band Analyzer page appears only when the sound level meter is loaded with the optional LxT-OB3 firmware and this measurement mode has been selected in the setup.

The data displayed in the 1/3 Octave page is similar to that displayed for 1/1 octave spectrum measurements, except that it represents 1/3 octave data. Figure 5-14 shows the 1/3 Octave page.

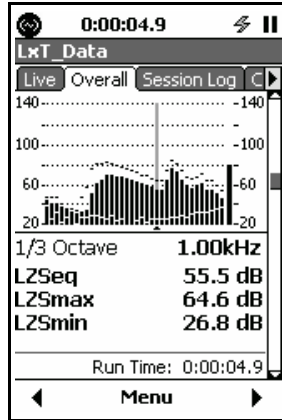

FIGURE 5-14 Overall Tab, 1/3 Octave Page

Dosimeter 1 and 2

There are two separate, but similar, dosimeter data displays in these pages. Figure 5-15 shows the measurement parameters that correspond to the setup named “OSHA-1”.

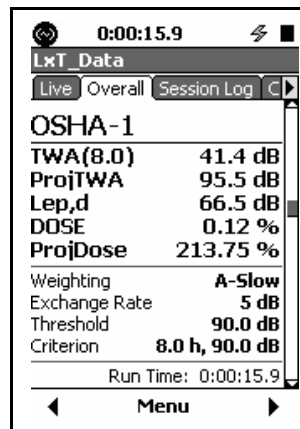

FIGURE 5-15 Overall Tab, Dosimeter 1 & 2 Pages

TWA(8)

The value of TWA(8) (Time Weighted Average for 8 hours) is based on data measured during the run time and calculated for the user-defined Criterion Time, in this case 8 hours. The

value of Criterion Time is set by selecting predefined setups, as described in “Predefined Setups” or by entering numerical values, as described in “Threshold and Criterion”.

For example, suppose a measurement was performed over a time period of ten minutes. The value of TWA(8) would be the same as the TWA measured over an eight hour period if there were no other sound exposure other than that which occurred during that ten minute period.

ProjTWA

The ProjTWA (Projected Time Weighted Average) is calculated from data measured during the measurement run time and calculated for the user-defined Criterion Time, in this case 8 hours. Continuing with the example in the previous paragraph, the ProjTWA for that ten minute measurement represents the value of TWA that would be measured if the noise measured during the ten minute period had continued for eight hours.

$L_{ep,d}$

The Daily Personal Noise Exposure, $L_{ep,d}$ is calculated from data measured during the run time of the measurement.

DOSE

Dose is based on data measured during the run time calculated for the user-defined Criterion Time and Criterion Level (100% definition). For example, suppose a measurement was performed over a time period of ten minutes. The value of Dose would be the same as the Dose measured over an eight hour period if there were no other sound exposure other than that which occurred during that ten minute period.

ProjDOSE

Projected Dose is based on data measured during the run time and calculated for the user-defined Criterion Time and Criterion Level (100% definition). Continuing with the example in the above paragraph, the Projected Dose for that ten minute measurement represents the value of Dose that would be measured if the noise measured during the ten minute period had continued for eight hours.

The remainder of the display shows the parameters used for the measurement: Frequency Weighting, Exchange Rate, Threshold and Criterion (time and level).

SEL (Sound Exposure)

Figure 5-16 shows the **SEL** page. The **SEL** page displays Sound Exposure metrics, (in this instance for A-weighted, Slow).

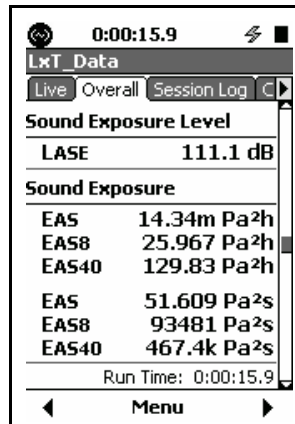

FIGURE 5-16 Overall Tab, SEL Page

L_{ASE} is the sound exposure level (previously known as SEL). The Sound Exposure metrics indicate the actual and extrapolated (8 and 40 hours) exposure accumulated in terms of hours and seconds. These are discussed in “Sound Exposure (SE)” and “Sound Exposure Level (SEL, LE)”.

SEA

The SEA parameter is used mainly in the Canadian province of Quebec.

The SEA page is an integration of 1 second peaks that exceeded 120 dB, as shown in Figure 5-17. Both the SEA value and the frequency weighting used for the measurement are displayed. See “SEA” in the Glossary for a detailed description.

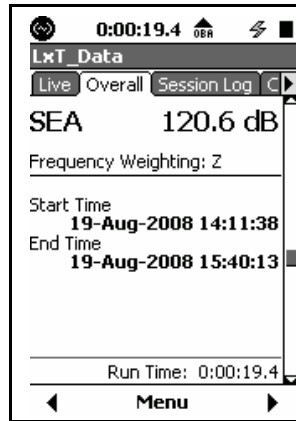

FIGURE 5-17 Overall Tab, SEA Page

Percentiles

The **Percentiles** page displays the Ln statistics for the measurement based on the run time, as shown in Figure 5-18. Also shown are the maximum and minimum sound levels measured. An Ln is the level that was exceeded “n” percent of the time.

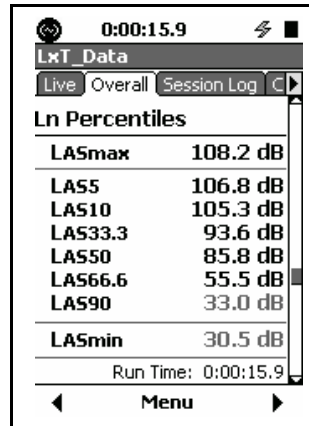

FIGURE 5-18 Overall Tab, Percentiles Page

Exceedances

Exceedances occur when the instantaneous sound levels are greater than set trigger levels. The **Exceedances** page shows the number of exceedances that have occurred during the measurement and the total duration of exceedances.

Exceedances are shown for two threshold levels of the RMS detector and three for the peak detector, as shown in Figure 5-19.

The exceedances count and time shown on this page, as well as those exported in data files, are computed according to your current weighting and detector settings. An exceedance begins when the measured level is greater than the specified threshold and ends when the level is less than or equal to -2 dB of the measured threshold. This prevents excessive exceedance counts when the measured level is at or near the threshold.

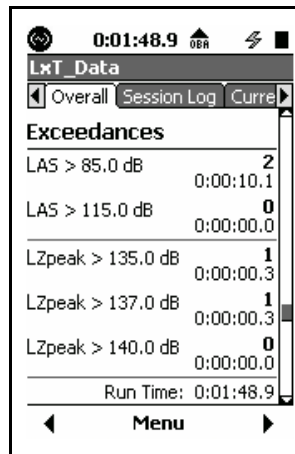

FIGURE 5-19 Overall Tab, Exceedances Page

Overloads

The **Overloads** page displays any overloads that might have occurred during the measurement, as shown Figure 5-20.

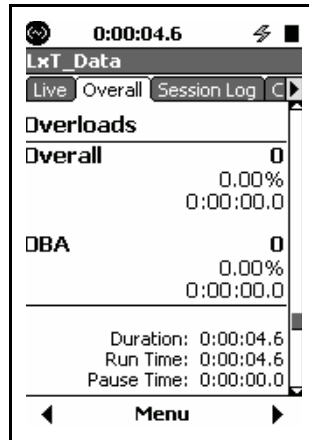

FIGURE 5-20 Overall Tab, Overloads Page

Community Noise

The times intervals associated with the Day, Evening and Night periods are set as described in “Triggers Tab”.

The **Community Noise** page displays three equivalent levels calculated for the total measurement time, as shown in Figure 5-21.

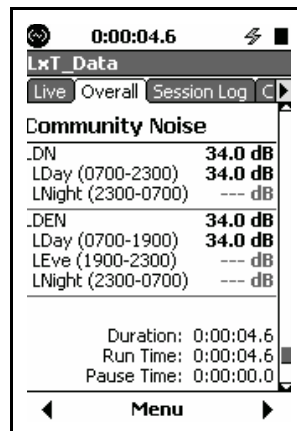

FIGURE 5-21 Community Noise Page

The Community Noise page appears only when the optional firmware LXT-CN has been loaded on the sound level meter and this measurement mode has been selected in the setup.

C minus A and Impulsivity

Figure 5-22 shows the **C minus A** level and **Impulsivity** pages.

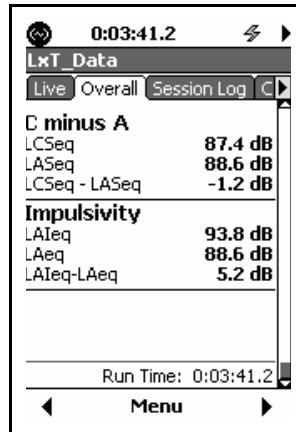

FIGURE 5-22 C-A Level and Impulsivity Page

The integrated levels for L_{Aeq} are always calculated using the linear detector, regardless of the value selected in the SLM Setup. The $LAIEq$ value is from the impulse detector.

L_{CSeq} and L_{ASeq} are equivalent levels measured using Slow RMS averaging and using frequency weightings of C and A, respectively. The difference between them, $L_{CSeq} - L_{ASeq}$, is often used as an indicator of the amount of low frequency content in sounds.

It is also used as a parameter for the selection of hearing protectors, since noise fields having large amounts of low frequency sound can require more effective hearing protectors than would otherwise be indicated by the measured L_{ASeq} level alone.

The parameter $LAFTMS$ only appears when **Takt Maximal** Data has been selected on the **Preferences** tab.

Memory

The **Memory** page presents the quantity of each type of measurement made and the memory status, as shown in Figure 5-23.



FIGURE 5-23 Overall Tab, Memory Page

Session Log Tab

The Session Log is a record of sound measurement actions, as shown in Figure 5-24.

Select the ► icon and press the Enter key to play a recording.

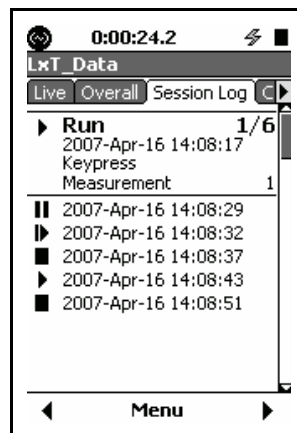

FIGURE 5-24 Session Log Tab

A time-stamped record is made for every Run, Pause, Stop, Voice Message or Marker action. The source responsible for each action is also recorded, which may be any of the following:

- **Key press**
- **USB command**
- **Run timer compete**
- **Low battery**
- **Out of memory**
- **Preamplifier disconnect**

The icons in the left column of the display indicate the action: Run, Pause, Voice Recording, etc. The date and time of the action is displayed next to the icon.

Each measurement segment (from Run to Stop) is numbered, as is each voice message.

Navigate through the list and expand each item. The number in the upper right corner of the expanded item indicates which item is being viewed out of how many total items are in the list.

View Spectrum Normalized (Optional)

The Live Spectrum continues to change in time following the normalization, whereas the Reference spectrum remains the same.

The View Normalized function permits the display of the difference between two spectra by subtracting a user-selected reference spectrum from the measured spectrum. This function can be used with both 1/1 and 1/3 octave spectra, although the measured spectrum and the reference spectrum must have the same bandwidth: 1/1 or 1/3 octave.

View Spectrum Normalization is context sensitive and displays the normalized spectrum for the data from the tab where it was activated, whether **Live**, **Overall**, **Measurement History**, or others.

A and C frequency weighting curves can also be used for references, as described in "Normalizing using Frequency Weighting" on page 5-24.

A standard spectrum displayed on the **Live** tab appears as shown in FIGURE 5-25.

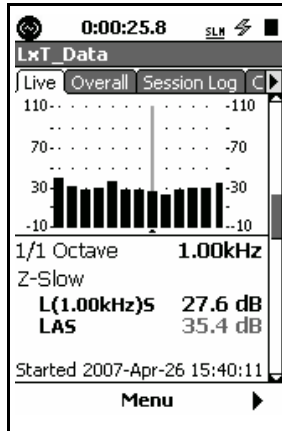

FIGURE 5-25 Live Spectrum Display

To access the View Normalized display, press the center softkey **Menu** to display the menu shown in FIGURE 5-26 when viewing 1/1 or 1/3 octave data.

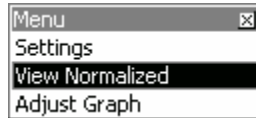

FIGURE 5-26 Menu

Select **View Normalized**. This displays the spectrum in the normalized view, as shown in FIGURE 5-27.

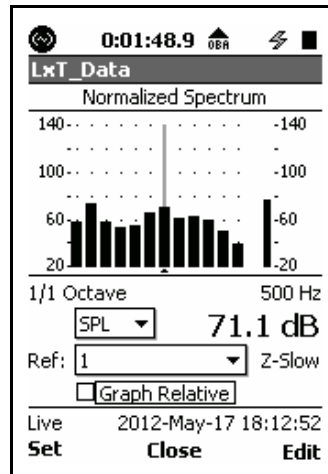

FIGURE 5-27 Normalized Live Spectrum Display

By default the display represents a spectrum normalized to reference spectrum 1. If reference spectrum 1 has not been previously defined, the display shows the actual live SPL spectrum.

Selecting the Spectrum Type

In the live display, it is not necessary to select a spectrum type since only SPL is available.

Selecting the Reference Spectrum

Select the field referenced in Figure 5-27 and press **ENTER** to open the menu shown in FIGURE 5-28.



FIGURE 5-28 Spectrum Type Menu

Select from the three spectrum types: **Leq**, **Lmax** and **Lmin**.

Select the **Ref:** data field and press **ENTER** to open the Reference Menu, as shown in FIGURE 5-29.

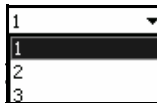

FIGURE 5-29 Live Reference Menu

The items listed in this menu are as follows:

- 1
- 2
- 3
- 4
- A
- C
- -A
- -C

The first four items permit the user to define four reference spectra.

The last four items permit the user to use add positive or negative A or C frequency weightings to the displayed spectrum.

Setting a Reference Spectrum

By pressing the **Set** softkey, the current spectrum is set as the reference spectrum for the selected reference (1, 2, 3 or 4).

Following this procedure, reference spectra 1, 2, 3 and 4 can be defined. Once defined, the user can choose to display the live SPL spectrum normalized to any one of these four reference spectra.

Normalizing using Frequency Weighting

The A and C reference spectrum represent the A and C frequency ratings sampled at the center frequency of the selected filter.

Selecting A or C approximates an A or C weighted spectrum when the original data is unweighted, z weighted. Using -A and -C removes the effects of A or C frequency weighting.

FIGURE 5-30 shows an -A reference display for an A-weighted version of a spectrum.

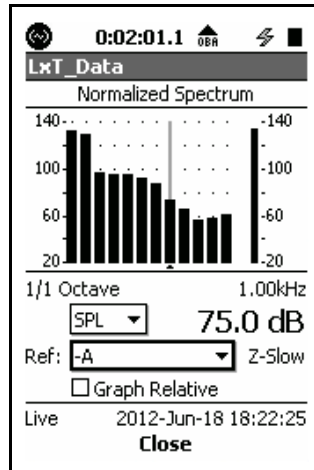

FIGURE 5-30 Normalized Spectrum with -A Weighting

Graph Relative

Selecting **Graph Relative** changes the graph to show the difference between the current data and the reference, with the center of the graph being 0dB. This feature can be used to easily determine if a reference has been exceeded.

Making Measurements

This chapter describes how to make and store accurate sound level measurements.

Preparation

Before making a measurement, make sure of the following:

- The instrument hardware has been properly assembled as described in "Preparing for First Use".
- The instrument has been calibrated as described in Chapter 7 "Calibration".
- The measurement has been configured as described in "Basic Measurement Setup".

Positioning the LxT

This section describes how to position the LxT for optimal sound level measurements.

Observer Position

In order to avoid the effect of sound reflections from the body of the operator interfering with the measurement, the meter should be located as far as possible from the body. Thus, when actually performing the measurement, the operator should place himself at a distance behind the tripod-mounted meter, or extend the hand-held meter as far from the body as is comfortable.

Microphone Extension Cable

If desired, a microphone extension cable may be placed between the meter and the preamplifier/microphone. No correction is required when using Larson Davis Model EXC<xxx> shielded microphone extension cables in combined lengths up to 200 feet. (The variable <xxx> represents the length in feet of the cable.)

Use of a Windscreen

Wind blowing across the microphone generates pressure fluctuations on the microphone diaphragm that can produce errors in the measurement. As a result, when performing measurements in the presence of low level airflows, it is recommended that a windscreen be placed over the microphone. Larson Davis provides the WS001 windscreen, a 3 1/2" diameter ball made of open cell foam which can be placed over the microphone and preamplifier as shown in FIGURE 6-1.



FIGURE 6-1 Position of Windscreen

Performing Measurements

This section describes the steps for performing basic sound level measurements.

Starting the Measurement

The LxT uses a single range for sound level measurements, so there is no need to select a range, as part of making a measurement.

The **Live** tab displays current acoustic data that is not being recorded or stored. Pressing the  (RUN/PAUSE) key causes the LxT to begin storing data, which is displayed on the **Overall** tab.

Measurement Range

The measurement ranges in which the LxT meets the standards, which depend upon the selected frequency weighting, are shown in Table A-4, “LxT Performance Specifications,” on page A-4. Measurements which include levels outside this range should not be considered accurate.

Overload Indication

When input signals exceed the input range of the LxT, the Input Overload Icon appears at the top of the display.



If a measurement is running and an overload occurs, the icon flashes on and off for as long as the overload condition exists, or one second minimum. When the overload has been removed, the icon remains present (not flashing) to indicate that an overload has occurred during the measurement. A reset clears the icon from the display.

Under Range Indication

When input signals drop below the level that the LxT can measure within specified tolerances, an under range condition exists. When this happens the Under Range Icon appears.



As long as the under range condition exists, the icon flashes. When the measured level no longer produces an under range condition, the icon is removed from the display.

At any time when a measured parameter is in an under range condition, it's numeric display appears in gray rather than the usual black, as shown FIGURE 6-2.

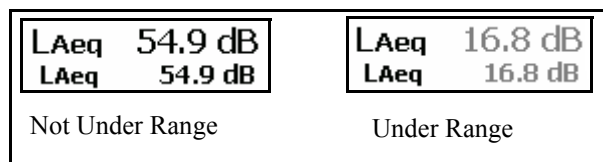

FIGURE 6-2 Normal vs. Under Range Data Display

Pausing Measurements

Measurements may be paused and then run again multiple times.

At any time the measurement of overall data can be temporarily suspended by pressing the **⏸** key. Note that the run clock also pauses. However, instantaneous data continues to be displayed on the **Live** tab.

Pressing the **⏸** key one more time starts the measurement again; overall data continues to accumulate. The run clock also begins again from the time indicated when the pause occurred. The overall data is not affected by any acoustic events occurring during the time period that the LxT is paused.

Back Erase

Back Erase is disabled when Measurement History has been enabled in the LxT setup, as described in Chapter 10 Measurement History”.

The back erase function permits the user to rapidly delete from the measurement the effects of acoustical events that have occurred during the previous five or ten seconds. The back erase can be implemented when the measurement is paused, as described in the preceding section. When the measurement is paused, the center softkey is labeled **Back-5s**, as shown in FIGURE 6-3.

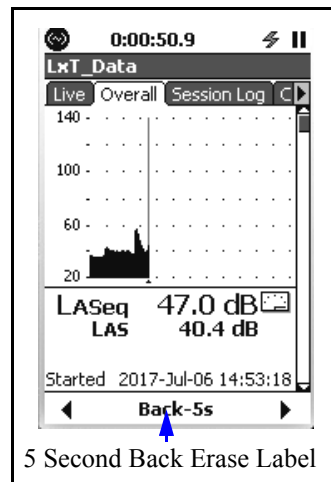

FIGURE 6-3 Five Second Back Erase Label

The Back-5s label does not indicate the state of the instrument but that an action can now be taken to delete the last five second segment.

Press the center softkey to implement a five second back erase.

> Ten Seconds Since Last Stop or Pause

After pressing the center softkey to implement a five second back erase, if the measurement duration since the last Stop or Pause has been more than ten seconds, the center softkey is then labeled **Back-10s**, as shown in FIGURE 6-4.

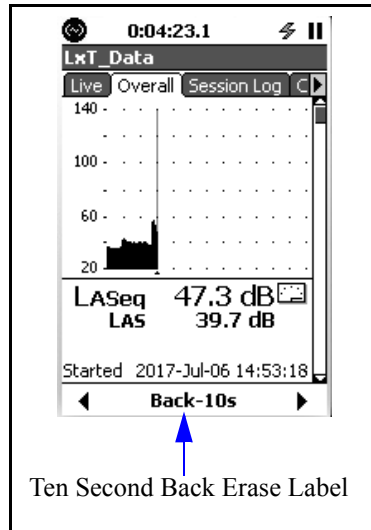



FIGURE 6-4 Ten Second Back Erase Label

The Back-10 label does not indicate the state of the instrument but that an action can now be taken to delete the last ten second segment.

The user can take one of the following actions:

- Press the  key to accept the five second back erase and continue the measurement.
- Press the center softkey to extend the back erase to ten seconds. The center softkey is then labeled **Undo**, as shown in FIGURE 6-5.

< Ten Seconds Since Last Stop or Pause

After pressing the center softkey, if the measurement duration since the last Stop or Pause has been less than ten seconds, the center softkey is then labeled **Undo**, as shown in FIGURE 6-5.

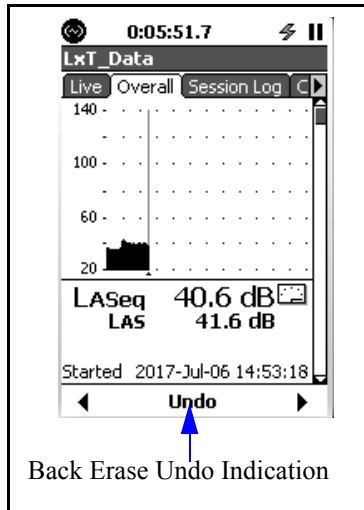



FIGURE 6-5 Back Erase Undo Indication

The user can take one of the following actions:

- Press the  key to continue the measurement with the five second segment removed.

Press the center softkey to implement the **Undo** action and then press the  key to continue the measurement without removing the previous five second time segment.

Time History Records

The time history records from the point that data was restored to the last record are marked as back erase records in the marker field.

Resetting Measurements

A measurement is most often reset when a noise event which is not typical of the desired measurement takes place. For example, an aircraft passing overhead when attempting to measure the background noise in a normally quiet area may cause for resetting.

To reset a measurement in progress, press the  (RESET) key. This erases all data previously measured and resets the run time clock to zero. A reset does not reset stored data files.

A reset can be initiated when the LxT is running, paused or stopped. However, it must be stopped for the reset operation to be performed.

Starting a New Measurement

The  key must be pressed to start a new measurement.

Stopping Measurements

The LxT can be stopped when either running or paused.

Press the  (STOP) key to suspend the overall measurement.

Pressing the  key afterwards continues the overall measurement which had been stopped.

Storing Measurements

Measurements can only be stored when they have been stopped.

To store the measurement, press the  key one more time. The Save File menu is then displayed, as shown in FIGURE 6-6 "Save File Menu" .



FIGURE 6-6 Save File Menu

After a file has been successfully stored, the LxT automatically resets when the **ENTER** key is pressed to begin another measurement.

Overwriting a Saved File

The data is stored under the file name defined in the section "General Tab" along with a file number. The file number automatically begins at 000 for the first measurement stored. The file number is also indexed so that whenever a measurement is stored, the file number assigned is the next in sequence following the measurement previously stored.

If you wish to use this data to replace a data file already saved in the LxT, select the box with the title "... " and press **ENTER** (ENTER). This opens a window listing all the data files already saved in the LxT, as shown in FIGURE 6-7.

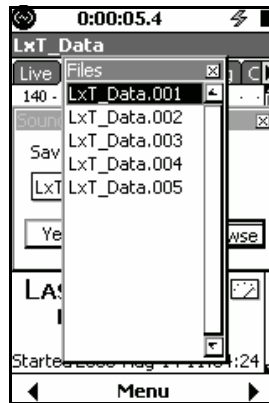

FIGURE 6-7 Saved Data Files

Select the file that is to be overwritten. This replaces the file name and number that previously appeared with the one shown on the display, as shown in FIGURE 6-8.

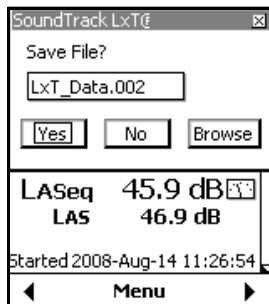

FIGURE 6-8 Overwriting a Saved File

To continue with the overwrite operation, select **Yes** and press **ENTER**.

Data Storage After Improper Shutdown

When the LxT has been shutdown improperly during a measurement, for example during a power outage, the procedure for handling the data depends upon the setup being used at the time of the measurement. This section describes two cases.

Case 1

If the Run Mode is:

Continuous

or

Single Block Timer

or

Daily

and

Daily Autostore is enabled

Normal Operation

Under normal operation the stored data files are stored with the following name format:

yymmdd00.LD0

where yymmdd is the date the file was stored.

Improper Shutdown

Following an improper shutdown, when the instrument is next turned On, the data is automatically stored using the following name format:

yymmddxx.LD0

where yymmdd is the date the data is stored and xx is a number, beginning at 01, which is automatically incremented for subsequent instances of improper shutdown.

Case 2

This case covers all setups other than those described in Case 1.

Improper Shutdown

Following an improper shutdown, when the instrument is next turned On:

Step 1 The user is prompted to save the data.

- If the user responds by selecting to store the data, the data is stored and the instrument is reset
- If there is no user response to the prompt within ten seconds, the instrument is reset
- If the user responds by selecting not to store the data, the sequence moves to Step 2.

Step 2 The user is prompted to reset the instrument

- If the user responds by selecting to reset the instrument, the instrument is reset.
- If there is no user response to the prompt within ten seconds, the instrument is reset.
- If the user responds by selecting not to reset the instrument, the sequence moves back to Step 1.

This sequence is diagramed below

When present, the user must eventually select to store the data, reset the instrument, or take no action, in which case the instrument is automatically reset.

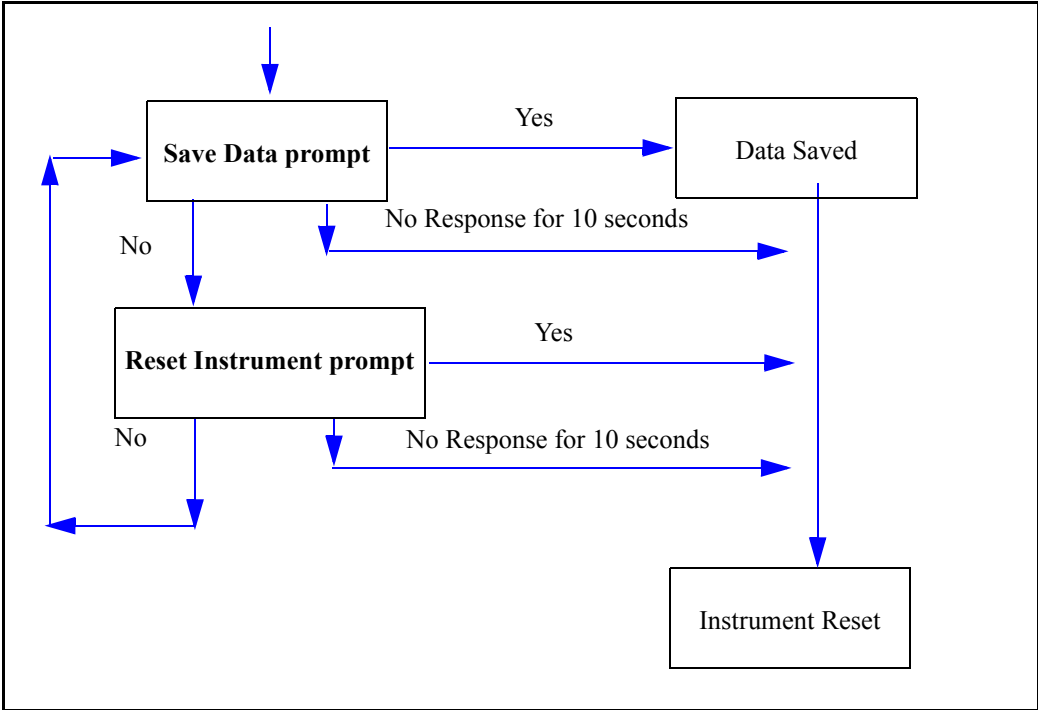

FIGURE 6-9 Improper Shutdown Sequence, Case 2

Calibration

This chapter describes both the purposes and steps for calibrating the SoundTrack LxT[®] and SoundExpert[®] LxT.

Calibration Overview

Sensitivity Determination

The primary role of sound level meter calibration is to establish a numerical relationship between the sound level at the diaphragm of the microphone and the voltage measured by the meter so that the sound pressure level can be read directly from the display of the meter in units of dB. The result of a calibration is the determination of the sensitivity of the meter, including microphone and preamplifier, typically in units of dB re 1V/Pa or mV/Pa.

Overload/Under Range Conditions

A secondary role of calibration is to determine the sound level that would overload the instrument and the minimum sound level that can be accurately measured, referred to as the under range level. This requires a knowledge of the electrical noise levels of the microphone, preamplifier, and the instrument circuitry.

Calibration Stability

The LxT should maintain a stable value of sensitivity over long periods of time. Significant changes in sensitivity, or a pattern of small but regular sensitivity changes, are indicative of problems with the measurement system, calling for laboratory calibration and possibly service. To assist the user in identifying these situations, the LxT provides two notifications:

Calibration History

Data and date/time of the most recent ten calibrations.

Large Change Notification

During calibration, an automatic comparison is made between the sensitivity determined by the calibration and a published value of sensitivity. An on-screen window appears to warn the user when the difference between these two values exceed 3 dB.

Control Panel - Calibrate

To activate the Calibration function, press the  (TOOLS) key and select the Calibrate icon as shown in Figure 7-1.

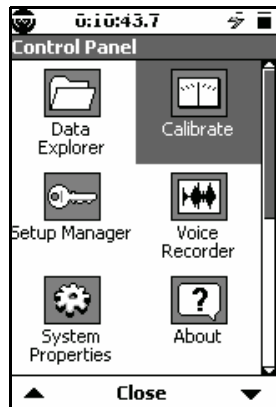



FIGURE 7-1 Control Panel

Press  (ENTER) to open the Calibrate tabs.

The four Calibration tabs are shown in FIGURE 7-2.

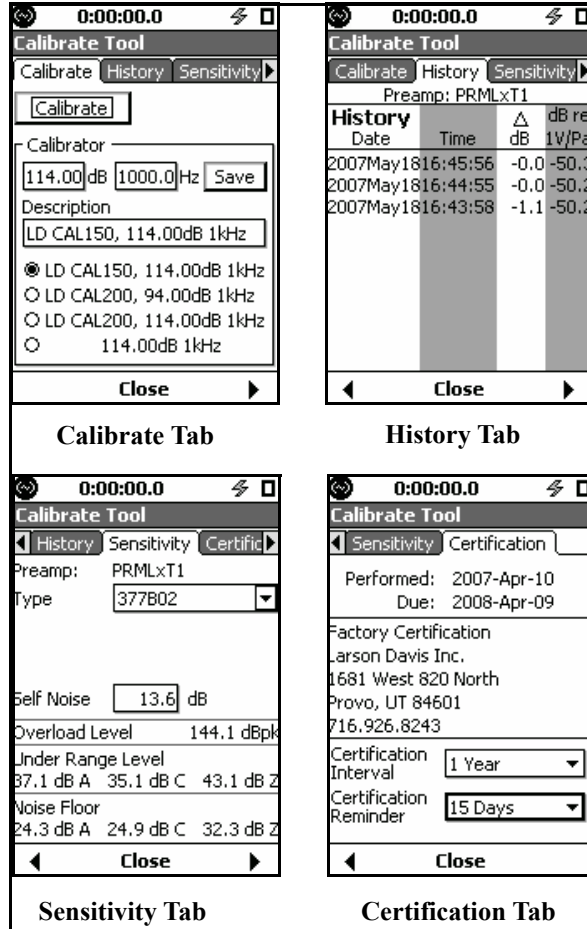

FIGURE 7-2 Calibration Tabs

Calibrate Tab

The **Calibrate** tab is used when performing an acoustic calibration, including the selection of the sound level calibrator to be used and the implementation of the calibration procedure.

History Tab

To create a history record for a calibration, it must be saved; calibrations must also be saved to export post-calibration data to software.

The **History** tab lists the results, along with the date and time, of the ten most recent calibrations performed using the same type of preamplifier as presently connected to the LxT. The preamplifier name appears at the top of the tab (PRMLxT1 in this example). The preamplifier type is read automatically when the instrument is booted up, or following a change in preamplifier. The value of sensitivity in dB re. 1 V/Pa and the variation of the sensitivity determined from that calibration relative to the calibration prior to that, Δ dB, are presented for each calibration.

Sensitivity Tab

When performing an acoustic calibration, the **Sensitivity** tab is used to select the microphone being used.

Certification Tab

The **Certification** tab shows the date of the last certification, the due date for the next certification, and information about the calibration facility. You can also enter your certification interval and certification reminder from this tab.

Exiting from the Calibration Function

Press the **Close** Softkey to exit from any of the calibration tabs to the Control Panel.

Acoustic Calibration

This is the most commonly used calibration method, and the one required by most national and international standards prior to performing a measurement. A sound level calibrator is used to apply an acoustical signal of a known amplitude and frequency to the microphone. From the voltage level measured by the meter, the sensitivity can be determined. With this technique, it is assumed that the calibrator is functioning correctly; any variation in level results in an improper calibration and an erroneous value of sensitivity. For this reason, the user is advised to compare the newly determined sensitivity with the previous sensitivity to ensure that significant variations have not occurred.

Frequency Weighting

The LxT automatically switches to C frequency weighting and Fast detector response for calibration. This permits 250 Hz and 1000 Hz calibrators to be used. The Fast detector response reduces the stabilization time required before calibration.

After calibration, the LxT returns to the original frequency and time weighting set by the user.

Calibrator

The **Calibrator** section of the **Calibrate** tab includes an area to enter information about a calibrator and a list of calibrators. The user may select a calibrator from the list or enter new information about a calibrator.

Recommended Calibrator

Table 7-1 'Recommended Calibrators for Use with LxT1 and LxT2' lists the sound level calibrators which Larson Davis recommends for calibrating the LxT1 and LxT2.

When using a 1/4" microphone, the adaptor ADP024, a 1/4" microphone adaptor for the 1/2" opening in the CAL150 and CAL200 calibrators, is also required.

Calibrator	Instrument	Calibrator Precision	Output	Frequency
CAL200	LxT1, LxT2	Class 1	94/114 dB	1 kHz
CAL150	LxT2	Class 2	94/114 dB	1 kHz

Table 7-1 Recommended Calibrators for Use with LxT1 and LxT2

Calibrating the LxT1 and 377B02 microphone

The CAL200 provides a nominal pressure level of 94 dB or 114 dB. The exact levels are printed on the Larson Davis calibration sheet that came with the calibrator. When using a free-field microphone, the pressure level at the microphone diaphragm is slightly different. Thus, a free field correction of -0.12 dB (0.03 dB uncertainty at 95% confidence level) should be applied to either of these levels. Pressure and random incidence microphones do not require this correction. If the calibrator and instrument are near room

temperature (23° C) and near sea level (101.3 kPa) then no other corrections need to be made. For example, if the calibration sheet for the CAL200 indicates 113.98 dB for its level when set to 114 dB then set the Cal Level in the LxT to 113.86 dB and 1000 Hz.

When the microphone and instrument are at a temperature other than near room temperature or static pressures not near sea level, then corrections need to be added for the ambient temperature and the prevailing static pressure. Check the calibration data shipped from Larson Davis with the CAL200 to get these corrections. The corrections can be added to the level obtained in the previous paragraph to get the actual level of the CAL200.

The 377B02 microphone's sensitivity varies with static pressure. If the instrument is calibrated in one environment and moved to another, then the sensitivity changes (after stabilization) depending on the change of temperature and pressure. The coefficient of static pressure is -0.01 dB/kPa. If the system is calibrated at 85 kPa for instance then it is 0.16 dB less sensitive at sea level (101.3 kPa). The sensitivity of the 377B02 and LxT vary slightly with temperature also. The coefficient of temperature is +0.009 dB/°C. If the system is calibrated at 18° C then it is 0.045 dB more sensitive at 23° C.

The Larson Davis 3" Wind Screen has less than 0.05dB effect on the system response at 1 kHz.

Set the CAL200 level switch to 94 or 114 dB.

Calibrating the LxT2 and 375B02 microphone

The CAL200 and CAL150 provide a nominal pressure level of 94 dB or 114 dB. The exact levels are printed on the Larson Davis calibration sheet that came with the calibrator. When using a free-field microphone, the pressure level at the microphone diaphragm is slightly different. Thus, a free field correction of -0.12 dB (0.03 dB uncertainty at 95% confidence level) should be applied to either of these levels. If the calibrator and instrument are near room temperature (23° C) and near sea level (101.3 kPa) then no other corrections need to be made. For example, if the calibration sheet for the CAL200 or CAL150 indicates 113.98 dB for its level when set to 114 dB, then set the Cal Level in the LxT to 113.86 dB and 1000 Hz.

When the microphone and instrument are at a temperature other than near room temperature or static pressures not near sea level, then corrections need to be added for the ambient temperature and the prevailing static pressure. Check the calibration data shipped from Larson Davis with the CAL200 or CAL150 to get these corrections. The corrections can be added to the level obtained in the previous paragraph to get the actual level of the CAL200 or CAL150.

The 375B02 microphone's sensitivity varies with static pressure. If the instrument is calibrated in one environment and moved to another, then the sensitivity changes (after stabilization) depending on the change of temperature and pressure. The coefficient of static pressure is -0.01 dB/kPa. If the system is calibrated at 85 kPa for instance then it is 0.16 dB less sensitive at sea level. The sensitivity of the 375A02 and LxT vary slightly with temperature also. The coefficient of temperature is -0.015 dB/°C. If the system is calibrated at 18° C then it is 0.07 dB less sensitive at 23° C.

The Larson Davis 3" Wind Screen has less than 0.05dB effect on the system response at 1 kHz.

Environmental Parameter Ranges

For proper calibration, the calibration procedure and the correction values apply over the ranges presented in Table 7-2.

Instrument Class	Parameter	Range
Class 1, LxT1 with 377B02 microphone	Static Pressure	65 kPa to 108 kPa 9.4 psi to 15.7 psi
	Temperature	- 10 °C to + 50 °C 14 °F to + 122 °F
	Relative Humidity	25 % to 90%, without condensation from - 10 °C to + 39 °C (14 °F to + 102 °F)

Table 7-2 Environmental Parameter Ranges for Calibration

Instrument Class	Parameter	Range
Class 2, LxT2 with 375B02 microphone	Static Pressure	65 kPa to 108 kPa 9.4 psi to 15.7 psi
	Temperature	0 °C to + 40 °C 32 °F to + 104 °F
	Relative Humidity	25% to 90%, without condensation from - 10 °C to + 39 °C (14 °F to + 102 °F)

Table 7-2 Environmental Parameter Ranges for Calibration

Set the CAL200 level switch to 94 or 114 dB.

Adding a Calibrator

When adding a calibrator to the list, the following information may be entered:

- Calibration Level
- Calibration Frequency
- Calibrator Description

The calibration level and frequency values are as specified in the section ‘Recommended Calibrators for Use with LxT1 and LxT2’ on page 7-5.

On the **Calibrate** tab, select each text box in the **Calibrator** section and enter the correct information about a calibrator; press **ENTER** to complete the entry, as shown in Figure 7-3.

When the calibration level, calibration frequency, and calibrator description have been entered, select the **Save** button and press **ENTER** to save the information to the list of calibrators.

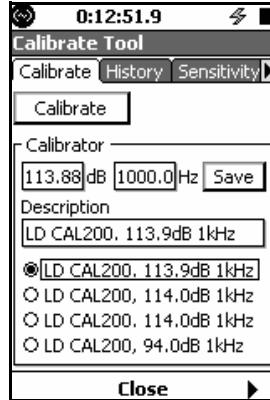

FIGURE 7-3 New Calibrator

If the desired calibrator is already in the list, highlight the calibrator and press **ENTER**. The radio button next to the selected calibrator is filled in and the calibration information appears, as shown above.

Microphone Selection

The microphone being used is selected from the **Sensitivity** tab shown in FIGURE 7-2.

Larson Davis Microphone

If using one of the Larson Davis microphones most frequently used with the LxT, highlight the down arrow portion of the Type data field to obtain a list of microphones such as shown in FIGURE 7-4.

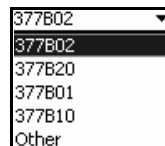

FIGURE 7-4 Microphone Selection List

Select the microphone type being used and press **ENTER**. The nominal value of sensitivity for that type of microphone appears in the Published data field and the Self Noise for

that microphone and preamplifier combination appears in the Self Noise data field.

Other Microphone

In order for the Noise Floor and Under Range Levels to be determined when the microphone is not selected from the drop down list as described in ‘Larson Davis Microphone’ on page 7-9, the user must manually enter a value into the Self Noise data field.

If using a microphone from another manufacturer, or if the Larson Davis microphone type being used does not appear in this list, the name and parameters can be entered manually. The Type data field is a combobox, which means that the down arrow (right) portion can be used to open a drop down list while the left portion can be used for text entry. Use the \leftarrow key to select the left portion of the data field and press ENTER to bring up the cursor. Enter descriptive text to define the microphone and press ENTER .

Performing the Calibration

Refer to the calibrators operating instruction for more information.

Carefully insert the microphone into the microphone opening in the top of the calibrator. Turn on the calibrator.

Select the **Calibrate** button on the LxT and press ENTER . Figure 7-5 shows the **Calibrating** message box. The **Cancel** button is highlighted. Pressing the ENTER aborts the calibration.

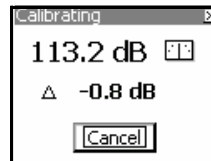

FIGURE 7-5 Calibrating

The present sound level (114.0 dB), the difference between the calibration level and the present sound level (Δ) and an indication of stability are displayed in this message box. When the pointer in the stability indicator is vertical, the sound level is stable.

You can simply verify the calibration by selecting **No**. Also, if no significant changes are seen you may choose to answer **No**. However, to create an historical record for it, or to export post-calibration data, you must save it.

Warning Messages

When the calibration is completed, select **Yes** to save the results of the calibration. Select **No** to cancel the results of the calibration.

After selecting **Yes** to save the results of the calibration, two warning messages may appear.

Outside Range of Normal Sensitivity

When the results of the calibration correspond to a sensitivity greater than 3 dB outside the range of the nominal sensitivity for that microphone, the message shown in FIGURE 7-6 appears.

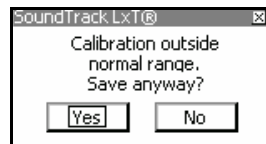

FIGURE 7-6 Outside Normal Sensitivity Range

> 0.5 dB From Previous Calibration Result

When the results of the calibration indicate a change in sensitivity greater than 0.5 dB from the previous calibration results, the message shown in FIGURE 7-7 appears.

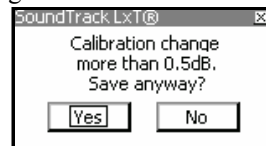

FIGURE 7-7 0.5 dB From Previous Calibration Result

Calibration Results

When the calibration results are saved, the **History** tab, as shown in Figure 7-2, is updated. The parameters for this most recent calibration appear at the top of the list.

Sensitivity Tab

The **Sensitivity** tab, shown in FIGURE 7-8, is used primarily to establish the noise floor of the instrument with the preamplifier and microphone presently being used and, from that, determine the under range levels for A, C and Z-weighting sound level measurements. The overload level is also determined.

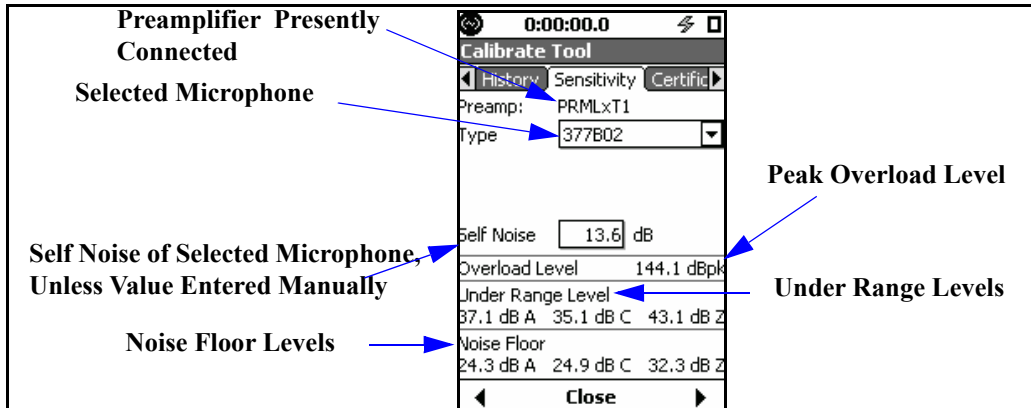

FIGURE 7-8 Sensitivity Tab

Noise Floor

The noise floor is calculated as the energy sum of the microphone self noise, preamplifier self noise and instrument self noise.

When using one of the following preamplifiers, identified automatically when plugged into the LxT,

- Direct
- PRMLxT1
- PRMLxT2B
- PRMLxT1L
- PRMLxT2L

and one of the five most commonly used microphones for that type of preamplifier, user-selected, a database in the LxT provides the nominal sensitivity and the self noise of the preamplifier and microphone pair.

When a calibration has been performed using any of the four preamplifiers listed above, that calibration information is saved for that preamplifier. If the preamplifier is switched from one of these types to another, then the calibration information already saved for that new preamplifier type is recalled. As long as the same microphone is being used with that preamplifier, the calibration should be correct.

Direct Data Input

Self-noise values can also be entered manually when using preamplifiers and/or microphones not included in the LxT data base. See also ‘Direct Data Input’ on page 7-13.

Overload Level

The overload level is the highest peak level which can be measured without overloading the input of the LxT.

Under Range Level

The Under Range Level is the higher of the following:

- (1) Noise Floor plus 10 dB
- (2) Actual point where the log-linearity exceeds maximum permitted value

Except for very low noise level microphones, the under range level is usually determined by (1).

Calibration Without Preamplifier

There may be situations where the microphone preamplifier provided with the LxT is not being used. For example when a hydrophone is being used, no level calibrator is available so the sensitivity must be input directly by the user. When the preamplifier has been disconnected, the **Sensitivity** tab appears as shown in FIGURE 7-9.



FIGURE 7-9 Sensitivity Tab Without Preamp

In this situation, the sensitivity of the transducer and the self noise can be entered directly, if known.

Certification

The **Certification** tab is shown in FIGURE 7-10.



FIGURE 7-10 Certification Tab

A certification interval of one year is recommended but this can be lengthened or disabled depending on applicable requirements.

The user has the opportunity to set the calibration interval and a calibration reminder.

Certification Tab Parameter Selection

The **Certification** tab parameters are selected as shown in FIGURE 7-11.

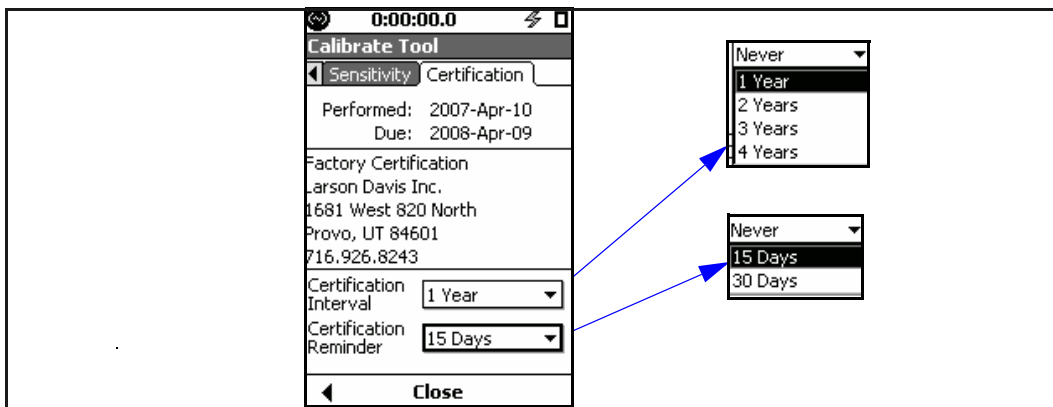

FIGURE 7-11 Certification Tab Parameter Selection

Available values of Certification Interval are as follows:

- 1 Year
- 2 Years
- 3 Years
- 4 Years
- Never

The default value is Never

Available values of Certification Reminder are as follows:

- 15 Days
- 30 Days
- 45 Days
- 60 Days
- Never

The default value is Never

Notification

When appropriate, the message “Certification will expire in xx days” or “Certification has expired” is displayed as follows:

- When the instrument powers up
- When the Calibrate Tool is selected, as shown in FIGURE 7-1.

These messages appears as shown in FIGURE 7-12 and FIGURE 7-13.

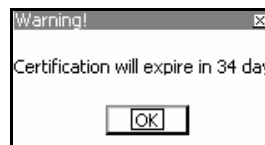

FIGURE 7-12 Message: Calibration Will Expire



FIGURE 7-13 Message: Calibration Has Expired

Voice Recording

The LxT provides a voice recorder as a convenient way to annotate measurements. Voice recordings can be made with or without a headset, are sampled at 8 kHz, and can be up to 20 seconds long.

Launching the Voice Recorder Dialog

To activate the voice recorder dialog, press the  (TOOLS) key and navigate to the Voice Recorder icon as shown in FIGURE 8-1.

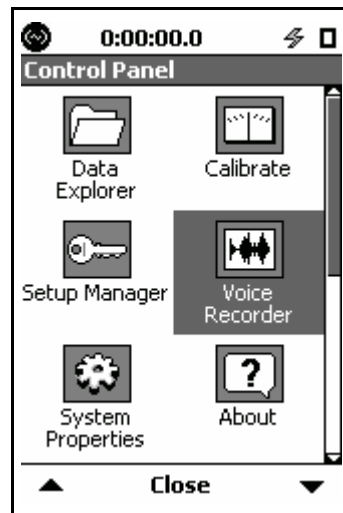

FIGURE 8-1 Control Panel

The Voice Record list is initially empty.

Select the Voice Recorder icon and press **ENTER** to open the dialog shown in FIGURE 8-2.

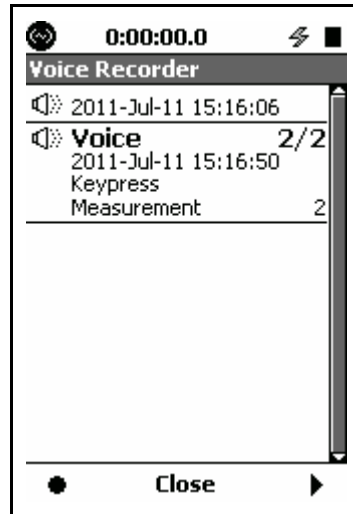

FIGURE 8-2 Voice Recorder

Making a Voice Recording

With Headset

When using a headset, the Jack Function must be set to “Headset” as described in Chapter 12 System Properties”.

When a headset is connected to the headset jack, voice recordings are made using the headset microphone and are played back through the headset.

Without Headset

When a headset is not connected, voice recordings are made using the instrument microphone.

Recording

Pressing the left softkey (labeled with the **●** icon) starts a recording.

The recording stops automatically after 20 seconds has elapsed, or can be stopped manually by pressing **ENTER**.

Playing a Voice Recording

Voice recordings can also be played back from the Session Log.

FIGURE 8-2 shows that voice records are presented in a list on the dialog. To play back a recording via the headset jack, select the desired recording in the list and press the right soft key (labeled with the ► icon).

Storing Voice Recordings

When measurement data is stored, all voice records associated with that data are stored in the data file and the voice records list are cleared.

Time History

This chapter describes the measurement features associated with the optional data logging firmware LXT-LOG and LXT-HSLOG.

Parameters Logged

With the optional firmware LXT-LOG enabled, the Time History mode permits the LxT to automatically log up to twenty parameters, both acoustic and non-acoustic, at time intervals ranging from 1 second to twenty-four hours.

With the optional firmware LXT-HSLOG also enabled, the time interval for automatic logging is extended to 100 milliseconds.

Acoustical Parameters

Table 9-1 shows the acoustical broadband level parameters that are logged for Time History.

Parameter Label	Description
Leq	Uses selected frequency weighting: A, C, or Z
Lmax & Lmin	Uses selected frequency weighting: A, C, or Z and selected detector: F, S, or I
Lpeak	Uses selected Peak Weighting: A, C, or Z
LwS, LwF, & Lwl	Instantaneous level: w = selected frequency weighting
LAFTM5	Taktmaximal 5
Ltwa1 & Ltwa2	The weighted averages associated with Dose 1 and Dose 2
LCeq - LAeq	C-A for low frequency indication
LAleq - LAeq	Impulse - rms for indication of impulsivity.

Table 9-1: Logged Broadband Level Parameters for Time History

Table 9-2 shows additional acoustical parameters that are logged for Time History.

Parameter Label	Description
OBA 1/1 Leq	Optional firmware LxT-OB1 is required.
OBA 1/1 max	Optional firmware LxT-OB1 is required.
OBA 1/1 min	Optional firmware LxT-OB1 is required.
OBA 1/3 Leq	Optional firmware LxT-OB3 is required.
OBA 1/3 max	Optional firmware LxT-OB3 is required.
OBA 1/3 min	Optional firmware LxT-OB3 is required.
Battery	Stores internal battery voltage.
Internal Temp	Stores LxT internal temperature.
Tms	Millisecond time resolution.

Table 9-2: Additional Logged Parameters for Time History

Instantaneous Values

When the LXT-HSLOG firmware is enabled, three instantaneous values are available. These are continuously varying sound levels, based on Slow (S), Fast (F) and Impulse (I) detectors and the user-selected frequency weighting, measured at each time interval.

- L_{XS} , L_{XF} , L_{XI} , where X is the user-selected frequency weighting for the sound level measurement

Specialized Acoustic Parameters

The LAFTM5 parameter is displayed only when it has been enabled in the System Properties menu, as described in Takt Maximal Data, and when the time history period is greater than five seconds.

- LAFTM5, Taktmaximal 5 (utilized in Germany) using A-weighting and Fast detector. This also requires selection from the **Preferences** tab, “Takt Maximal Data”.
- L_{twa1} and L_{twa2} : time-weighted averages associated with Dose 1 and Dose 2 exchange rates and thresholds. See “Dosimeter 1 and 2”.
- LCSeq - LASeq
- LXIeq - LXeq, where X is the user-selected frequency weighting for the sound level measurement. This is the impulsivity metric, where the LXeq value is always taken from a linear integration.

Increased Timer Resolution

Tms Resolution

When the optional firmware LXT-HSLOG is enabled and the time history interval has been selected to be 500 ms or less, the parameter **Tms** causes the time value to be measured and saved with higher resolution.

Time History Setup

To set up Time History, navigate to the **Time History** tab, as shown in Figure 9-1.

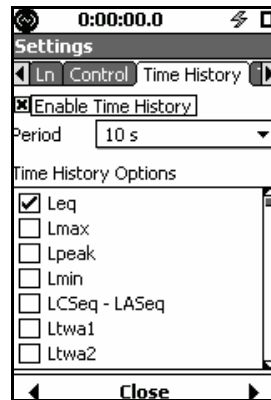

FIGURE 9-1 Time History Setup Tab

Press **ENTER** (ENTER) to enable the Time History functionality and to select the **Enable Time History** check box.

Set Time History Period

To set the Time History Period, select the **Period** data field and press **ENTER** to list all the available values of time, as shown (partially) in Figure 9-2.

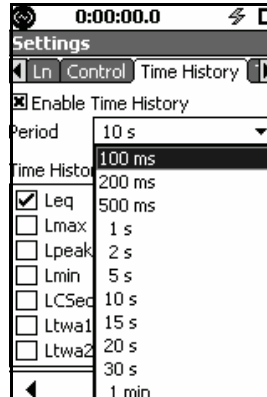

FIGURE 9-2 Time History Period Menu

The values 100 ms, 200 ms and 500 ms appear only when the optional firmware LXT-HSLOG has been enabled.

The following values are available for selection as time increments for Time History:

Milliseconds

100, 200, 500

Seconds

1, 2, 5, 10, 15, 20, 30

Minutes

1, 2, 5, 10, 15, 20, 30

Hours

1, 24

Select the desired increment of time and press **ENTER**.

Select Time History Parameters

The Time History Options Menu is used to select the parameters to be stored for each time increment. Select the Time History Options window and press **ENTER**.

The first item in the options list is highlighted, as shown in Figure 9-3.

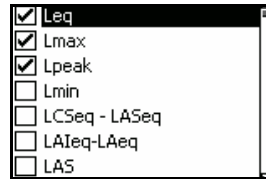

FIGURE 9-3 Time History Options Window

Press \leftarrow to select a check box option. Press \leftarrow to deselect a box already checked.

Exiting Time History Options

When the options have been selected, press ENTER to exit from the Time History Options Menu.

Time History Tab

Single Value Metrics

When the LxT is not equipped with the optional firmware LXT-OB3, or if it is equipped with this option but the measurement of 1/1 and 1/3 octave spectra has been set to Off in the measurement setup, all measured parameters are single value parameters.

This section describes the time history graph that appears for single value metrics such as sound levels and non-acoustic parameters.

Time history data is displayed on the **Time History** tab of the Data Display, as shown in Figure 9-4.

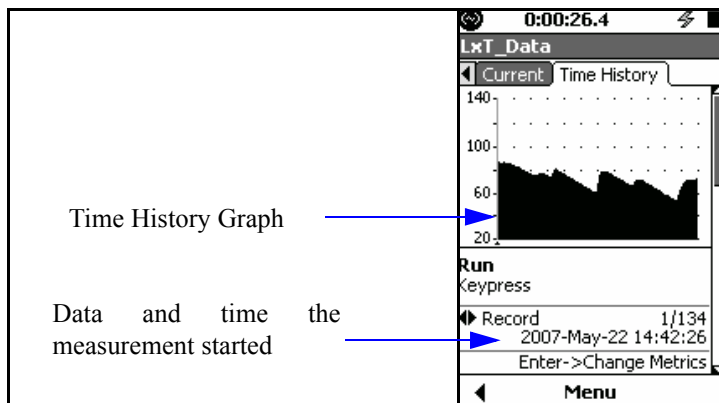

FIGURE 9-4 Time History Display: First Point; Keypress

Graph scaling can be modified as described in section “Graph Scale Adjustment”.

The first display, labeled **Run**, represents the keypress initiating the measurement, with the corresponding data and time. There is no measured data associated with this sample point.

Data Display at Cursor Position

Press the \leftarrow key once to display data measured during the first time interval, as shown in FIGURE 9-5. Once data are displayed, use the \leftarrow and \rightarrow keys to move the cursor right or left, respectively, in increments equal to the time history period.

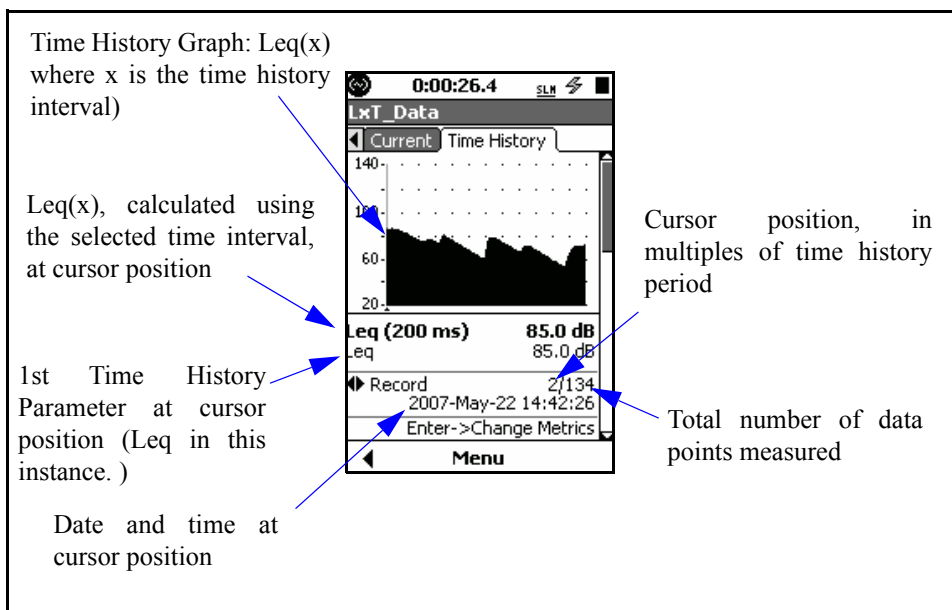

FIGURE 9-5 Measured Data at Cursor Position

Left/Right Arrow Keys

For the display shown in FIGURE 9-5, the \leftarrow and \rightarrow arrow keys have dual roles as listed below. Press ENTER to toggle between them:

- Move cursor and change displayed record
- Step through metrics

At any time, the role of the left and right arrow keys, as well as the means to change it, are indicated in the lower portion of the display, as shown in FIGURE 9-6.

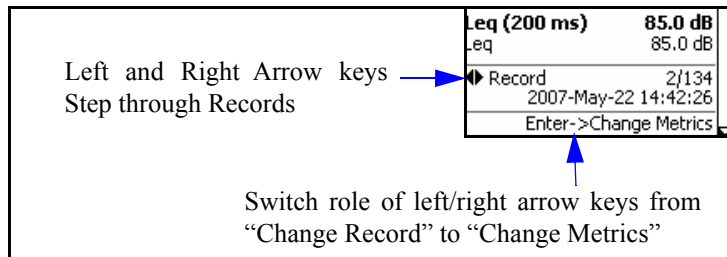



FIGURE 9-6 Left/Right Arrow Change Record

When the left/right arrow symbols appear to the left of **Record**, as in FIGURE 9-5, pressing the left or right arrow key moves the cursor left or right, respectively, selecting a different record to be displayed.

The text “Enter->Change Metrics” indicates that pressing  changes the role of these keys to stepping through the metrics while the record number remains the same. Doing so changes the lower portion of the display to that shown in FIGURE 9-7.

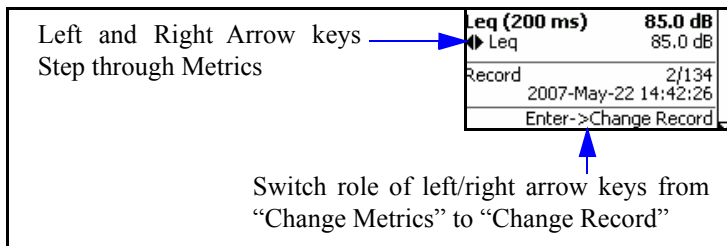



FIGURE 9-7 Left/Right Arrow Change Metrics

When the left/right arrow symbols appear to the left of one of the user-selected metrics, pressing the left or right arrow key backward or forward, through the list of measured metrics, changes the display accordingly.

The text “Enter->Change Record” indicates that pressing  changes the role of these keys to moving the cursor left or right, respectively, selecting a different record to be displayed.

Frequency Spectra

When the LxT is equipped with the optional firmware LXT-OBA and either the 1/1 octave spectra or the 1/3 octave spectra, or both, have been selected for the measurement, the frequency spectra appears in the list of metrics that can be logged.

When frequency spectra have been included in the metrics to be measured in the setup, as described in ‘Time History Setup’ on page 9-3, additional pages display the data.

As shown in FIGURE 9-8, the \leftarrow and \rightarrow keys can be used to either navigate through record numbers, displaying the spectra for each, or to move the cursor in the spectrum displays. Press ENTER to toggle between the roles for these keys.

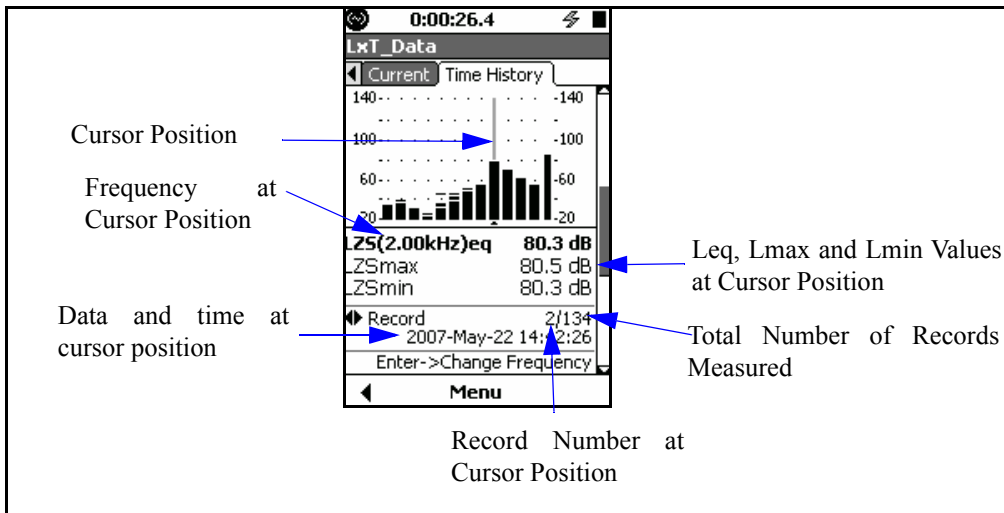

FIGURE 9-8 Time History Display: Spectra Metrics

Link to Measurement History Display

To rapidly switch from a Time History display to a Measurement History display, press the Menu softkey that produces the display shown in FIGURE 9-9.

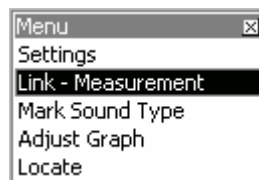

FIGURE 9-9 Link to Measurement History Display

Markers

Markers are used to annotate portions of the time history, especially for the purpose of identifying sound sources as they become dominant in the measurement. The LxT offers ten separate user-definable markers.

Markers Setup

The default values for these parameters are shown in FIGURE 9-10.

Markers are setup using the **Markers** tab, as shown in Figure 9-10.

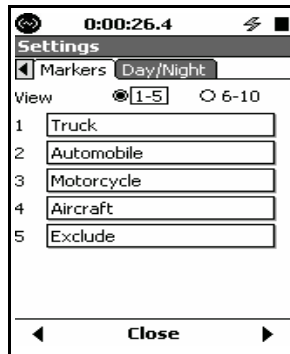

FIGURE 9-10 Markers Setup Window, Markers 1 - 5

There are five markers with names predefined for convenience shown in this figure. Any of these names can be changed by the user.

Markers 6 -10 are shown in Figure 9-11.

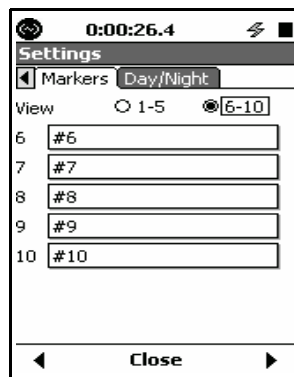

FIGURE 9-11 Markers Setup, Markers 6 - 10

Naming a Marker

The process of naming markers is simplified by using the SLM Utility-G3 or G4 software.

Select the field of the marker to be named and press **ENTER**. This produces a cursor that can be moved left and right to different digit positions in the data field using the **←** and **→** keys, as shown in Figure 9-12.

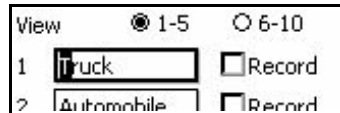

FIGURE 9-12 Marker Name Field

Enter a marker name and press **ENTER** to conclude the process.

Using Markers

The **Time History** tab of the Data Display View is used to display the data, as shown in FIGURE 9-4 “Time History Display: First Point; Keypress” .

After the measurement has started, press the **Menu** key to bring up the display shown in Figure 9-13.

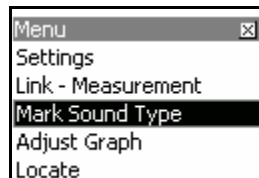

FIGURE 9-13 Menu Options

Highlight **Mark Sound Type** and press **ENTER**, which modifies the Time History display as shown in Figure 9-14.

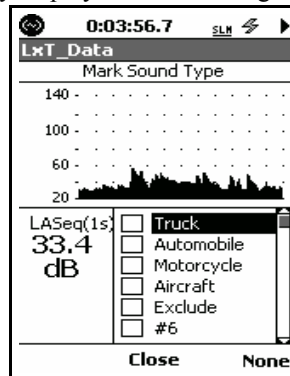

FIGURE 9-14 Time History Display with Markers

Setting Markers On/Off

At any time during a measurement, any of the markers can be set **On** or **Off**. Select the field of the desired marker. Pressing the **Q** key toggles the marker status between **Off** and **On**.

Setting All Markers Off

To set all markers to **Off**, press the right softkey labeled **None**.

Markers Display

A solid horizontal line at the top of the screen indicates when any type of marker has been active during a time history measurement, as shown in "Marker Indication on Time" on page 9-11.

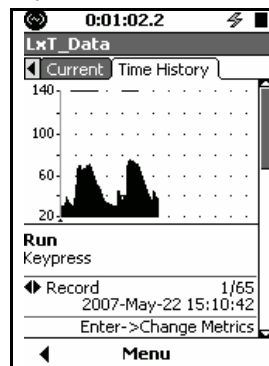

FIGURE 9-15 Marker Indication on Time

The first display, labeled **Run**, represents the keypress initiating the measurement, with the corresponding data and time. There is no measured data associated with this sample point.

Measurement History

This chapter describes Measurement History setup and operation, as well as the data displays associated with the feature. The optional firmware LXT-ENV must be enabled to perform measurement history (Timed Stop and Continuous Run Modes)

Enabling Measurement History

Before beginning to work with measurement history, become familiar with the setup of Run Modes, as described in the chapter entitled “Run Modes.”

You can perform a sequence of measurements either manually or automatically that are stored in a single file.

To enable Measurement History, follow these steps:

- Step 1** Press the Menu softkey.
- Step 2** Select **Settings** and press **ENTER** (ENTER).
- Step 3** Navigate to the **Control** tab.
- Step 4** Press **ENTER** to select the run mode.
- Step 5** Navigate down to the **Enable Measurement History** option and press **ENTER** to select the check box, as shown in FIGURE 10-1.
- Step 6** Depending on the run mode selected, define the measurement time durations, as described in the following section.

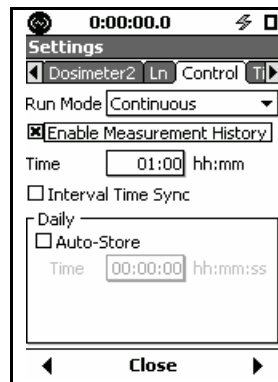

FIGURE 10-1 Measurement History Setup

TABLE 10-1 shows when measurement histories are created for each run mode.

Run Mode	Measurement History Creation
Manual	when Stop is pressed
Timed Stop	when instrument stops
Stop When Stable	when instrument stops
Continuous	at every pre-specified period (1 minute minimum)
Single Block Timer	at every pre-specified period (1 minute minimum)
Daily Timer	at every pre-specified period (1 minute minimum)

TABLE 10-1 Measurement History Creation for Run Modes

Continuous and Timer Modes

For these run modes, when the Measurement History is enabled, a series of measurements are performed and stored automatically, each running for a user-defined time interval. When Measurement History is enabled, the interval time can be specified, as shown in FIGURE 10-3.

FIGURE 10-2

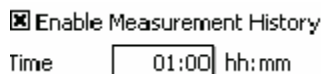

FIGURE 10-3 Measurement Time Menu

Select the **Time** data field and press **ENTER**. Enter the desired time and press **ENTER**.

Interval Time Sync

The interval time sync feature ensures that all measurement records, except the first, begin at a time equal to a multiple of the measurement time selected. For example, if the measurement time is five minutes, and the measurement begins at 08:14:00 (h:m:s format), the first measurement is cut short such that the subsequent measurements begin at 08:15, 08:20, 08:25, etc.

Valid Measurement Times

When other values are selected, the interval time sync still functions, but the time for which the first measurement is cut short is different. See "Timed Stop Mode" below for further detail.

The interval time sync function is intended to be used with the following measurement time values:

- 1, 5, 10, 15, 20 or 30 minutes
- 1 hour



Timed Stop Mode

The Continuous Mode can be used to make an automatic Time History Measurement of a number of records, but the measurement process would need to be stopped manually when the desired number of records have been measured.

The Time Stop Mode with Measurement History has a feature not included for the other run modes: the ability to automatically measure and store a user-defined number of records, then stop. Subsequent runs, each manually initiated, produce the same number of stored measurements.

Data is displayed on the **Measurement History** tab, as described in "Measurement Tab" on page 10-5, and can be saved by pressing the  (STOP) key.

Manual and Stop When Stable Modes

With the Measurement History enabled, sequentially pressing the  and  keys stores the measurement and initiates another measurement, eliminating the need to perform a separate data store operation.

Display of Measurement History

The Data Display includes two tabs to show data measured with the Measurement History; the **Current** tab and the **Measurement** tab.

Measurement Displays

When a measurement is in progress, the data appears on the **Current** tab, as shown in FIGURE 10-4. The first numerical value displayed, L_{ASeq} in this example, is Leq using the frequency weighting and detector from the setup. The second numerical value displayed, L_{AS} in this example, is a user-selected parameter.

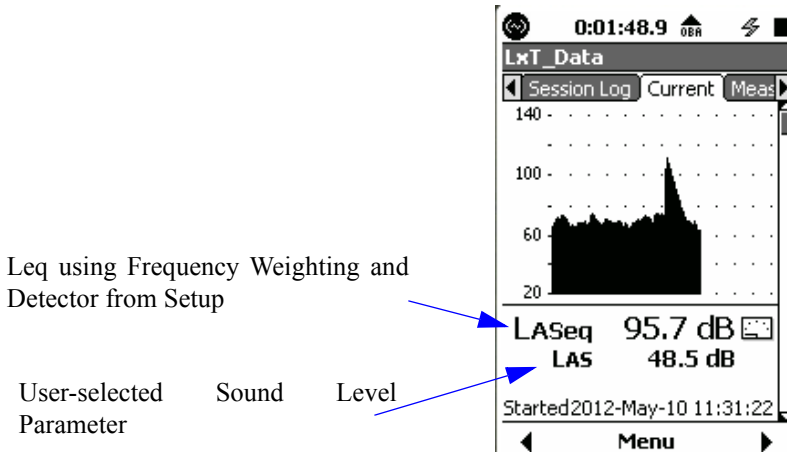

FIGURE 10-4 Measurement in Progress, Current Tab

When the measurement is complete, the data is then available for display on the **Measurement** tab. The **Current** tab is then reset and begins displaying data for the next measurement in progress. As a result, the **Current** tab always displays the measurement in progress.

The **Current** tab can display as many as thirteen different pages, depending on the firmware options enabled and the configured setup. Navigate sequentially through these different pages. With the exception of the first page, these displays are similar to those displayed on the **Measurement** tab, as described in the next section. The main difference is that there is no reference to a record number.

Measurement Tab

During the first measurement, the same data appears on the **Overall** and **Current** tabs. After that, the overall measurement continues while new current measurements are made as the measurement sequence proceeds.

The **Measurement** tab displays data for any of the previously completed measurements. These measurement records are numbered in sequence from the first to the last. The data displayed on the **History** page of the **Measurement** tab is shown in Figure 10-5.

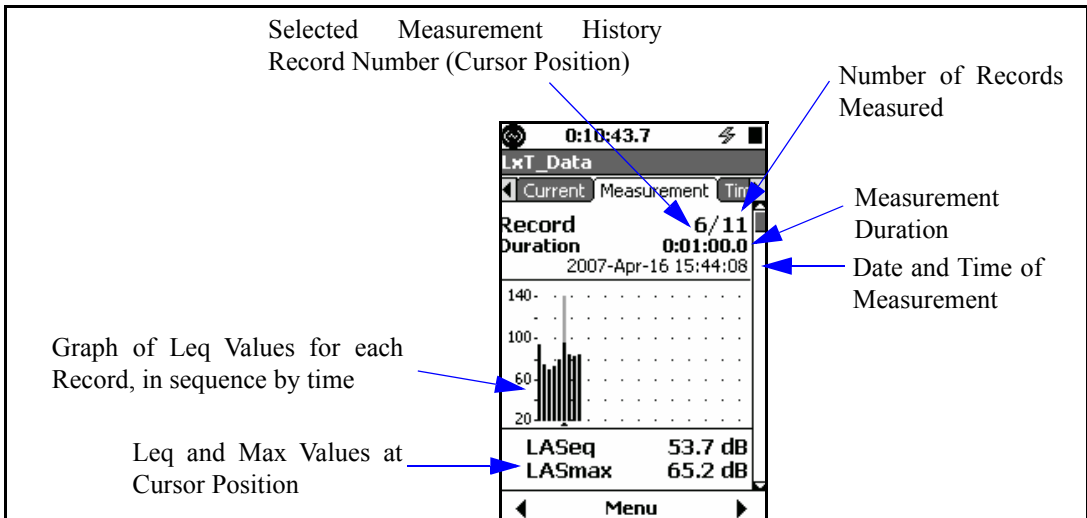

FIGURE 10-5 Measurement Record Display

Selecting and Changing Record Numbers

For all pages of the **Measurement** tab, except the **History** page, the selected record number is indicated below the graph, as shown in FIGURE 10-6.

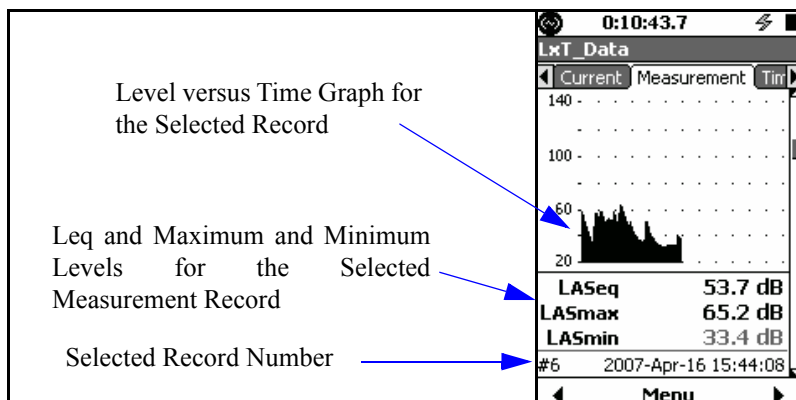

FIGURE 10-6 Profile Page

Depending on firmware options and the configured setup, the **Measurement** tab may include up to 14 tabs. TABLE 10-2 shows **Measurement** tab pages that may appear on your meter. The table includes the page name and an example of how the page may appear.

Page Sequence	Page Name	Example
1	History	
2	Profile	

TABLE 10-2 Measurement Tab Pages

Page Sequence	Page Name	Example
3	Digital	 <p>The screenshot shows the 'LxT Data' interface with the 'Current' measurement tab selected. The main display shows 'LASEq' at 53.7 dB. Below this, it indicates 'LAS > 85.0 dB --- %'. Further down, it lists 'LASmax' as 65.2 dB and 'LASmin' as 33.4 dB. At the bottom, it shows 'Run Time: 0:01:00.0' and a timestamp of '2007-Apr-16 15:44:08'. A 'Menu' button is visible at the very bottom.</p>
4	Leq	 <p>The screenshot shows the 'LxT Data' interface with the 'Current' measurement tab selected. The main display shows 'LASEq' at 53.7 dB and 'LASE' at 71.5 dB. Below this, it lists 'LZpeak' at 96.3 dB and 'LZpeak(max)' at 96.3 dB, with a timestamp of '2007-Apr-16 15:44:47'. It also shows 'LASmax' at 65.2 dB (timestamp: 2007-Apr-16 15:44:32) and 'LASmin' at 33.4 dB (timestamp: 2007-Apr-16 15:44:58). At the bottom, it shows a timestamp of '2007-Apr-16 15:44:08' and a 'Menu' button.</p>
5	1/1 Octave	 <p>The screenshot shows the 'LxT Data' interface with the 'Current' measurement tab selected. The main display features a bar chart showing frequency spectrum data. Below the chart, it lists '1/1 Octave' at 1.00kHz, 'ZSeq' at 51.9 dB, 'ZSmax' at 60.7 dB, and 'ZSmin' at 31.7 dB. At the bottom, it shows a timestamp of '2007-Apr-16 15:44:08' and a 'Menu' button.</p>

TABLE 10-2 Measurement Tab Pages

Page Sequence	Page Name	Example
6	1/3 Octave	
7	Dose 1	
7	Dose 2	

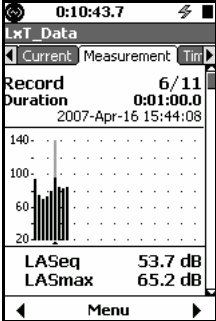
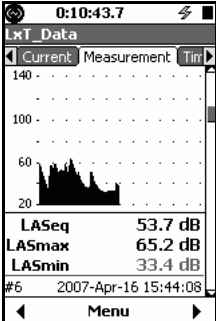
TABLE 10-2 Measurement Tab Pages

Page Sequence	Page Name	Example
9	SEL	 <p>0:10:43.7 LxT_Data Current Measurement Time Sound Exposure Level LASE 71.5 dB Sound Exposure EAS 1.558u Pa²h EA58 748.0u Pa²h EA540 3.740m Pa²h EAS 5.610m Pa²s EA58 2.6927 Pa²s EA540 13.464 Pa²s #6 2007-Apr-16 15:44:08 Menu</p>
10	SEA	 <p>0:00:19.4 LxT_Data Live Overall Session Log C SEA 120.6 dB Frequency Weighting: Z Start Time 19-Aug-2008 14:11:38 End Time 19-Aug-2008 15:40:13 Run Time: 0:00:19.4 Menu</p>
11	Percentiles	 <p>0:10:43.7 LxT_Data Current Measurement Time Ln Percentiles LA5max 65.2 dB LA5 59.7 dB LA510 58.6 dB LA533.3 52.3 dB LA550 45.6 dB LA566.6 38.9 dB LA590 33.9 dB LA5min 33.4 dB #6 2007-Apr-16 15:44:08 Menu</p>

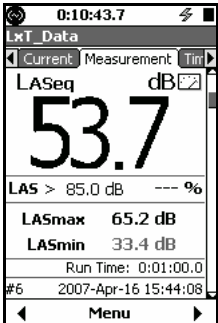
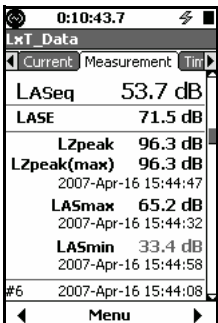
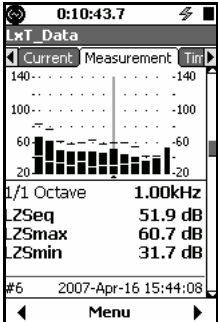
TABLE 10-2 Measurement Tab Pages

Page Sequence	Page Name	Example																																	
12	Exceedances	 <p>The screenshot shows the 'Exceedances' page in the LxT Data application. It lists several measurement criteria with their respective values and durations. All values are 0, indicating no exceedances were detected.</p> <table border="1"> <thead> <tr> <th>Measurement</th> <th>Value</th> <th>Duration</th> </tr> </thead> <tbody> <tr> <td>LA5 > 85.0 dB</td> <td>0</td> <td>0:00:00.0</td> </tr> <tr> <td>LA5 > 115.0 dB</td> <td>0</td> <td>0:00:00.0</td> </tr> <tr> <td>Lzpeak > 135.0 dB</td> <td>0</td> <td>0:00:00.0</td> </tr> <tr> <td>Lzpeak > 137.0 dB</td> <td>0</td> <td>0:00:00.0</td> </tr> <tr> <td>Lzpeak > 140.0 dB</td> <td>0</td> <td>0:00:00.0</td> </tr> </tbody> </table>	Measurement	Value	Duration	LA5 > 85.0 dB	0	0:00:00.0	LA5 > 115.0 dB	0	0:00:00.0	Lzpeak > 135.0 dB	0	0:00:00.0	Lzpeak > 137.0 dB	0	0:00:00.0	Lzpeak > 140.0 dB	0	0:00:00.0															
Measurement	Value	Duration																																	
LA5 > 85.0 dB	0	0:00:00.0																																	
LA5 > 115.0 dB	0	0:00:00.0																																	
Lzpeak > 135.0 dB	0	0:00:00.0																																	
Lzpeak > 137.0 dB	0	0:00:00.0																																	
Lzpeak > 140.0 dB	0	0:00:00.0																																	
13	Overloads	 <p>The screenshot shows the 'Overloads' page in the LxT Data application. It displays overall and DBA (Day-Evening-Night Average) values, all of which are 0.00%. It also shows the duration, run time, and pause time of the measurement.</p> <table border="1"> <thead> <tr> <th>Measurement</th> <th>Value</th> <th>Duration</th> </tr> </thead> <tbody> <tr> <td>Overall</td> <td>0.00%</td> <td>0:00:00.0</td> </tr> <tr> <td>DBA</td> <td>0.00%</td> <td>0:00:00.0</td> </tr> <tr> <td>Duration</td> <td>0:00:08.2</td> <td></td> </tr> <tr> <td>Run Time</td> <td>0:00:08.2</td> <td></td> </tr> <tr> <td>Pause Time</td> <td>0:00:00.0</td> <td></td> </tr> </tbody> </table>	Measurement	Value	Duration	Overall	0.00%	0:00:00.0	DBA	0.00%	0:00:00.0	Duration	0:00:08.2		Run Time	0:00:08.2		Pause Time	0:00:00.0																
Measurement	Value	Duration																																	
Overall	0.00%	0:00:00.0																																	
DBA	0.00%	0:00:00.0																																	
Duration	0:00:08.2																																		
Run Time	0:00:08.2																																		
Pause Time	0:00:00.0																																		
14	Miscellaneous	 <p>The screenshot shows the 'Miscellaneous' page in the LxT Data application. It displays various noise metrics including C minus A, Impulsivity, and their respective durations.</p> <table border="1"> <thead> <tr> <th>Measurement</th> <th>Value</th> <th>Duration</th> </tr> </thead> <tbody> <tr> <td>C minus A</td> <td>60.2 dB</td> <td></td> </tr> <tr> <td>LASeq</td> <td>52.2 dB</td> <td></td> </tr> <tr> <td>LCSeq - LASeq</td> <td>60.2 dB</td> <td></td> </tr> <tr> <td>Impulsivity</td> <td>66.5 dB</td> <td></td> </tr> <tr> <td>LA1eq</td> <td>52.2 dB</td> <td></td> </tr> <tr> <td>LAeq</td> <td>52.2 dB</td> <td></td> </tr> <tr> <td>LA1eq-LAeq</td> <td>14.3 dB</td> <td></td> </tr> <tr> <td>Duration</td> <td>0:00:08.2</td> <td></td> </tr> <tr> <td>Run Time</td> <td>0:00:08.2</td> <td></td> </tr> <tr> <td>Pause Time</td> <td>0:00:00.0</td> <td></td> </tr> </tbody> </table>	Measurement	Value	Duration	C minus A	60.2 dB		LASeq	52.2 dB		LCSeq - LASeq	60.2 dB		Impulsivity	66.5 dB		LA1eq	52.2 dB		LAeq	52.2 dB		LA1eq-LAeq	14.3 dB		Duration	0:00:08.2		Run Time	0:00:08.2		Pause Time	0:00:00.0	
Measurement	Value	Duration																																	
C minus A	60.2 dB																																		
LASeq	52.2 dB																																		
LCSeq - LASeq	60.2 dB																																		
Impulsivity	66.5 dB																																		
LA1eq	52.2 dB																																		
LAeq	52.2 dB																																		
LA1eq-LAeq	14.3 dB																																		
Duration	0:00:08.2																																		
Run Time	0:00:08.2																																		
Pause Time	0:00:00.0																																		

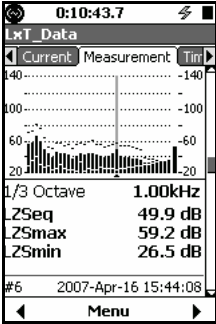
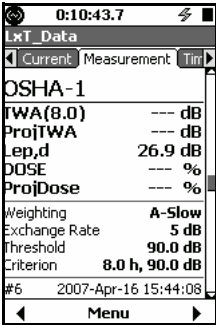
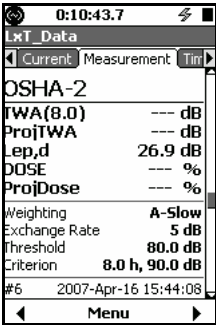
TABLE 10-2 Measurement Tab Pages

There is no cursor on the Profile graph, nor a numerical display of amplitude or time.

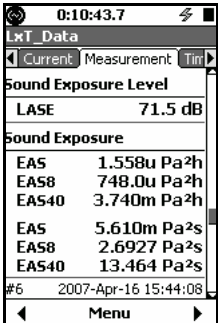
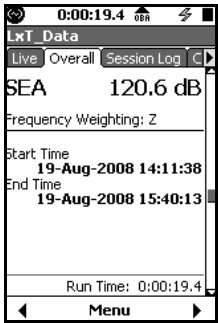
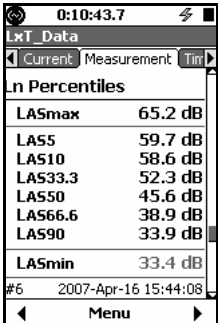
Non-Spectra Displays

With the exception of frequency spectra displays, the $\left\{ \right\}$ and $\left\} \right\}$ keys are used to step the selected measurement record number up or down, respectively.

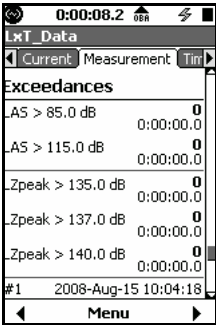
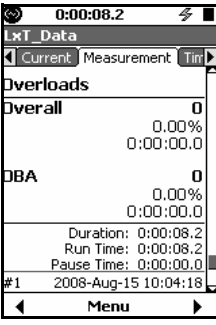
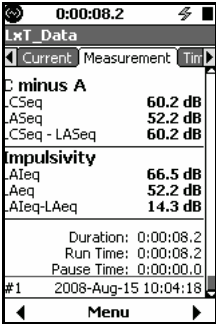
Frequency Spectra Displays

When a frequency spectrum is displayed, you can navigate to the right or left so that the levels can be displayed for different frequency bands. To change the displayed record, shift to a non-spectrum display to make the change, then return to the frequency spectrum display.

Link to Time History

*Time History must be enabled before linking to the **Time History** tab from measurement history pages.*

To link data from the **Measurement** tab to the **Time History** tab, press the Menu softkey and select **Link-Time History**, as shown in FIGURE 10-7. When Time History is also enabled, you can make a rapid transition from any of the measurement history pages to the **Time History** tab.

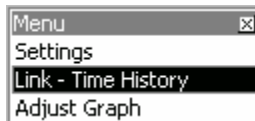

FIGURE 10-7 Link to Time History

The **Link-Time History** selection displays the **Time History** page on the **Time History** tab, as shown in FIGURE 10-8.

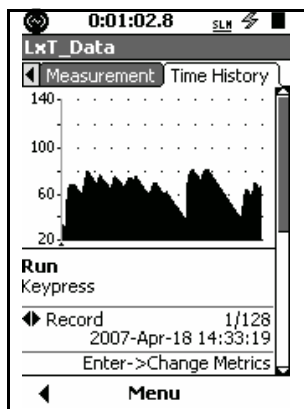



FIGURE 10-8 Time History Tab

Data Explorer

This chapter describes how to view the stored data files in the SoundTrack LxT[®] and SoundExpert[®] LxT Data Explorer.

Control Panel - Data Explorer

To display the Data Explorer Page, press the  (TOOLS) key. Select the **Data Explorer** icon as shown in FIGURE 11-1.

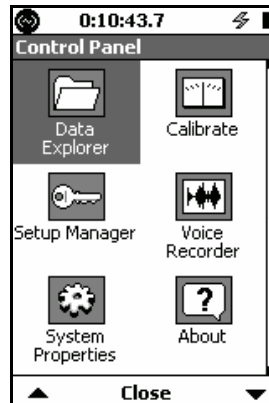



FIGURE 11-1 Control Panel

Press  (ENTER) to open the Data Explorer Page.

Data Explorer is a directory of all the stored data files. Up to nine data files are displayed at one time, so there may be more data files in the directory than are displayed in the first view. All files may be viewed by navigating through the list and pressing .

Data Explorer consists of just one page, the **Data Explorer** page, as shown in FIGURE 11-2.

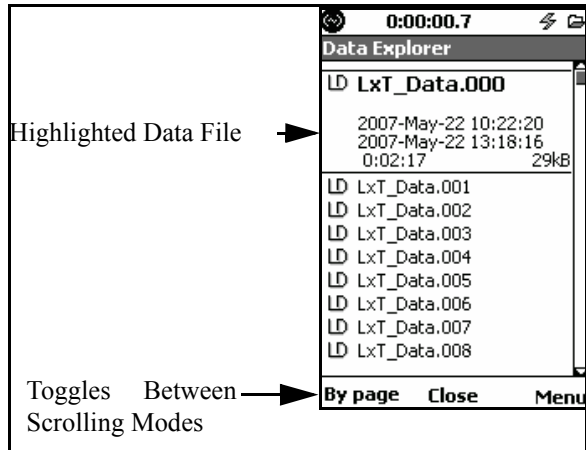

FIGURE 11-2 Data Explorer

Navigational Scrolling Modes

There are two navigational scrolling modes:

- **By item (default mode):** pressing the up or down arrow key moves to previous or next data files in sequence.
- **By page:** pressing the up or down arrow key moves the to the first or last data file displayed on pages.

Press the left softkey, labeled **By page**, to toggle between modes, as shown in FIGURE 11-2. Because the softkey is the toggle, the mode displayed on the meter is not the active mode.

Menu Softkey

You can press the **Menu** softkey to view more options, as shown in FIGURE 11-3. This section describes the options on the menu.



FIGURE 11-3 Data Explorer Menu

To leave this menu without selecting an option, press the **Close Softkey**.

View

View opens the selected file to see its contents.

Delete

Delete causes a message box to appear asking you to confirm the request, as shown in FIGURE 11-4.



FIGURE 11-4 Delete File

Press **ENTER** to delete or select **No** and press **ENTER**.

Delete All

Delete All deletes all the stored data files.

Rename

The **Rename** option enables you to change the name of the selected data file. Pressing **ENTER** brings up a message box for editing the file name, as shown in FIGURE 11-5.

Filenames must be in the short filename (SFN) format, or 8.3 filename format.

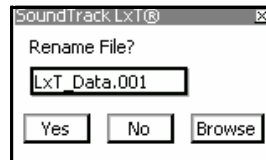

FIGURE 11-5 Rename File

If your new file name is the same as a file already in the directory, an overwrite message prompt appears, as shown in FIGURE 11-7. If you select **Yes**, the old file is over-written with the newly named file. A response of **No** returns the **Rename File** message prompt.

Overwrite an Existing File

You can also overwrite a stored file. In the **Rename File** prompt, select the Browse button and press **ENTER** to display a list of file names, as shown in FIGURE 11-6.

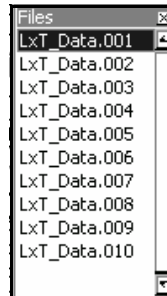

FIGURE 11-6 File Name List

Select a name from the list and press **ENTER**. The **Rename File** prompt opens again, with the name of the file that is to be overwritten in the file name field.

Select **Yes** and press **ENTER** to display the Overwrite Confirmation menu, as shown in FIGURE 11-7.

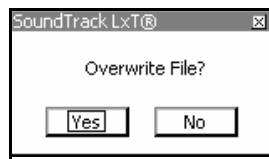

FIGURE 11-7 Overwrite Confirmation

Select the desired option and press **ENTER**. If you select **Yes**, the old file is over-written with the selected file. Selecting **No** returns the **Rename File** prompt.

Refresh List

Refresh List refreshes the file list on the **Data Explorer** Page.

Load Settings

Load Settings copies the measurement settings from the file to the active settings. This is an easy way to make another measurement using identical settings.

Jump to Beginning

The **Jump to Beginning** option selects the first data file listed.

Jump to End

The **Jump to End** option selects the last data file listed

System Properties

This chapter describes the System Properties tabs, which you can use to identify or control functions of the sound level meter not related to sound measurement or calculations.

Control Panel - System Properties

To activate the System Properties tabs, press the  (TOOLS) key. Navigate to select the System Properties icon as shown in FIGURE 12-1.

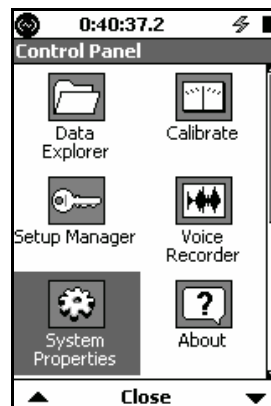

FIGURE 12-1 Control Panel

Device

It is easier to enter the text information for these three fields using the Blaze software or the SLM Utility-G3 or G4 software.

The **Device** tab displays three fields in which the user may enter information about the instrument, as shown in Figure 12-2. This can identify the owners company name and address.

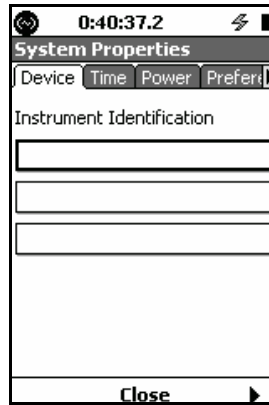

FIGURE 12-2 Device Tab

Select and edit one of the three fields. Press **ENTER** (ENTER) to highlight the 1st character position in the field. Use the **←**, **→**, **⏪** and **⏩** keys to scroll through a list of characters and change character positions in the field. When the information is complete, press **ENTER** to accept the information. Select another field, if desired, and repeat the character selection process.

Time

Use the **Time** tab to specify the time and date for the LxT, as shown in Figure 12-3.

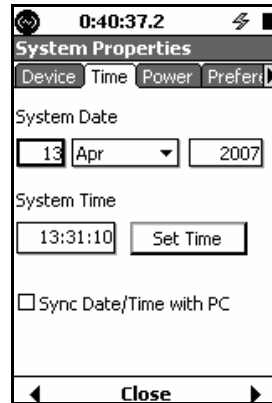

FIGURE 12-3 Time Tab

Setting Day and Year

Navigate to select the **Day** and **Year** fields for **System Date**. Press **ENTER** to select the 1st character position. Use the **←**, **→**, **⏪** and **⏩** keys to change the values. Press **ENTER** to select the desired value.

Selecting the Month

Navigate to the Month menu and press **ENTER** to open it. Select a month and press **ENTER**, as shown in FIGURE 12-4.

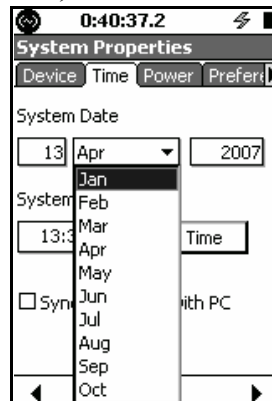

FIGURE 12-4 Month List

Setting the Time

Navigate to the **System Time** field and specify the time for the meter in the same manner used for setting the Day and Year. Navigate to the **Set Time** button and press **ENTER**.

Sync Data/Time with PC

Selecting the **Sync Date/Time with PC** check box enables the LxT time to be set to the PC time when the unit is connected to the SLM Utility-G3 or G4 software. Select the check box and press **ENTER** to turn this option on or off.

Power

The **Power** tab contains options for managing how power is used by the sound level meter, as shown in Figure 12-5.

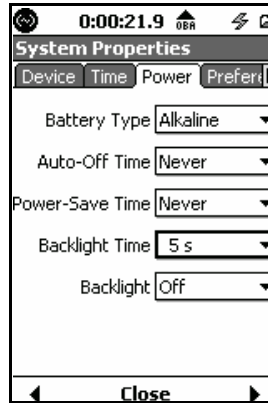

FIGURE 12-5 Power Tab

To specify settings on the **Power** tab, navigate and select values as discussed in previous sections.

Battery Type

Battery type information is used for calculating battery life. To set the battery type, select the **Battery Type** menu and press **ENTER** to open it, as shown in FIGURE 12-6.



FIGURE 12-6 Battery Type Menu

Do not use 3.8 Volt Lithium batteries; they will blow the fuse.

Select the desired time and press **ENTER**.

The default is **Alkaline**.

WARNING:Do not mix Alkaline and NiMH batteries.

WARNING:Do not mix batteries from different manufacturers

WARNING:Replace all four batteries when installing fresh cells

WARNING:The correct battery type must be specified based on the battery type installed.

Auto-Off Time

Auto-Off time is the duration of time the instrument stays on when no activity is occurring, such as key presses, running a measurement, USB communications, etc.

Pressing the **ON / OFF** key returns the instrument and the displays the state it was in when the Auto-Off time expired.

The auto-off feature is ignored when the unit is connected to USB power. The feature is not ignored when it is connected to external power (12 Vdc).

To set the Auto-off Time, select the **Auto-Off Time** menu and press **ENTER** to open it, as shown in FIGURE 12-7.

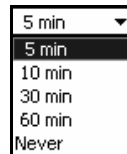

FIGURE 12-7 Auto-Off Time Menu

Select the desired time and press **ENTER**.

The default is **Never**.

Power-Save Time

In the power save mode, battery power is significantly reduced by shutting down the display and analog circuitry and ceasing signal processing activities.

There are two power saving features controlled by the Power-Save Time setting. Power can be shut off to the

display and to the analog circuitry to save power when the Power-Save Time is set to a value other than **Never**.

The display is powered down when no keys on the instrument have been pressed for the time set. Pressing any key reactivates the display.

The analog circuitry, including power to the preamplifier, shuts down when the instrument is stopped for the time set. Pressing the  (RUN / PAUSE) key, or execution of an automatic timer, restores power to the analog circuitry and the instrument can take data in a number of seconds.

To set the Power-Save Time, select the **Power-Save Time** field and press  to open the Power-Save Time Menu, as shown in FIGURE 12-8.

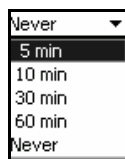



FIGURE 12-8 Power-Save Time Menu

Select the desired time and press .

The default is **Never**.

Power Save Icon



When the LxT is in the power save mode, the power save icon



is displayed in the location where the measurement status icons, described in "Measurement Status", usually appear.

Exit from Power Save Mode

Press any of the following keys to exit from the power save mode:

-  (STOP/STORE)
-  (RESET)
-  (RUN / PAUSE): There is a short delay before the instrument starts recording data.

The following actions also cause an exit from the power save mode:

- Calibration
- Recording (voice or sound recording)
- Playing (voice or sound recording)

Backlight Time

The **Backlight Time** field sets the duration of time the backlight remains on after the last key press.

To set the time, select the field and press the  to open the Backlight Time Menu, as shown in FIGURE 12-9.

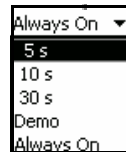



FIGURE 12-9 Backlight Time Menu

Select the desired time and press .

The default is **10 s**.

Backlight

*Using the backlight on **Bright** significantly increases power consumption and decreases battery life.*

The **Backlight** field sets the intensity of the backlight. To set it, select the field and press **ENTER** to open the Backlight Menu, as shown in FIGURE 12-10.



FIGURE 12-10 Backlight Menu

Select the desired time and press **ENTER**.

The default is **Off**.

Several situations affect the backlight and its intensity, as follows:

- When the USB Host port is turned on, the backlight turns off for five seconds.
- When the USB Host port is on, the backlight cannot be set to the **Bright** intensity (if set to **Bright**, it switches to the **Dim** intensity).
- When running on batteries that have less than 10% charge, the backlight cannot be set to the **Bright** intensity (if set to **Bright**, it switches to the **Dim** intensity).

When running on batteries that have less than 3% charge, the backlight is not permitted to turn on.

Preferences

The **Preferences** tab is used to select general instrument formatting.

FIGURE 12-11 shows the **Preferences** tab.

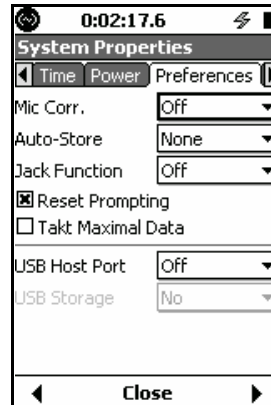

FIGURE 12-11 Preferences Tab

To change the fields on the **Preferences** tab, navigate and select values as described in previous sections.

Microphone Correction

When using a free-field microphone, a correction can be applied to provide a random incidence response or, when using a random incidence microphone, a correction can be applied to provide a free-field response. Highlight the **Mic Corr.** field and press **ENTER** to open the Microphone Correction menu, as shown in FIGURE 12-12.

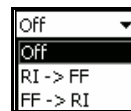

FIGURE 12-12 Microphone Correction Menu

To correct a random incidence microphone to obtain a free-field response, select **RI -> FF** and press **ENTER**.

To correct a free-field microphone to obtain a random incidence response, select **FF -> RI** and press **ENTER**.

The default mode is **Off**.

Auto-Store

The LxT provides three Auto-Store options to enhance your data gathering activities:

- None
- Prompt
- Store

To set the Auto-Store preference, select the field and press , as shown in FIGURE 12-13.

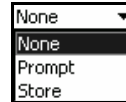



FIGURE 12-13 Auto-Store Preferences



Select the desired setting and press .

None

Press the  key to stop the measurement. Press it again to store the data and also assign a filename. For more information, see “Storing Measurements”.

Prompt

*When the **Prompt** preference is selected and the Run Mode is set to **Timed Stop** or **Daily Timer**, the LxT neither prompts nor automatically stores the data.*

When the  key is pressed to stop a measurement, you are prompted to save a data file. If you select **Yes**, the data file is saved. If **No** is selected, the data file is not saved. If data is stored when the  key is pressed, the instrument is automatically reset so a new measurement may begin.

Store

*Note: When the **Store** preference is selected and the Run Mode is set to **Timed Stop** or **Daily Timer**, the LxT neither prompts nor automatically stores the data.*

In this mode, when the  key is pressed, a data file is automatically saved. The default file name is assigned to the file. There is no user interaction in this process.

Pressing the  key automatically resets the instrument so a new measurement may begin.

Table 12-1 shows how manual or timer-based stops affect Auto-Store preferences in various run modes.

Run Mode	Type of Stop	Auto-Store Preference	
		Prompt	Store
Timed Stop	Timer-activated final stop	Prompts when timer is complete	File automatically stored
	Manually-activated (stop key)	No action performed	No action performed
Stop When Stable	Timer-activated stop	Prompts when stable	File automatically stored
	Manually-activated (stop key)	Prompts when stopped	File automatically stored
Single Block Timer	Timer-activated stop	Prompts when timer complete	File automatically stored
	Manually-activated (stop key)	Prompts when stopped	File automatically stored
Daily Timer	Timer-activated final stop	No prompt; file automatically stored	File automatically stored
	Manually-activated (stop key)	No action performed	No action performed

Table 12-1 Auto-Store Preference Configurations

Jack Function

The AC/DC Out/Headset Jack on the bottom of the instrument can be configured to provide one of the following:

- As an AC/DC output of the signal from the detector. Use with the optional AC/DC Output Cable (CLBL139); AC signal is output via the red BNC, and DC signal via the white BNC. The AC output is typically directed to a frequency analyzer or oscilloscope and the DC output is typically directed to a strip chart recorder.
- As a microphone and speaker connection when used with the optional headset for voice recording/playback (ACC003)

It can also be set to **Off**.

The jack function setting becomes active as soon as it is selected.

To set the Jack Function preference, select the field and press **ENTER**, as shown in FIGURE 12-14.

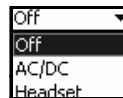

FIGURE 12-14 Jack Function Preferences

Select the desired Jack function setting and press **ENTER**.

Reset Prompting

If the Reset Prompting check box is selected, you are prompted with an “Are You Sure” message box whenever the **RESET** key is pressed. If it is not selected, the prompt does not appear prior to the reset action taking place.

Navigate to select the **Reset Prompting** check box. Press **ENTER** to select the check box or deselect it.

Takt Maximal Data

When this option is checked, the parameter LAFTMS is also measured and displayed on the Community Noise section of the Overall Screen and as a parameter of a Time History measurement.

USB Host Port

The USB Host Port must be **On** to utilize the USB Port with peripheral devices.

This function controls power to the USB Port, so it must be set to **On** in order to utilize it with peripheral devices. To turn on the USB Host Port, select the field and press **ENTER**, as shown in FIGURE 12-15.

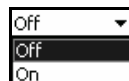

FIGURE 12-15 USB Host Port On/Off Menu

Select the desired USB Host Port Status and press **ENTER**.

USB Storage

Data can be stored to internal memory or to an external memory device connected to the USB Port. The options are:

- **No:** Store only to internal memory

- **Auto:** Store data to USB memory if available; otherwise, store to internal memory.

Select the USB Storage field and press **ENTER**, as shown in FIGURE 12-16.

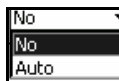

FIGURE 12-16 USB Storage Preferences

Select the desired USB Storage and press **ENTER**.

When data is stored to USB memory, it is first stored to internal flash memory, a process which is much faster than storing directly to USB memory. Next, the data is copied to USB memory without interfering with the operation of the instrument. When the data file has been successfully copied, the original data file in internal memory is deleted.

USB Serial Printer (PRN003)

It is possible to print an Overall Summary and a screenshot of the LxT screen using a USB Serial Printer (MCP8770). To do this, plug the USB printer into the USB port and turn it on. Then, turn on the USB Port as described in “USB Host Port” on page 12-12. This adds two items to the Menu display, as shown in FIGURE 12-17 and FIGURE 12-18.

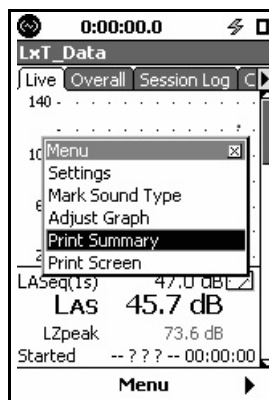

FIGURE 12-17 Print Summary Menu Item

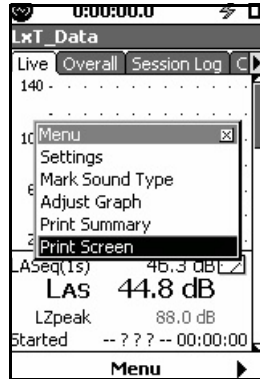

FIGURE 12-18 Print Screen Menu Item

Selecting either option and pressing **ENTER** initiates the corresponding printing action. When the print is successfully completed, the message shown in FIGURE 12-19 appears.



FIGURE 12-19 Print Complete Message

Print Error Messages

Printing without connecting the printer, or with the printer off, results in the message shown in FIGURE 12-20.



FIGURE 12-20 Printer Not Present Message

If the printer is disconnected during the printing process, the message shown in FIGURE 12-21 appears.



FIGURE 12-21 Printer Disconnected Message

Localization

The default values for the **Localization** tab are shown in FIGURE 12-22.

The **Localization** tab contains display options for values that may vary from one country or region to another, as shown in FIGURE 12-22.

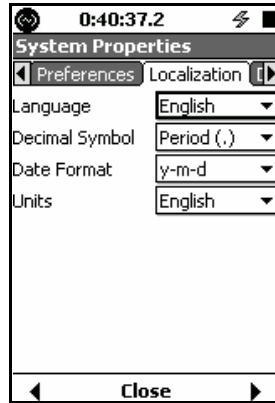

FIGURE 12-22 Localization Tab

To change the fields on the **Localization** tab, navigate and select values as discussed in previous sections.

Languages

The LxT supports the following languages:

- English
- French
- German
- Italian
- Portuguese (Portugal)
- Spanish
- Swedish
- Norwegian
- Portuguese (Brazil)

English is the default language.

Select the Language field and press **ENTER**, as shown in FIGURE 12-23.



FIGURE 12-23 Language Preferences

Select the desired language and press **ENTER**.

Decimal Symbol

The LxT supports two formats for the decimal symbol:

- Period (.)
- Comma (,)

Select the Decimal Symbol field and press **ENTER**, as shown FIGURE 12-24.

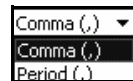

FIGURE 12-24 Decimal Symbol Preferences

Select the desired symbol and press **ENTER**.

Date Format

The LxT supports two formats for expressing dates:

- day-month-year
- year-month-day

Select the Date Format field and press **ENTER**, as shown in FIGURE 12-25.

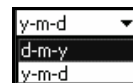

FIGURE 12-25 Date Format Preferences

Select the desired Date Format and press **ENTER**.

Units

The LxT supports both English and SI units.

Select the **Units** field and press **ENTER**, as shown in FIGURE 12-26.

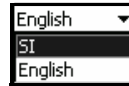

FIGURE 12-26 Units Menu

Select the desired units and press **ENTER**.

Displays

*The default values for the **Displays** tab are shown in FIGURE 12-27.*

The **Displays** tab contains options for customization of the displays, as shown in FIGURE 12-27.

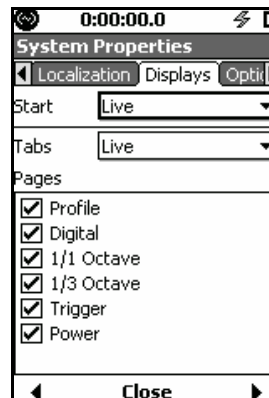

FIGURE 12-27 Displays Tab

Start

The **Start** field lists the displays that can be shown when the LxT is first turned on.

Select the **Start** field and press **ENTER**, as shown in FIGURE 12-28



FIGURE 12-28 Display Start Options

Select the desired Start display and press **ENTER**.

Selecting Displays to Appear

When there are measurement functions not being used or data displays which are not of interest for a measurement, the instrument operation can be streamlined by hiding selected displays. As a default, all available displays are set to appear.

Tab Display Selection

Use the **⇧** key to select the list of tabs that can appear or be hidden, as shown in FIGURE 12-29.



FIGURE 12-29 Display Tab Options

Select the desired tab displays and press **ENTER**.

Display Selection

The displays that can be set to appear or be hidden are shown below for each of the possible tab selections.

Live Tab Displays (6)



FIGURE 12-30 Live Tab Displays

Overall Tab Displays (15)

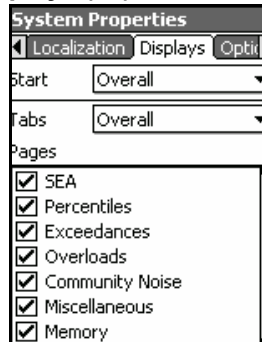

FIGURE 12-31 Overall Tab Displays

Session Log Display

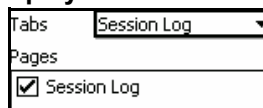
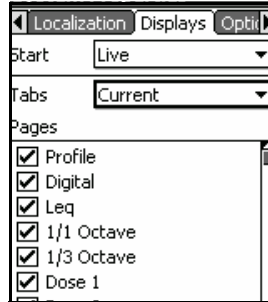
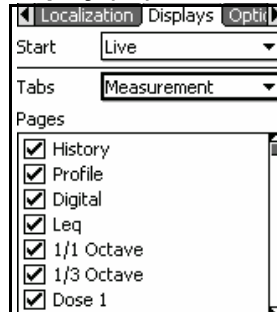

FIGURE 12-32 Session Log Displays

Current Display (14)



Measurement Display (13)



Time History Displays (5)

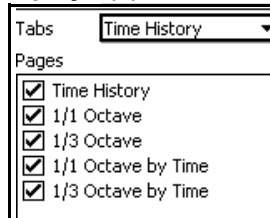

FIGURE 12-33 Time History Tab Displays

All checked displays appear on the LxT.

To modify any of the displays associated with one of the tabs, select the field listing those displays and press **ENTER** to obtain the display shown in FIGURE 12-34.

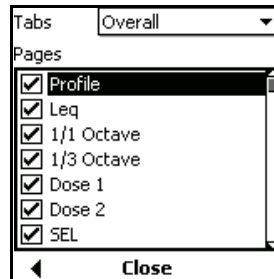

FIGURE 12-34 Display; Set to Appear or Hide

Pressing the **↵** key toggles the state of the highlighted display between **Appear** (checked) and **Hide** (unchecked).

Use the **⏪** and **⏩** keys to highlight different displays and set them as desired. When finished setting the display types for this tab, press **ENTER**.

When all desired modifications have been made to the displays for all tabs, press the center softkey **Close** to return to the Control Panel.

Options

Some default options, such as Industrial Hygiene, do not appear in the list as they cannot be masked.

The **Options** tab, shown in FIGURE 12-35, permits the user to enable/disable installed options on the LxT.

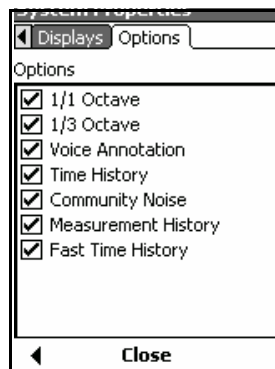





FIGURE 12-35 Options Tab

Note that this is temporary and does not result in permanent loss of a purchased option. You can re-enable a purchased option at any time, as described in “Format & Restore Defaults” on page 15-3.

When the option is checked in mask, it is enabled in the instrument. Unchecking removes the option. To mask or unmask any option(s), press **ENTER** to enter the dialog mode. Use the  and  arrow keys to highlight each option and use  and **ENTER** to toggle the state of the option between masked (unchecked) and unmasked (checked). In FIGURE 12-36, the Voice Annotation option has been masked.

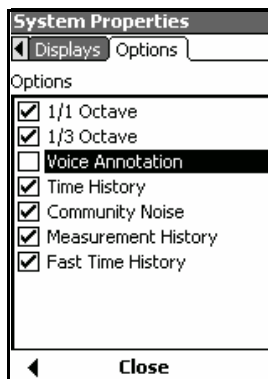

FIGURE 12-36 Sound Recorder Masked

When all selections have been made, press **ENTER** to exit the dialog mode and press **Close**, which produces the message shown in FIGURE 12-37.

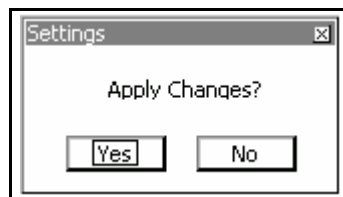

FIGURE 12-37 Apply Changes



Select **Yes** and press , which produces the message shown in FIGURE 12-38, indicating that the instrument must be rebooted for the masking/unmasking changes to take effect.



FIGURE 12-38 Reminder to Reboot Instrument

Press  to return to the System Properties Menu and reboot the instrument.

Lock/Unlock the LxT

To prevent unauthorized use or tampering with measurements and data, the LxT provides a lock feature. When this is enabled, the LxT is tamper proof to one of four user-selectable levels of security.

Control Panel - Lock



To activate the Lock dialog, press the  (TOOLS) key. Navigate to select the Lock icon, as shown in FIGURE 13-1.



FIGURE 13-1 Control Panel

Press  (ENTER) to open the Lock display.

Select the Lock Mode list box. Press **ENTER** to expand the drop down list, as shown in FIGURE 13-2.



FIGURE 13-2 Lock Mode List

Select the desired lock mode. Press **ENTER** to accept the selection.

Lock Modes

Unlocked

The user has complete access to the features of the instrument.

Lock w/Auto-Store

The user cannot change the data view in this mode. Only the status line at the top of the screen is updated. A measurement may be running when this mode is enabled. Pressing the **RUN/PAUSE** key begins a measurement. A measurement cannot be paused. Pressing the **STOP/STORE** key stops the run and stores the data but does not reset the measurement. See Chapter 13 "Locked With Auto-Store" on page 13-5.

Lock w/Manual Store

In this mode, the Auto-Store preference is disabled, see "Preferences" on page 12-8.

You cannot change the data view in this mode. Only the status line at the top of the screen is updated. Measurements may be run, paused and stopped. See Chapter 13 "Locked With Manual-Store" on page 13-7.

Fully Locked

The user has no access to the instrument, except to start a run. Auto-Store preferences are enabled in this mode. See Chapter 13 "Fully Locked" on page 13-4.

A measurement cannot be reset when the Model LxT is locked in any mode.

Unlock Code

Navigate to the Unlock Code field and press **ENTER** to select it, as shown in FIGURE 13-3.

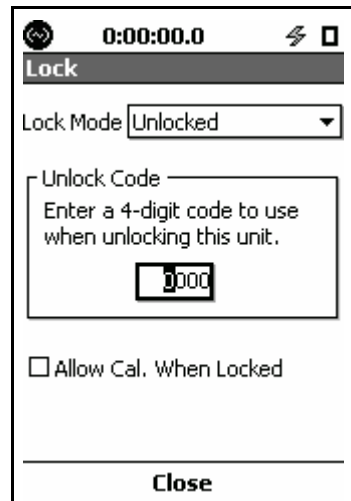

FIGURE 13-3 Unlock Code

Press **ENTER**. The first character in the field are highlighted. Use the **←** and **→** keys to increment to decrement the selected number and use the **⏪** and **⏩** move between numbers in the code. Continue your number selections until the unlock code has been entered; then, press **ENTER**.

Allow Calibration When Locked

Select **Allow Cal. When Locked**. Press **ENTER** to toggle the state of the check boxes shown in FIGURE 13-4. If the box is checked, calibration is allowed while the unit is locked and not running.

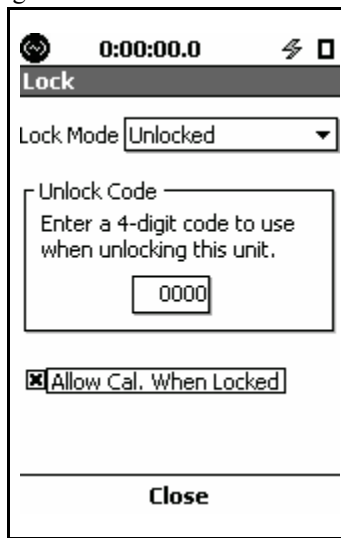



FIGURE 13-4 Allow Calibration When Locked

Fully Locked

When the LxT is fully locked, the display appears as shown in FIGURE 13-5. It is possible to select the Fully Locked mode while a measurement is in progress.



FIGURE 13-5 Fully Locked

Also, while fully locked, pressing the  (RUN/PAUSE) key starts a measurement with the message box shown in FIGURE 13-6.

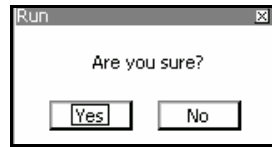

FIGURE 13-6 Measurement While Locked Message

Selecting **Yes** begins the measurement. A measurement cannot be paused, stopped or stored in the Fully Locked mode.

Locked With Auto-Store

If the Locked w/Auto-Store mode has been selected, upon accepting the changes on the Lock display, the screen appears as shown in FIGURE 13-7.

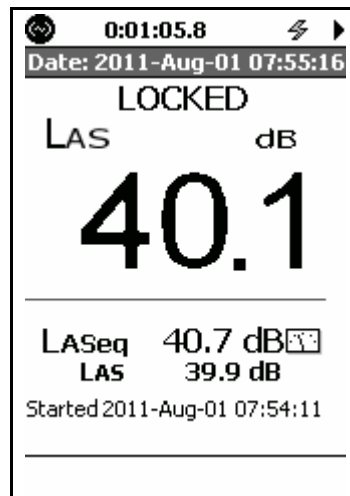



FIGURE 13-7 Locked with Auto Store or Manual Store

In this mode, measurements may be started by pressing the  key. A measurement may not be paused or stopped.

Pressing the  key initiates storing the data file, as shown in Figure 13-8.

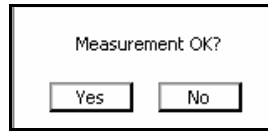





FIGURE 13-8 Auto-Store-Stop

If **Yes** is selected, the data file is saved. The unit is still locked and a new measurement may be started by pressing the  key. If **No** is selected, the data is reset and a new measurement can be made.

Unlocking the LxT

To unlock the LxT, press the  key, and . Or, press the right or left Soft-key to bring up the Unlock dialog box shown in FIGURE 13-9. Enter the digits to unlock code and press .

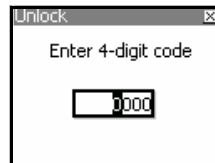





FIGURE 13-9 Unlock

Once the LxT is successfully unlocked, access is restored to all areas.

Locked With Manual-Store

If you select the Locked w/Manual-Store mode, measurements are started by pressing the  key. Pressing the  key a second time pauses the measurement and pressing it again continues the measurement.

The  key stops a measurement and pressing it a second time initiates the storage process by displaying the “Save File” prompt, as shown in FIGURE 13-10.

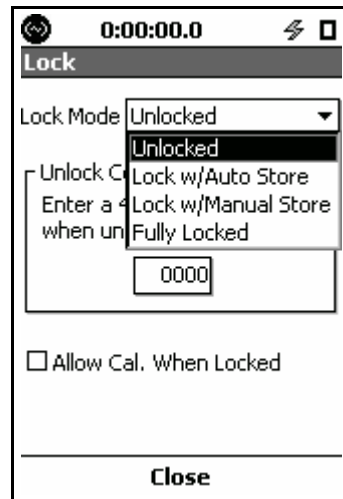

FIGURE 13-10 Manual Store When Locked

Select **Yes** to store the file number indicated, **No** to abort the storage operation, or **Browse** to overwrite a file into which data has already been stored.

Calibration When The LxT Is Locked

When the LxT is in any of the locked modes, and is stopped, the unit may be calibrated. This is only possible if the “Allow Cal. When Locked” check box, on the Lock display, is checked previous to entering Lock mode. See FIGURE 13-4.

If the Center Softkey indicating **CAL** is active, as shown in FIGURE 13-11, press this key. This displays the calibration screen. See “Calibration” for complete details on calibrating the LxT.



FIGURE 13-11 Locked with Calibration Permitted

About

The **About** tabs summarize information about the instrument.

Control Panel - About

To activate the About tabs, press the  (TOOLS) key and navigate to the About icon, as shown in FIGURE 14-1.

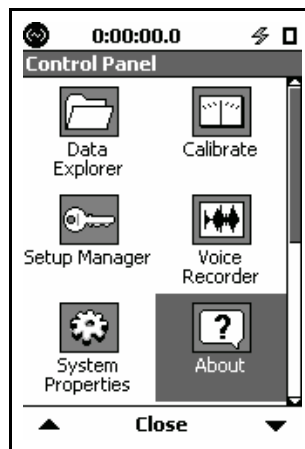

FIGURE 14-1 Control Panel

About Tab

The **About** tab displays important information about the instrument such as Serial Number and Firmware Revision number.

FIGURE 14-2 shows the **About** tab.



FIGURE 14-2 About Tab

Standards

The **Standards** tab shown in FIGURE 14-3 lists standards met by the LxT. For more information on the technical standards for the LxT, refer to the section "Standards Met by LxT".

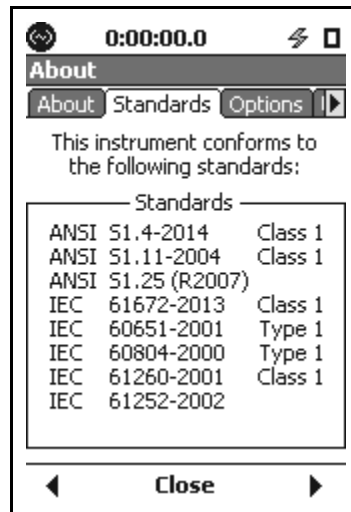

FIGURE 14-3 Standards Tab

Options

Options may be added at any time. To purchase additional options, contact your local representative, found at www.larsondavis.com/sales.

The **Options** tab shown in FIGURE 14-4 lists the options available for the LxT. Installed options have a check mark next to them.

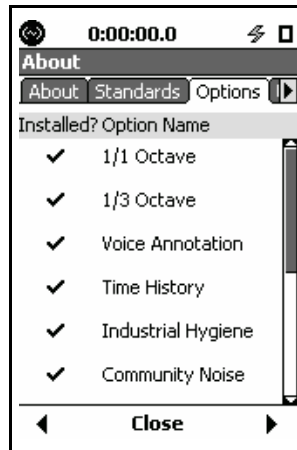

FIGURE 14-4 Options Tab

User

The **User** tab displays identifying information associated with the LxT. You can enter instrument identification information on the **Device** tab of System Properties or by entering it in utility or host software.

FIGURE 14-5 shows the **User** tab.

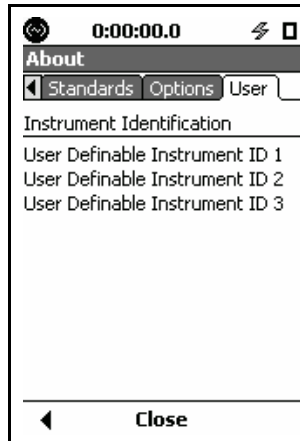



FIGURE 14-5 User Tab

System Utilities

This chapter describes the system utilities for the LxT.

System Utilities

Press the  key one time in order to see the **System Utilities** icon on the Control Panel.







To activate the System Utilities, press the  (TOOLS) key. Use the , ,  or  keys to select the **System Utilities** icon as shown in Figure 15-1.



FIGURE 15-1 Control Panel

Press  (ENTER) to open the System Utilities.

There is only one tab in the System Utilities: **File System**.

File System

The **File System** tab is used to repair or recover from file system problems. The functions available on this page are similar to functions that would be used to manage a hard drive. See Figure 15-2.

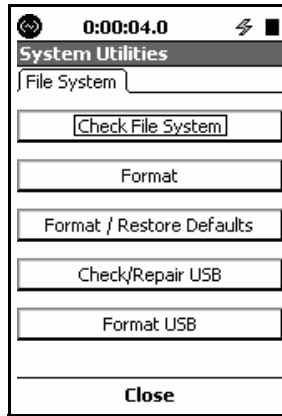

FIGURE 15-2 File System

The functions on the File System page are as follows:

- Check File System
- Format
- Format & Restore Defaults
- Check/Repair USB
- Format USB

Select the desired function and press **ENTER** to initiate the operation.

Warning: Using these functions may cause loss of data and restoration of the LxT to default conditions.

You should only activate these functions if there appears to be a problem.

Check File System

These utilities detect and repair file system problems.

When the Check File System button is selected, the LxT checks the file system in the LxT, similar to Check Disk on a

PC. If a problem is detected, an attempt is made to repair the problem.

Format

Selecting this function formats the internal data storage area in the memory of the LxT. This operates similar to the Format function on a PC. System and measurement settings are preserved.

Format & Restore Defaults

User calibrations and calibration history data are erased when the Format & Restore Defaults function is implemented.

Selecting this function formats the internal data storage area in the memory of the LxT. The LxT is then restored to factory settings.

The Format and Format & Restore Defaults function erases all internal data files, but does not affect data stored in USB memory.

Check/Repair USB

Always shut down the LxT completely before unplugging USB power connections. Otherwise, memory faults and memory wear may occur more quickly over time.

If you believe that the USB mass storage is corrupt, this utility can be used to check and repair the corrupted sectors of the USB mass storage device. Set the USB Host Port to ON, insert the USB mass storage device into the USB connector and run this utility. When the action has been completed, the message shown in FIGURE 15-3 is displayed.

To avoid creating Flash Memory corruption errors, do not unplug USB drives from the USB port on the LxT while the drive is being copied, or if the LxT is within Data Explorer mode.



FIGURE 15-3 USB Check/Repair Done Message

If you still believe that the USB mass storage device is corrupt, a Format USB operation should be performed.

Format USB

CAUTION: When the mass storage device is formatted, all data stored on it will be lost.

If you believe that the Check/Repair USB operation described in "Check/Repair USB" on page 15-3 was not successful, try formatting the USB mass storage device. Set the USB Host Port to ON, insert the USB mass storage device into the USB connector and run this utility. When the action has been completed, the message shown in FIGURE 15-4 is displayed.

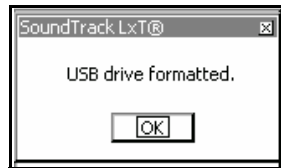

FIGURE 15-4 USB Drive Formatted Message

The USB mass storage device is now formatted using FAT16 file system.

If for some reason the USB mass storage device is not detected, the message shown in FIGURE 15-5 is displayed.

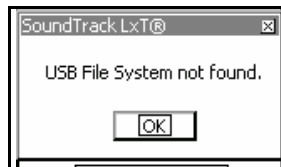
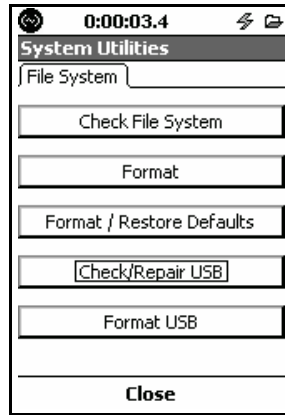

FIGURE 15-5 USB File System Not Found Message

If any of the above operations are initiated while the USB mass storage device is mounted or a "move/copy to USB" operation is in progress, there is a possibility that the file system can become corrupted.

As a result, the operation is denied and the message shown in FIGURE 15-6 is displayed.



*The **Copy to USB** icon appears on the upper left corner of this display.*

FIGURE 15-6 Cannot Check/Repair/Format Message

Parameters Measured

This chapter describes the different acoustic parameters that can be measured, displayed, and stored using the LxT.

Basic Sound Level Measurements

Frequency Weighting

Each of the sound level parameters measured at one time is frequency weighted as set by the user from the Measurement Settings tabs. The frequency weighting for RMS and Impulse averaged sound levels are the same, selected independent from the frequency weighting for peak detection.

RMS and Impulse Weighting

The LxT measures RMS and Impulse averaged sound level values using one of the following user-selected frequency weightings:

- A-Weighting
- C-Weighting
- Z-Weighting

Peak Weighting

The LxT measures peak sound level values using one of the following user-selected frequency weightings:

- A-Weighting
- C-Weighting
- Z-Weighting

RMS Averaging

The exponential averaging time for RMS sound levels is set to one of the following:

- Slow
- Fast

An impulse detector is also available.

Sound Level Metrics Measured

In Table 16-1 "Sound Level Metrics Measured" the symbol X is used to represent the user-selected RMS and Impulse frequency weighting (A, C or Z) and the symbol Y is used to represent the user-selected peak frequency weighting (A, C or Z). The symbol V represents the time weighting Fast, Slow or Impulse.

Metric	Selected RMS Averaging			Peak	Integrated
	Fast	Slow	Impulse		
Instantaneous Sound Level	L_{XF}	L_{XS}	L_{XI}	L_{Ypeak}	
Maximum Sound Level	L_{XFmax}	L_{XSmax}	L_{XImax}	$L_{Ypeak(max)}$	
Minimum Sound Level	L_{XFmin}	L_{XSmin}	L_{XImin}		
Equivalent Level			L_{XIeq}		L_{XVeq}

Table 16-1 Sound Level Metrics Measured

1/1 and/or 1/3 Octave Frequency Spectra

The LxT can perform just 1/1 or 1/3 octave real-time frequency spectra measurements or they can both be measured simultaneously. These spectra are made using a user-selected frequency weighting (A, C or Z). The averaging time is the same as that selected for the sound level measurements (Fast, Slow or Impulse).

Spectral data is displayed on both the **Live** and **Overall** tabs, but only the Overall Data can be stored.

Live Tab

From the **Live** tab, the graphic shows the instantaneous SPL value for all frequencies and the bar to the far right shows the summation value for the entire frequency band. The value corresponding to the cursor position is displayed numerically beneath the graph.

Overall Tab

From the **Overall** tab, the graphic shows the energy equivalent level calculated over the measurement time period at each frequency band and, at the far right, for the summation of all frequency bands. The values displayed digitally beneath the graph represent the following data for the frequency band at the cursor position.

- Leq
- Lmax
- Lmin

Sound Exposure Metrics Measured

The LxT measures two separate and independent sets of sound exposure metrics.

The following parameters are user-selectable:

- Exchange Rate: 3, 4, 5 or 6 dB
- Threshold Enable: Yes or No
- Threshold Level: Numeric entry
- Criterion, Level and Hours: Numeric entries

In Table 16-2: "Sound Exposure Metrics Measured" the symbol X is used to represent the user-selected RMS and Impulse frequency weighting (A, C or Z) and the symbol Y is used to represent the user-selected peak frequency weighting (A, C or Z).

The symbol V is used to represent the user selected time weighting (F, S or I).

Metric	Symbol
Sound Exposure Level, SEL	L_{XVE}
Average Sound Level, Lavg	L_{Xavg}
Time Weighted Average Level, TWA(x)	$TWA_{(8)}$
Noise Dose	DOSE
Projected Noise Dose	ProjDose
Daily Personal Noise Exposure, Lep,d	$LX_{ep,8}$
Sound Exposure, E	E_{XV}
Projected 8 Hour Sound Exposure	E_{XV8}
Projected 40 Hour Sound Exposure	E_{XV40}
SEA	SEA

Table 16-2: Sound Exposure Metrics Measured

Statistical Metrics Measured

Six Ln statistical parameters are measured using the frequency weighting (A, C or Z) and exponential averaging (Slow or Fast) selected when setting up the LxT for a sound level measurement. These six values are user-selected over the range $L_{0,01}$ to $L_{99,99}$.

Community Noise Parameters

When the optional firmware LXT-ENV is enabled, the community noise parameters L_{DN} and L_{DEN} are measured and displayed.

Exceedance Counters

The LxT has three exceedance event counters: two RMS event counters and three peak event counters. For each exceedance there is a threshold level, event counter, and duration.

The thresholds L_{XV} or L_{Ypeak} are the levels that the parameter must exceed to increment the counter and duration. X is RMS frequency weighting, Y is peak frequency weighting and V is time weighting.

The Count is the number of times each parameter has exceeded the preset level.

The duration is the total accumulated duration of all exceedances for a specific parameter.

Miscellaneous Parameters

S.E.A.

SEA is a time integration of peak levels that exceed 120 dB.

C minus A

This measurement represents the difference between the C-weighted and the A-weighted measurements taken simultaneously.

Impulsivity

The values L_{A1eq} , L_{Aeq} and $L_{A1eq} - L_{Aeq}$ are measured and displayed.

Memory Utilization

This chapter presents formulas to calculate the amount of memory used by the parameters that can be stored to internal memory.

Out Of Memory Stop

In order to ensure that all measured data can be stored, the LxT is stopped automatically when the amount of available memory drops to 100 KB.

Overall Data

Each overall data block stored when performing a “Save File” operation utilizes 27 kilobytes of memory.

Session Log

The amount of memory utilized, in bytes, when storing session logs is calculated as follows:

$$52 + 12 * (\text{Number of records})$$

where Number of records includes all Run, Pause, Stop, Voice Message and Marker events.

Measurement History

The amount of memory utilized, in bytes, when storing measurement histories is calculated as follows:

$$52 + \text{Number of Measurement Histories} * (\text{Base Measurement History Size} + \text{Optional Metrics})$$

Base Measurement History Size

$$\text{Base Measurement History Size} = 752 \text{ Bytes}$$

Optional Metrics

$$1/1 \text{ Octave} = 192 \text{ Bytes}$$

$$1/3 \text{ Octave} = 576 \text{ Bytes}$$

$$\text{Dose} = 68 \text{ Bytes}$$

Takt = 4 Bytes

Time History

The amount of memory utilized, in bytes, when storing time history blocks is calculated as follows:

$52 + [16+4*(\text{Number of parameters enabled})]*(\text{Number of records})$

where Number of Records = Number of Samples + Number of Run, Pause and Stop events

Voice Messages

The amount of memory utilized, in bytes, when storing voice messages is calculated as follows:

$24+16000*\text{Record Length}$

where Record Length is in seconds.

Upgrading Firmware and Options

This chapter describes the procedure for upgrading the LxT firmware and/or options.

SLM Utility-G3

In addition to SLM Utility-G3, you can use G4 software to install firmware and option upgrades. Refer to the G4 Software Manual for more information.

SLM Utility-G3 software is used to upgrade firmware and options, download data files, and remotely control the LxT.

Refer to the Larson Davis website (www.LarsonDavis.com) to determine if you are using the most recent version of this software. If not, SLM Utility-G3 is available for download as a zip file from the website.

To install the software, extract the contents of the zip file, run setup.exe, and follow the on-screen prompts. During installation, the following shortcut is placed on the desktop.



Upgrading LxT Firmware

Connect the LxT to the host computer using a CBL138 USB cable, and launch SLM Utility-G3 software.

Initiate communication with the LxT by clicking on the **Connect** icon or selecting **Direct > USB** from the **Connection** menu in SLM Utility-G3. Once a connection has been established, the instrument manager dialog box appears.

Firmware upgrade is performed from the **Manual Control** tab as shown in FIGURE 18-1.

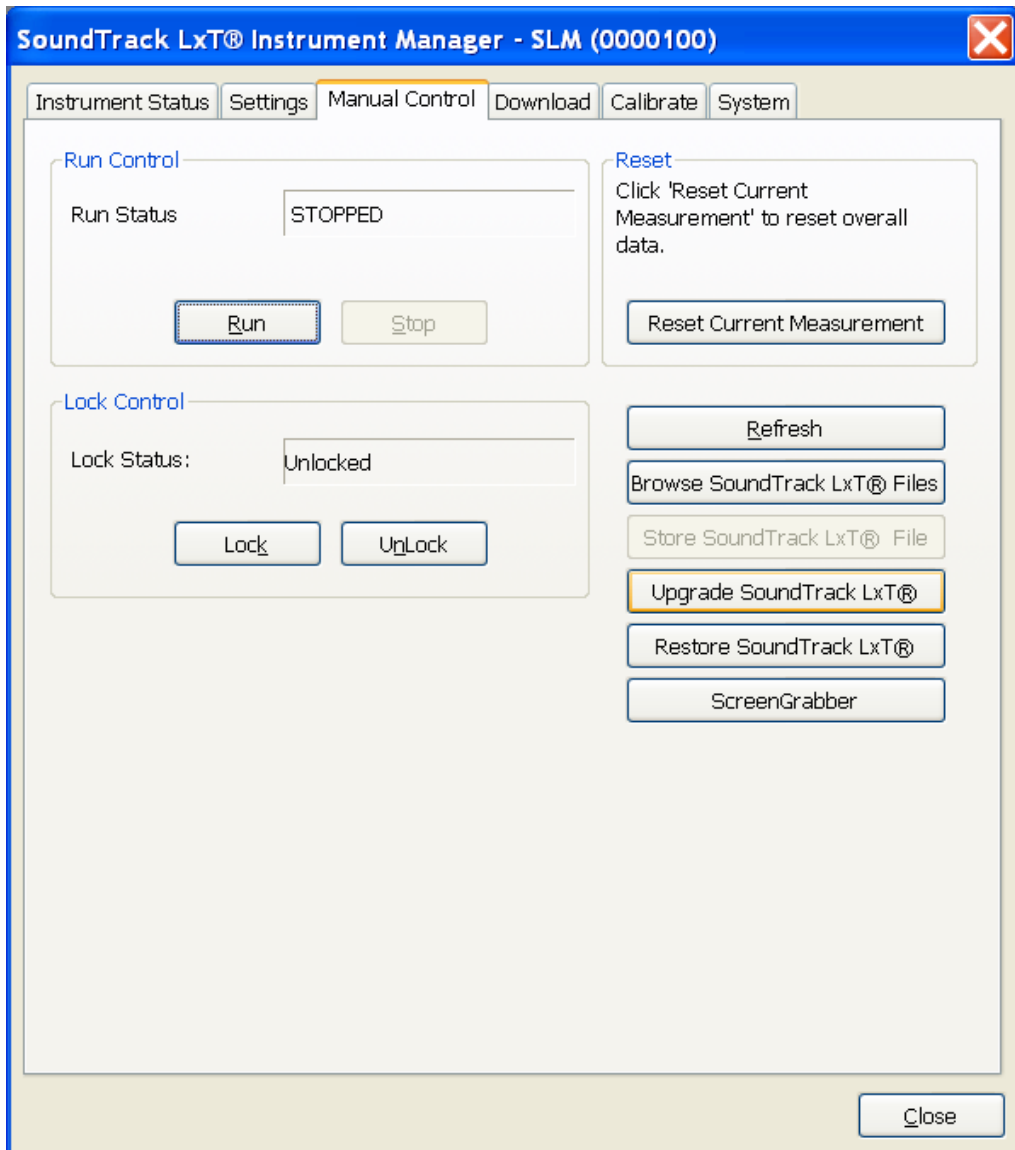

FIGURE 18-1 Manual Control Page

Click the **UpgradeSoundTrack LxT[®]** button and follow the on screen prompts until the **Select File** dialog box shown in FIGURE 18-2 appears.

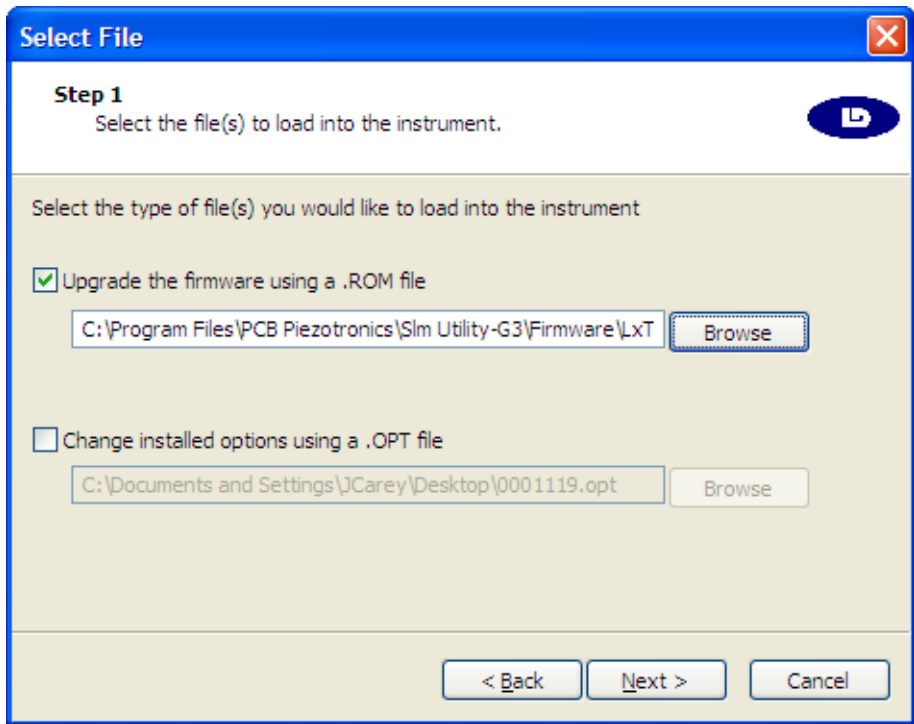

FIGURE 18-2 Select File Menu

Firmware and options can be upgraded at the same time by enabling both check boxes.

Click **Browse** to select the firmware file you wish to send to the LxT. Once you have selected the file, continue to follow the on-screen prompts.

While the firmware upgrade is in progress, The status is indicated on the dialog box shown in FIGURE 18-3.

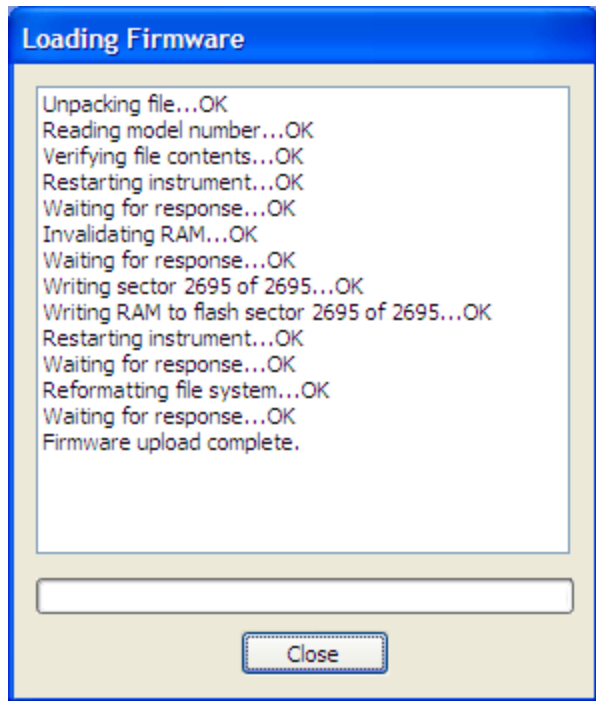

FIGURE 18-3 Firmware Upgrade Progress

Upgrading LxT Options

To enable additional options on the LxT, a new options file is required. To purchase additional options, contact your local representative, found at <http://www.larsondavis.com/sales>.

The procedure for upgrading the options installed on the LxT is the same as for upgrading firmware, except that you select “Changing installed options using a .OPT file” on the dialog box shown in FIGURE 18-2, instead of, or in addition to the option for upgrading the firmware.

A

Technical Specifications

The specifications contained in this chapter are subject to change without notice. Please refer to calibration and measurement results for data on a specific unit.

Standards Met by LxT

The SoundExpert LxT[®] meets the same standards as the LxT1.

The LxT meets the specifications of the following standards:

Instrument	LxT1	LxT2
Sound Level Meter Standards	IEC61672-1 (2013-09) Class 1, Group X IEC60651 (2001) plus Amendment 1 (1993-02) and Amendment 2 (2000-10) Type 1, Group X IEC60804 (2000-10) Type 1, Group X ANSI S1.4-2014 Class 1 ANSI S1.4-1983 (R 2006) plus Amendment S1.4A-1985 (R 2006), Type 1 ANSI S1.43-1997(R2007), Type 1 DIN 45657	IEC61672-1 (2013-09) Class 2, Group X IEC60651 (2001) plus Amendment 1 (1993-02) and Amendment 2 (2000-10) Type 2, Group X IEC60804 (2000-10) Type 2, Group X ANSI S1.4-2014 Class 1 ANSI S1.4-1983 (R 2006) plus Amendment S1.4A-1985 (R 2006), Type 2 ANSI S1.43-1997(R2007), Type 2 DIN 45657
Octave Filter Standards (Options OB1 or OB3 only)	IEC61260 Ed. 1.0 (1995-08) plus Amendment 1 (2001-09), 1/1 and 1/3-octave Bands: Class 0, Group X, all filters using a 377B02 or 377C20 microphone. Otherwise, Class 1 ANSI S1.11-2004 (R2009) Class 1	IEC61260 Ed. 1.0 (1995-08) plus Amendment 1 (2001-09), 1/1 and 1/3-octave Bands: Class 0, Group X, all filters using a 377B02 or 377C20 microphone. Otherwise, Class 1 ANSI S1.11-2004 (R2009) Class 1
Personal Noise Dosimeter Standards	IEC61252 Ed. 1.1 (2002) Type 1 ANSI S1.25-1991 (R2007) Class 1	IEC61252 Ed. 1.1 (2002) Type 2 ANSI S1.25-1991 (R2007) Class 2
Safety Requirements for Electrical Equipment for Measurement, Control and Laboratory Use	IEC61010-1 Ed. 2.0 (2001-02)	IEC61010-1 Ed. 2.0 (2001-02)

Table A-1 Standards Met by LxT

LxT Specifications

Features

Class 1 Precision Integrating Sound Level Meter with real-time 1/3 Octave Filters.
High contrast 1/8th VGA LCD display with white LED backlight; sunlight readable
Icon-driven graphic user interface
Soft rubber keys
Large dynamic range
Time weightings: Slow, Fast, Impulse, Integration and Peak
Frequency weightings: A, C, Z
1/1 and 1/3 octave frequency analysis available
Voice message annotation available, which includes headset
L _n statistics (L0.01 through L99.9 available)
Blaze software available for setup, control, high speed data download, analysis and reporting
Multi-tasking processor allows measuring while viewing data or transferring data
Data Secure Feature saves data to permanent memory every minute
AC/DC outputs to recorder
Long battery life; 16 hours continuous measurement
Field-upgradeable firmware: keeps instrument current with the latest measurement features
Two-year limited warranty
Class 1 Precision Integrating Sound Level Meter with real-time 1/3 Octave Filters, classified as group X for the emission of, and susceptibility to, radio frequency fields.

Table A-2 LxT Features

Sound Level Meter Specifications

RMS Time weighting	Slow, Fast or Impulse
Frequency Weightings	A, C or Z See Frequency Weightings on page A-7.
Peak detector Frequency weighting	A, C or Z
Reference range:	Normal range
Exchange rate	3, 4, 5, or 6 dB
Sample rate	51,200 Hz
Peak rise time	30 μ S
Integration method	Linear or Exponential

Table A-3 Sound Level Meter Specifications

Performance Specifications

		LxT1	LxT1L	LxT2	LxT2L	Direct In
Measurement Range¹	A	39 to 140 dB	27 to 118 dB	37 to 139 dB	31 to 125 dB	13 to 117 dB μ V
	C	39 to 140 dB	29 to 118 dB	37 to 139 dB	35 to 125 dB	10 to 117 dB μ V
	Z	44 to 140 dB	34 to 118 dB	42 to 139 dB	42 to 125 dB	16 to 117 dB μ V
Noise Floor¹	A	29 dB	17 dB	27 dB	21dB	2.8 dB μ V
	C	29 dB	19 dB	27 dB	25dB	1.3 dB μ V
	Z	34 dB	24 dB	32 dB	32dB	5.6 dB μ V
Linearity Range²	A	≥ 104 dB 36 to 140 dB	≥ 102 dB 16 to 118 dB	≥ 103 dB 36 to 139 dB	≥ 102 dB 24 to 125 dB	≥ 106 dB μ V 11 to 117 dB μ V
	C	≥ 105 dB 35 to 140 dB	≥ 100 dB 18 to 118 dB	≥ 104 dB 35 to 139 dB	≥ 100 dB 26 to 125 dB	≥ 107 dB μ V 10 to 117 dB μ V
	Z	≥ 103 dB 37 to 140 dB	≥ 93 dB 25 to 118 dB	≥ 100 dB 39 to 139 dB	≥ 93 dB 33 to 125 dB	≥ 103 dB μ V 14 to 117 dB μ V
Peak Range²	A	99- 143 dB	77 - 121 dB	98 - 142 dB	84 - 128 dB	76 - 120 dB μ V
	C	96 - 143 dB	74 - 121 dB	95 - 142 dB	81 - 128 dB	73 - 120 dB μ V
	Z	101 - 143 dB	79 - 121 dB	100 - 142 dB	86 - 128 dB	78 - 120 dB μ V
SPL Max Level¹		140 dB	118 dB	139 dB	125 dB	117 dB μ V
Peak Max Level		143 dB	121 dB	142 dB	128 dB	120 dB μ V
¹ Microphone and electrical self-noise included						
² Electrical Measurements						

Table A-4 LxT Performance Specifications

Physical Characteristics

Length with microphone and preamplifier	11.35 inches	29 cm
Length, instrument body only	8.80 inches	22.4 cm
Width	2.80 inches	7.10 cm
Depth	1.60 inches	4.10 cm
Weight with batteries; no preamplifier or microphone	1.0 lb	471 g

Table A-5 Physical Characteristics

Weight with batteries, preamplifier and microphone	1.1 lb	513 g
--	--------	-------

Table A-5 Physical Characteristics

General Specifications

Reference level	114.0 dB re 20 μ Pa
Reference level range	Single large Range for SLM Normal for OBA option
Reference frequency	1000 Hz
Reference direction	0°, perpendicular to the microphone diaphragm
Temperature effects	$\leq \pm 0.5$ dB error between -10 °C and 50 °C
Storage temperature	-20 °C to 70 °C
Humidity effects	$\leq \pm 0.5$ dB error from 30% and 90% relative humidity at 40 °C
Equivalent microphone impedance	12 pF for Larson Davis 1/2" microphone
Range level error (OBA option)	$\leq \pm 0.1$ dB relative to the reference range
Digital Display Update Rate	Four times per second (0.25 sec between updates). First display indication is available 0.25 seconds after initiation of a measurement
Effect of an extension cable (EXCXXX) on calibration	None (up to 200 feet)
Electrostatic Discharges	The instrument is not adversely affected by electrostatic discharges

Table A-6 General Specifications

Resolution Specifications

Resolution of data shown on the instrument's display is specified in Table A-7. Higher resolution level, dose and elapsed time data are available via I/O commands and data file downloads.

Levels	0.1dB
Dose	0.01%
Elapsed time	0.1 second
Real time clock	1 second
Calendar	01 Jan 2005 - 31 Dec 2038

Table A-7 Resolution Specifications

Frequency Weightings

Nominal Frequency	Exact Frequency	Z-Weight (Ideal)	A Weight (Ideal)	C Weight (Ideal)	Electrical Limits: Class 1	Microphone Limits: Class 1	Microphone Limits: Class 2
10	10.00	-0.0	-70.4	-14.3	+ 1.4, - 0.7	±1.5	±2.0
12.5	12.59	-0.0	-63.4	-11.2	+ 0.5, - 0.6	±1.3	±1.8
16	15.85	-0.0	-56.7	-8.5	+ 0.4, -0.5	±1.0	±1.7
20	19.95	-0.0	-50.5	-6.2	+ 0.3, -0.4	±0.5	±1.5
25	25.12	-0.0	-44.7	-4.4	±0.2	±0.5	±1.5
31.5	31.62	-0.0	-39.4	-3.0	±0.2	±0.5	±1.5
40	39.81	-0.0	-34.6	-2.0	±0.2	±0.5	±1.0
50	50.12	-0.0	-30.2	-1.3	±0.5	±0.5	±1.0
63	63.10	-0.0	-26.2	-0.8	±0.5	±0.5	±1.0
80	79.43	-0.0	-22.5	-0.5	±0.5	±0.5	±1.0
100	100.00	-0.0	-19.1	-0.3	±0.5	±0.5	±1.0
125	125.00	0.0	-16.1	-0.2	±0.5	±0.5	±1.0
160	158.50	0.0	-13.4	-0.1	±0.2	±0.5	±1.0
200	199.50	0.0	-10.9	0.0	±0.2	±0.5	±1.0
250	251.20	0.0	-8.6	0.0	±0.2	±0.5	±1.0
315	316.20	0.0	-6.6	0.0	±0.2	±0.5	±1.0
400	398.10	0.0	-4.8	0.0	±0.2	±0.5	±1.0
500	501.20	0.0	-3.2	0.0	±0.2	±0.5	±1.0
630	631.00	0.0	-1.9	0.0	±0.2	±0.5	±1.0
800	794.30	0.0	-0.8	0.0	±0.2	±0.5	±1.0

Table A-8 Frequency Weightings

Nominal Frequency	Exact Frequency	Z-Weight (Ideal)	A Weight (Ideal)	C Weight (Ideal)	Electrical Limits: Class 1	Microphone Limits: Class 1	Microphone Limits: Class 2
1000	1000.00	0.0	0.0	0.0	±0.2	±0.5	±1.0
1250	1259.00	0.0	0.6	0.0	±0.2	±0.5	±1.0
1600	1585.00	0.0	1.0	-0.1	±0.2	±0.5	±1.3
2000	1995.00	0.0	1.2	-0.2	±0.2	±0.5	±1.3
2500	2512.00	0.0	1.3	-0.3	±0.2	±0.5	±1.7
3150	3162.00	0.0	1.2	-0.5	±0.2	±0.5	±1.7
4000	3981.00	0.0	1.0	-0.8	±0.2	±0.5	±2.0
5000	5012.00	0.0	0.5	-1.3	±0.2	± 0.75	±2.3
6300	6310.00	0.0	-0.1	-2.0	±0.2	±1.0	±3.0
8000	7943.00	0.0	-1.1	-3.0	±0.2	±1.25	±3.3
10000	10000.00	0.0	-2.5	-4.4	±0.2	±1.50	±3.3
12500	12590.00	0.0	-4.3	-6.2	±0.2	±1.75	±3.3
16000	15850.00	0.0	-6.6	-8.5	±0.3	±2.0	±3.3
20000	19950.00	0.0	-9.3	-11.2	±0.5	±2.0	±3.3

Table A-8 Frequency Weightings

Typical Z-Weight Frequency Response

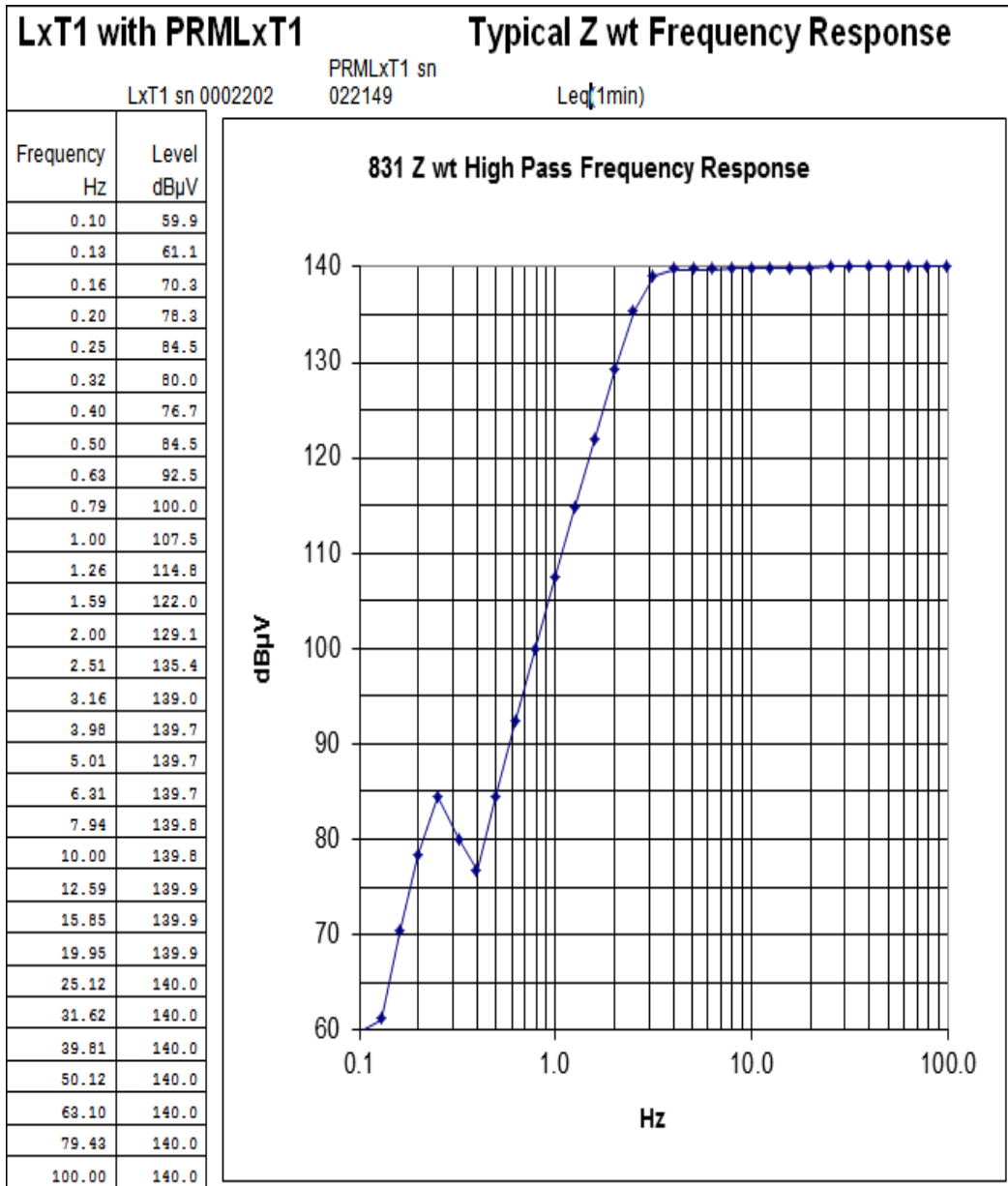

AC/DC Output

The purpose of the AC output is to drive a headset to listen to live and recorded sounds. It may be used for other purposes, but may not function as expected as a source for additional analysis equipment. The output is amplified for listening purposes and therefore is limited in its maximum output to be less than the instrument's maximum input level. For connection to external analysis equipment use the adapter ADP015 and cable EXC006 to extract the signal directly from the preamplifier output. Using the PRMLxT series preamplifiers puts a DC bias on the output of the BNC connector of the ADP015 of approximately + 3.4 Volts.

AC Output Voltage Range	$\pm 2.3 V_{\text{peak}}$ maximum output 0.5 mV to 1.6 V _{rms} sine wave (~70 dB dynamic range)
AC Output Gain (relative to instrument input)	+ 39.2 dB
AC Output Frequency Weighting	Signal is unweighted with frequency limitations imposed by hardware design (see below)
AC Output Frequency Response	20 Hz to 23.6 kHz (-3 dB), $R_L = 10 \text{ k}\Omega$ 21 Hz to 23.6 kHz (-3 dB), $R_L = 600 \Omega$ 95 Hz to 23.6 kHz (-3 dB), $R_L = 16 \Omega$
AC Output Recommended Loads	Headset with 16 Ω or greater speaker impedance Resistive loads greater than 600 Ω for maximum frequency response range.
AC Output Impedance	Low impedance headset speaker driver with 100 μF coupling capacitor. $Z = 1.5 + 1592/f$, where Z is output impedance in Ω (Ohms) and f is frequency in Hz. <i>Instrument readings are not affected by AC output loading, although with a large signal output, a short circuit may draw excessive power and cause the instrument to turn off.</i>
AC Output Phase and Delay	- 180° relative to input, 128 μs digital delay
DC Output Frequency Weighting	Follows the SLM Frequency Weighting: A, C or Z
DC Output Time Weighting	Follows the SLM Detector: F, S or I

Table A-9 AC/DC Output

DC Output Voltage Range	0 to +3 Volt (0 to 300 dB) $V_0 = \text{SPL}/100$ $\text{SPL} = 100 * V_0$ or Sensitivity = 0.01 V/dB with resolution of 0.001 V
DC Output Impedance	3650 Ω
DC Output Recommended Loads	$\geq 1 \text{ M}\Omega$ for less than 0.4% error A 10 $\text{M}\Omega$ DC Voltmeter represents negligible error (-0.036%). The output resistance can be accounted for in the interface design. For example, if a chart recorder has an input load of 10 k Ω , the gain can be set to 1.365 to correct for the loading.

Table A-9 AC/DC Output

Min/Max Integration Time

Minimum and maximum integration time for measurement of time-average levels and sound exposure levels.

	Time Average Levels and Sound Exposure Levels, (s)
Minimum	0.1
Maximum (daily autostore enabled)	Unlimited
Maximum (daily autostore disabled, errors less than 0.5 dB)	> 23 days
	Dosimeter Metrics: TWA, Dose (s)
Minimum	0.1
Maximum	Unlimited

Table A-10 Min/Max Integration Time

Time of Day Drift

The LxT displays the time of day and also time-stamps various single events (i.e. maximum level).

Two different time reference sources are used in the LxT depending on whether the unit power is on or off, as described in Table A-11.

Instrument Power State	Ambient Temperature	Nominal Drift in 24 hours
LxT On	25 °C	± 2.6 s (±30 ppm)
	-10 °C to + 50 °C	± 5 s (±50 ppm)
LxT Off	25 °C	± 2 s (±20 ppm)
	-10 °C to + 50 °C	+0, -5 s (±50 ppm) See FIGURE A-1

Table A-11 Time of Day Drift

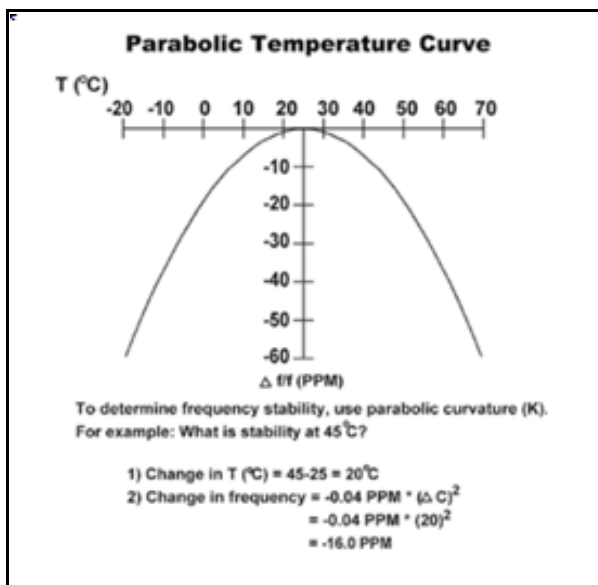

FIGURE A-1 Frequency Stability vs Temperature

Power Supply

Batteries	4-AA (LR6) Alkaline, NiMH or Lithium cells
External Power	Powered through USB interface from computer or from PSA029 AC to DC Power Adapter: 5 Volt \pm 5% required. <i>Applying a voltage greater than specified can damage the instrument and void the warranty.</i>

Table A-12 Power Supply Specifications

Battery Operating Lifetime

Battery	Operating Life, Hours
Alkaline cells	16
NiMH rechargeable cells, 2500 mAH (external charger required)	16
Lithium cells	30

Table A-13 Battery Operating Lifetime

Battery Life Test Conditions

Continuous run until instrument shuts off due to low battery.

Measuring 1/3 octave data

Power Save feature set to "Never"

Memory Retention

Data Memory	Permanently stored in non-volatile flash memory every one minute. If power fails, maximum data loss is less than one minute. Always shut down the LxT completely before unplugging USB power connections. Otherwise, memory faults and memory wear may occur more quickly over time. Also, to avoid creating Flash Memory corruption errors, do not unplug USB drives from the USB port on the LxT while the drive is being copied, or if the LxT is within Data Explorer mode.
Real-time Clock	≥ 10 minutes

Table A-14 Memory Retention Without Batteries or External Power

PSA029 AC to DC USB Power Adapter Specifications

DC Output Voltage	5 Volts
DC Output Regulation	Line: ± 5% Load: ± 5%
DC Output Load	Minimum: 0 A Maximum: 0.5 A
DC Output Connector	USB Type A Jack (USB Cable, type A to mini-B supplied)
AC Input Voltage	90 to 264 Vac
AC Input Frequency	47 to 63 Hz
AC Input Current	0.15 Arms, 120 Vac at maximum load 0.08 Arms, 230 Vac at maximum load
Ac Inrush Current	30 A for 120 Vac at maximum load 60 A for 240 Vac at maximum load
Efficiency	55% typical
Power Saving	0.3 W maximum, no load, 230 Vac, 50 Hz
Temperature	Operation: 0 to 45 °C Storage: - 40 °C to + 85 °C

Table A-15 PSA029 AC to DC USB Power Adapter Specifications

Humidity	Operation: 10% to 90% Storage: 5% to 85%
Emissions	FCC Part 15 Class B EN55022 Class B
Immunity	EN61000-4-2, Level 4 EN61000-4-3, Level 2 EN61000-4-4, Level 2 EN61000-4-5, Level 3 EN61000-4-6, Level 3 EN61000-4-11
Harmonic	EN6100-3-2 (A1 +A2 + A14)
Flicker	EN6100-3-3
Leakage Current	0.20 μ A maximum 254 Vac, 54 Hz
Dielectric Withstand (Hipot)	3,000 Vac, 1 minute, 10 mA
MTBF (Full Load, 25° C)	> 150 kHrs.
AC Input Plugs (supplied)	USA: RPA Europe: RPE UK: RPK Australia: RPS
Dimensions/Weight	Length: 75.32 mm (2.97 in) Height: 31.67 mm (1.25 in) Width: 45.96 mm (1.81 in) Weight: 61.1 g (2.16 oz)

Table A-15 PSA029 AC to DC USB Power Adapter Specifications

Electromagnetic Emission

Declaration of Conformity

PCB® Piezotronics, Inc. declares that:

LxT Sound Level Meter

has been measured in representative configuration with: PRMLxT1 preamplifier, 377B02 microphone and the following cables: EXC010 microphone extension cable, CBL138 USB interface cable and

CBL139 AC/DC output cable with an applied acoustic field of 74 dB at 1 kHz in accordance with the following directives:

- 89/336/EEC The Electromagnetic Compatibility Directive and its amending directives has been designed and manufactured to the following specifications:
- EN 50081-1 (1992) - Electromagnetic compatibility - Generic emission standard Part 1. Residential, commercial, and light industry.
- EN 50082-2 (1995) - Electromagnetic compatibility - Generic immunity standard Part 2. Industrial environment.



EU Declaration of Conformity PS086
In Accordance with ISO/IEC 17050

Manufacturer: Larson Davis, a Division of PCB Piezotronics 1681 West 820 North Provo, Utah, USA 84601	Authorized European Representative: PCB Piezotronics Europe GmbH Porschesstrasse 20-30 41836 Hückelhoven, Germany
--	--

Certifies that type of equipment: Model LxT – Sound Meter

Whose Product Models include: LxT1

This declaration is applicable to all LxT Sound Meters of the above series which have the CE mark on their data sheets and where those data sheets refer to this Declaration of Conformity. The data sheets for all model numbers referenced above which include the CE mark on such data sheets and refer to this Declaration of Conformity are hereby incorporated by reference into this Declaration.

Conform to the following EU Directive(s) when installed per product documentation:	2014/30/EU 2014/35/EU 2011/65/EU	EMC Directive Low Voltage Directive RoHS Directive
--	--	--

Standards to which Conformity is Declared:

Harmonized Standards	EN 61326-1:2013 EN 61010-1:2010 EN50581:2012	Electrical Equipment for Measurement, Control and Laboratory Use- EMC Safety requirements for electrical equipment for measurement, control, and laboratory use - Part 1: General requirements Technical documentation for the assessment of electrical and electronic products with respect to the restriction of hazardous substances
Emissions Test Standards	EN 55011 (2009)	Industrial, scientific and medical(ISM) radio frequency equipment Electromagnetic disturbance characteristics- Limits and methods of Measurement Class B
Immunity Test Standards (Non-OJEU)	EN 61000-4-2:2008 EN 61000-4-3:2008 EN 61000-4-4:2012 EN 61000-4-5:2014 EN 61000-4-6:2014 EN 61000-4-8:2001	Electrostatic Discharge (ESD) immunity Radiated, radio-frequency, electromagnetic field immunity Electrical fast transient (EFT)/burst immunity, ±2 kV (5/50 ns, 5 kHz), Surge immunity, ±1 kV Immunity to RF conducted line disturbances, Power frequency magnetic field immunity, 80 A/m, 50/60 Hz
Test Reports	EMC and Safety Report	D1247.0015(A)

I, the undersigned, hereby declare that the equipment specified above conforms to the above Directive(s) Standard(s)

Place: Provo, UT Date: 08/02/2017

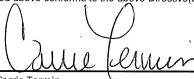
Signature: 

Name: Carrie Termin

Title: Regulatory Affairs and Product Certification Specialist

- ISO 9001 Certified PCB Piezotronics, Inc. Phone: 716-684-0001 FAX: 716-684-0987

PSPS086 Rev. C 08/02/2017

1/1 and 1/3 Octave Filters

The 1/1 and 1/3 octave filters (LXT-OB1 and LXT-OB3 Options) comply with all requirements of IEC 61260:1995 including amendment 1 (2001) for Class 1. These digital filters are sampled at a rate of 51,200 samples per second, with base X10 center frequencies and having real-time performance for all filters. The 0 dB gain setting is the reference range and the reference input signal is 1 Volt rms at 1 kHz.

Frequency Range

1/1 Octave Filters: 8 Hz to 16 kHz

1/3 Octave Filters: 6.3 Hz to 20 kHz

Filter Shapes

The following figures present the filter shapes for the 1/1 and 1/3 octave bands centered at 1 kHz. Overlaid with these curves are the limit curves associated with IEC 61260:1995 Class 1.



Sound Level Meter Model: LxT1 Serial Number: 0000033 Firmware:
Certificate of 1000.0 Hz Full Octave Filter Shape

This Sound Level Meter (including attached PRMLXT1 preamplifier and ADP005 18pF input adapter) was calibrated with a reference 1kHz sine wave. The instrument's 1000.0 Hz filter response was then electrically tested using a 137.00 dB SPL sinewave at selected frequencies as specified in IEC 61260-am1 (2001-09). Instrument is in normal OBA range. Instrument has +20dB gain.

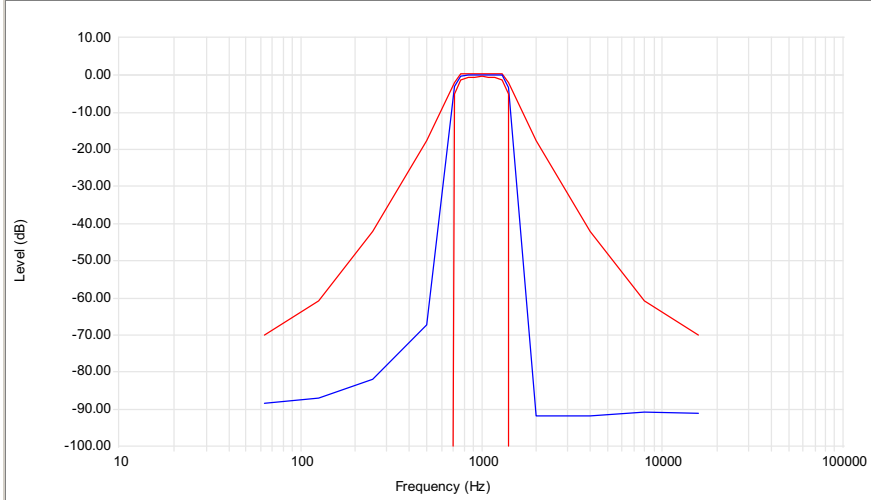

Freq (Hz)	Measured (dB)	Uncert (dB)	Limits (dB)	Freq (Hz)	Measured (dB)	Uncert (dB)	Limits (dB)
63.10	-88.46	0.10	-70.00, -inf	1090.18	0.00	0.10	+0.30, -0.40
125.89	-87.18	0.10	-61.00, -inf	1188.50	0.00	0.10	+0.30, -0.60
251.19	-81.81	0.10	-42.00, -inf	1295.69	0.01	0.10	+0.30, -1.30
501.19	-67.18	0.10	-17.50, -inf	1412.54	-3.15	0.10	-2.00, -5.00
707.95	-3.11	0.10	-2.00, -5.00	1995.26	-91.94	0.10	-17.50, -inf
771.79	-0.21	0.10	+0.30, -1.30	3981.07	-91.92	0.10	-42.00, -inf
841.40	-0.00	0.10	+0.30, -0.60	7943.28	-90.84	0.10	-61.00, -inf
917.28	-0.00	0.10	+0.30, -0.40	15848.93	-91.27	0.12	-70.00, -inf
1000.00	-0.00	0.10	+0.30, -0.30				

Uncertainties are given as expanded uncertainty at ~95% confidence level (k=2).

This instrument is in compliance with IEC 61260-am1 (2001-09) (Class 0) and ANSI S1.11-2004 (Class 0).

Technician: Leroy H

Test Date: 05 Apr 2005 17:38:11

Table A-16 Passband of 1kHz 1/1 Octave Filter



Sound Level Meter Model: LxT1 Serial Number: 0000033 Firmware:
Certificate of 1000.0 Hz Third Octave Filter Shape

This Sound Level Meter (including attached PRMLXT1 preamplifier and ADP005 18pF input adapter) was calibrated with a reference 1kHz sine wave. The instrument's 1000.0 Hz filter response was then electrically tested using a 137.00 dB SPL sine wave at selected frequencies as specified in IEC 61260-am1 (2001-09). Instrument is in normal OBA range. Instrument has +20dB gain.



Freq (Hz)	Measured (dB)	Uncert (dB)	Limits (dB)	Freq (Hz)	Measured (dB)	Uncert (dB)	Limits (dB)
185.46	-90.61	0.10	-70.00, -inf	1026.67	-0.00	0.10	+0.30, -0.40
327.48	-82.27	0.10	-61.00, -inf	1055.75	0.00	0.10	+0.30, -0.60
531.43	-68.01	0.10	-42.00, -inf	1087.46	-0.14	0.10	+0.30, -1.30
772.57	-75.25	0.10	-17.50, -inf	1122.02	-2.56	0.10	-2.00, -5.00
891.25	-2.50	0.10	-2.00, -5.00	1294.37	-93.15	0.10	-17.50, -inf
919.58	-0.29	0.10	+0.30, -1.30	1881.73	-97.63	0.10	-42.00, -inf
947.19	0.01	0.10	+0.30, -0.60	3053.65	-96.71	0.10	-61.00, -inf
974.02	-0.00	0.10	+0.30, -0.40	5391.95	-97.53	0.10	-70.00, -inf
1000.00	-0.00	0.10	+0.30, -0.30				

Uncertainties are given as expanded uncertainty at ~95% confidence level (k=2).

This instrument is in compliance with IEC 61260-am1 (2001-09) (Class 0) and ANSI S1.11-2004 (Class 0).

Technician: Leroy H

Test Date: 05 Apr 2005 17:38:11

Table A-17 Filter Skirts of 1kHz 1/3 Octave Filter

Position of Instrument and Operator

When making a measurement, it is recommended that the observer be positioned as far behind and to the right of the instrument as possible to minimize interference of the sound field at the microphone resulting from body reflections. When using the LxT, the meter is held in one hand with the arm extended away from the body. Better results can be obtained by using a tripod.

Effect of Windscreen

The corrections which should be subtracted from the measured data when using the Larson-Davis Model WS001 3 1/2 inch diameter windscreen with a 1/2 inch Larson-Davis microphone are as indicated in the following table.

Directional Response Effect of 3 1/2 Inch Wind Screen on 377B02 Microphone Attached to LxT1													
Frequency (Hz)	Angle from Reference direction (degrees)												
	0	15	30	45	60	75	90	105	120	135	150	165	180
251.19	0.00	0.00	0.00	0.00	0.00	0.00	0.00	0.00	0.00	0.00	0.00	0.00	0.00
266.07	0.00	0.00	0.03	-0.03	0.00	0.00	0.00	-0.03	0.03	0.00	-0.03	-0.03	0.00
281.84	0.00	0.10	0.07	-0.03	-0.07	0.00	0.03	0.00	0.07	0.00	-0.03	0.03	0.00
298.54	0.07	0.07	0.00	0.00	-0.03	0.00	0.03	-0.03	-0.03	0.03	-0.10	0.03	0.00
316.23	0.00	0.03	0.07	0.00	-0.07	-0.03	0.00	-0.03	0.03	-0.03	-0.10	0.07	0.00
334.97	0.00	0.00	0.03	0.00	-0.07	-0.03	0.07	-0.13	0.00	0.00	-0.07	0.07	0.00
354.81	0.03	0.07	0.10	-0.03	-0.07	0.00	0.00	-0.03	0.03	0.03	-0.03	0.03	0.00
375.84	0.03	0.07	0.03	0.00	-0.03	-0.03	0.00	-0.03	0.03	0.00	-0.10	0.00	0.00
398.11	0.00	0.00	0.10	-0.03	-0.03	0.00	0.00	-0.03	0.07	-0.03	-0.07	0.07	0.07
421.70	0.00	0.00	0.07	0.03	-0.07	-0.03	0.00	-0.03	0.03	0.00	-0.07	0.00	0.00
446.68	0.00	0.03	0.03	-0.03	0.00	-0.03	0.10	0.03	0.03	0.00	0.00	0.00	0.00
473.15	0.03	0.03	0.03	0.00	0.03	-0.03	0.07	0.00	0.03	0.00	-0.07	0.03	0.00
501.19	0.10	0.10	0.13	0.07	-0.03	0.07	0.00	0.00	0.13	0.10	-0.07	0.03	0.00
530.88	0.03	0.10	0.13	0.07	-0.07	0.07	0.03	0.03	0.07	0.00	-0.03	0.03	0.00
562.34	0.10	0.10	0.13	0.07	0.03	0.07	0.00	-0.03	0.13	0.10	-0.03	0.00	0.07
595.66	0.07	0.10	0.13	0.07	-0.03	0.03	0.00	0.00	0.10	0.07	-0.03	0.07	0.00
630.96	0.03	0.00	0.07	-0.03	0.00	0.07	0.10	0.07	0.13	0.10	0.03	0.10	0.10
668.34	0.10	0.10	0.13	0.07	0.03	0.00	0.03	0.03	0.07	0.00	0.03	0.10	0.00
707.95	0.10	0.10	0.13	0.07	0.03	0.07	0.10	0.07	0.03	0.10	0.03	0.10	0.00
749.89	0.10	0.10	0.13	0.07	0.00	-0.03	0.10	0.07	0.13	0.10	0.03	0.10	0.10
794.33	0.10	0.10	0.13	0.07	0.03	0.13	0.10	0.07	0.13	0.10	0.03	0.10	0.10
841.40	0.03	0.07	0.10	0.07	0.03	0.07	0.10	0.10	0.03	0.10	0.03	0.10	0.10
891.25	0.10	0.07	0.10	0.00	0.03	0.07	0.03	0.07	0.13	0.07	0.03	0.10	0.10
944.06	0.13	0.17	0.20	0.07	0.07	0.07	0.13	0.17	0.20	0.17	0.03	0.17	0.13
1000.00	0.20	0.10	0.13	0.07	0.03	0.17	0.10	0.17	0.23	0.10	0.03	0.10	0.10
1059.25	0.10	0.10	0.23	0.17	0.13	0.07	0.10	0.07	0.13	0.10	0.03	0.10	0.10
1122.02	0.20	0.23	0.23	0.13	0.13	0.17	0.10	0.17	0.23	0.20	0.13	0.13	0.10
1188.50	0.20	0.10	0.23	0.07	0.13	0.17	0.10	0.17	0.13	0.20	0.13	0.17	0.10
1258.93	0.13	0.17	0.23	0.17	0.13	0.17	0.23	0.13	0.23	0.17	0.13	0.10	0.20
1333.52	0.20	0.20	0.33	0.27	0.13	0.17	0.20	0.23	0.23	0.20	0.13	0.20	0.10
1412.54	0.20	0.20	0.23	0.17	0.23	0.17	0.20	0.27	0.23	0.20	0.13	0.17	0.20
1496.24	0.23	0.20	0.23	0.17	0.23	0.17	0.20	0.27	0.23	0.27	0.13	0.10	0.20
1584.89	0.33	0.30	0.37	0.30	0.27	0.27	0.33	0.27	0.30	0.27	0.20	0.27	0.30
1678.80	0.30	0.30	0.40	0.37	0.33	0.27	0.30	0.27	0.33	0.20	0.17	0.20	0.27
1778.28	0.40	0.40	0.43	0.37	0.33	0.33	0.40	0.37	0.33	0.40	0.13	0.30	0.30
1883.65	0.40	0.40	0.43	0.37	0.33	0.37	0.40	0.37	0.33	0.30	0.23	0.30	0.30
1995.26	0.40	0.50	0.43	0.47	0.43	0.47	0.40	0.37	0.37	0.40	0.23	0.33	0.30
2113.49	0.50	0.50	0.53	0.47	0.43	0.47	0.40	0.47	0.43	0.37	0.33	0.33	0.40
2238.72	0.50	0.50	0.53	0.47	0.43	0.47	0.50	0.47	0.47	0.40	0.30	0.40	0.40
2371.37	0.50	0.50	0.53	0.47	0.43	0.47	0.50	0.47	0.53	0.50	0.33	0.50	0.40
2511.89	0.50	0.57	0.53	0.57	0.50	0.57	0.53	0.53	0.53	0.50	0.37	0.47	0.47
2660.73	0.53	0.53	0.57	0.57	0.50	0.50	0.60	0.50	0.53	0.50	0.43	0.50	0.43
2818.38	0.57	0.53	0.57	0.60	0.50	0.50	0.53	0.53	0.57	0.57	0.43	0.57	0.50
2985.38	0.40	0.50	0.43	0.57	0.43	0.50	0.57	0.53	0.57	0.57	0.37	0.50	0.50
3162.28	0.40	0.40	0.53	0.50	0.33	0.57	0.50	0.47	0.53	0.50	0.43	0.50	0.50
3349.65	0.30	0.40	0.37	0.37	0.37	0.43	0.40	0.40	0.43	0.43	0.40	0.50	0.50
3548.13	0.23	0.27	0.33	0.30	0.23	0.37	0.33	0.33	0.37	0.40	0.33	0.40	0.40

Continued on next page

Frequency (Hz)	Angle from Reference direction (degrees)													
	0	15	30	45	60	75	90	105	120	135	150	165	180	
3758.37	0.20	0.23	0.13	0.17	0.23	0.27	0.20	0.23	0.33	0.37	0.27	0.40	0.30	
3981.07	0.10	0.10	0.13	0.13	0.00	0.13	0.10	0.10	0.23	0.20	0.13	0.27	0.23	
4216.97	0.03	0.00	0.10	0.03	-0.10	0.07	0.00	-0.03	0.07	0.03	0.03	0.10	0.13	
4466.84	0.00	-0.07	-0.07	-0.07	-0.17	-0.07	-0.10	-0.10	-0.07	0.00	-0.07	0.00	0.00	
4731.51	-0.30	-0.20	-0.17	-0.23	-0.27	-0.30	-0.30	-0.43	-0.27	-0.20	-0.37	-0.20	-0.20	
5011.87	-0.17	-0.20	-0.17	-0.30	-0.27	-0.23	-0.40	-0.33	-0.37	-0.40	-0.37	-0.30	-0.30	
5308.84	0.00	-0.10	-0.07	-0.23	-0.30	-0.33	-0.40	-0.43	-0.47	-0.50	-0.60	-0.43	-0.43	
5623.41	0.00	-0.07	-0.03	-0.17	-0.20	-0.33	-0.37	-0.43	-0.47	-0.50	-0.53	-0.43	-0.43	
5956.62	0.17	0.07	0.10	-0.13	-0.17	-0.23	-0.33	-0.37	-0.43	-0.50	-0.57	-0.50	-0.40	
6309.57	0.10	0.20	0.23	-0.03	-0.07	-0.03	-0.10	-0.33	-0.37	-0.40	-0.47	-0.40	-0.30	
6683.44	0.13	0.10	0.20	0.07	-0.03	-0.03	-0.13	-0.17	-0.27	-0.33	-0.40	-0.40	-0.20	
7079.46	0.03	0.07	0.07	0.07	0.03	0.00	-0.10	-0.13	-0.17	-0.27	-0.27	-0.23	-0.13	
7498.94	-0.10	-0.10	-0.07	-0.03	-0.07	-0.03	-0.20	-0.23	-0.27	-0.20	-0.27	-0.10	-0.10	
7943.28	-0.30	-0.37	-0.30	-0.23	-0.33	-0.23	-0.33	-0.40	-0.37	-0.33	-0.33	-0.20	-0.17	
8413.95	-0.40	-0.37	-0.37	-0.43	-0.53	-0.43	-0.57	-0.57	-0.57	-0.50	-0.43	-0.23	-0.37	
8912.51	-0.40	-0.50	-0.37	-0.53	-0.67	-0.63	-0.70	-0.73	-0.73	-0.80	-0.73	-0.50	-0.50	
9440.61	-0.37	-0.40	-0.37	-0.50	-0.67	-0.70	-0.70	-0.83	-0.77	-0.90	-0.93	-0.77	-0.60	
10000.00	-0.13	-0.20	-0.27	-0.43	-0.57	-0.57	-0.77	-0.83	-0.77	-0.90	-0.97	-0.90	-0.70	
10592.54	-0.20	-0.20	-0.17	-0.40	-0.47	-0.47	-0.70	-0.83	-0.83	-0.83	-0.97	-0.87	-0.70	
11220.18	-0.47	-0.43	-0.37	-0.43	-0.53	-0.47	-0.70	-0.90	-0.77	-0.80	-0.77	-0.90	-0.67	
11885.02	-0.67	-0.73	-0.63	-0.60	-0.73	-0.57	-0.83	-0.90	-0.83	-0.87	-0.73	-0.70	-0.70	
12589.25	-0.57	-0.73	-0.83	-0.87	-0.97	-0.97	-1.00	-1.00	-1.00	-1.17	-1.07	-0.90	-0.90	
13335.21	-0.70	-0.67	-0.63	-0.83	-1.00	-1.17	-1.10	-1.07	-1.07	-1.37	-1.53	-1.20	-1.13	
14125.38	-0.40	-0.50	-0.57	-0.60	-0.90	-1.00	-1.00	-1.20	-1.17	-1.37	-1.63	-1.47	-1.20	
14962.36	-0.70	-0.73	-0.53	-0.73	-0.97	-0.90	-1.10	-1.33	-1.23	-1.50	-1.53	-1.43	-1.13	
15848.93	-0.90	-0.90	-0.97	-1.03	-1.27	-1.13	-1.30	-1.60	-1.37	-1.57	-1.37	-1.40	-1.17	
16788.04	-0.90	-1.07	-1.00	-1.30	-1.33	-1.47	-1.50	-1.53	-1.40	-1.70	-1.77	-1.43	-1.43	
17782.79	-0.87	-0.93	-0.93	-1.10	-1.33	-1.53	-1.70	-1.57	-1.67	-1.73	-2.30	-2.00	-1.70	
18836.49	-0.90	-1.10	-0.90	-1.10	-1.43	-1.43	-1.70	-1.83	-1.80	-1.83	-2.13	-2.27	-1.77	
19952.62	-1.27	-1.30	-1.13	-1.47	-1.73	-1.67	-2.07	-2.30	-1.97	-2.23	-2.13	-1.97	-1.67	

Table A-18 Directional Response, 3 1/2" Windscreen

Frequency Response

The following data was taken using the Larson Davis Model 831 Sound Level Meter with a PRM831 preamplifier at degrees increasing by 10, starting with 0° and rotating to 250°. The frequency was measured in Hertz and ranged from ~200 Hz to 20K Hz. The frequency response is testing the

response on the SLM case which is the same for the Model 831 as the LxT1 and LxT2 sound level meters.

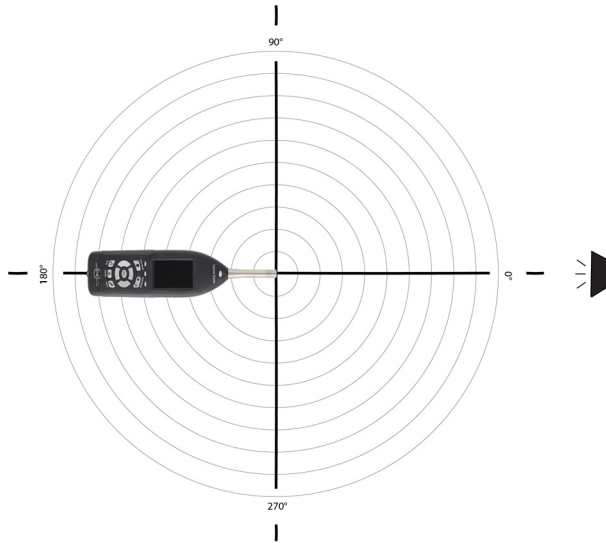

FIGURE A-2 Plane Parallel To Display Screen

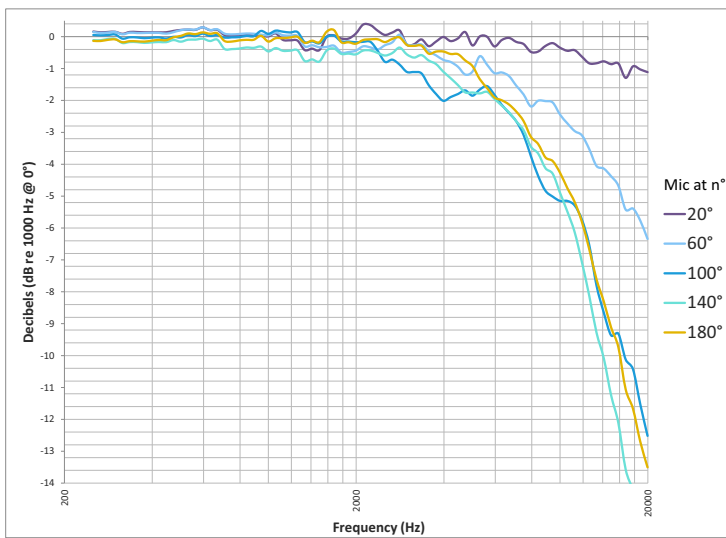

FIGURE A-3 Model 831 with 377B02 Microphone

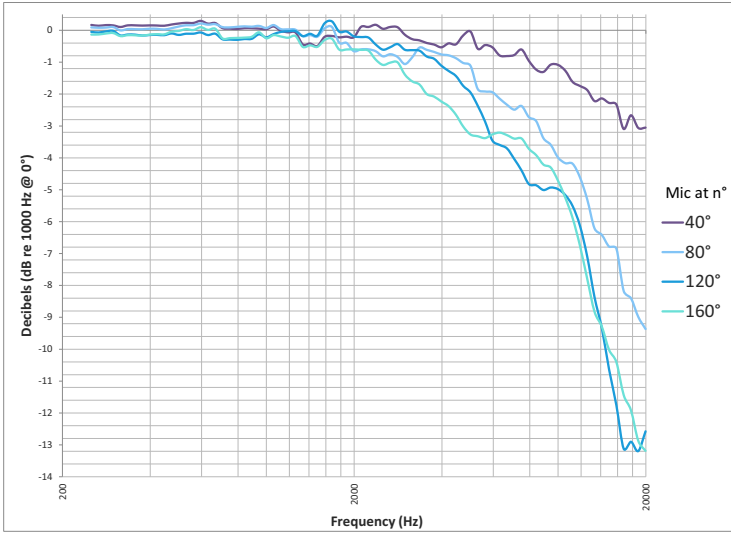

FIGURE A-4 Model 831 with 377B02 Microphone

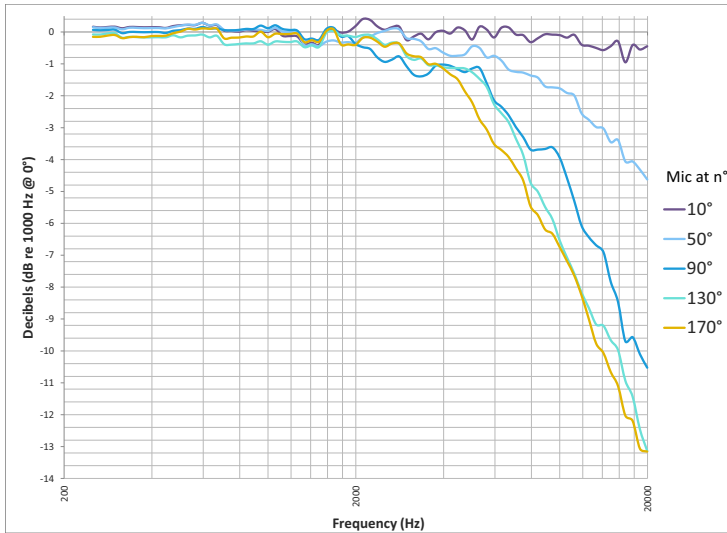

FIGURE A-5 Model 831 with 377B02 Microphone

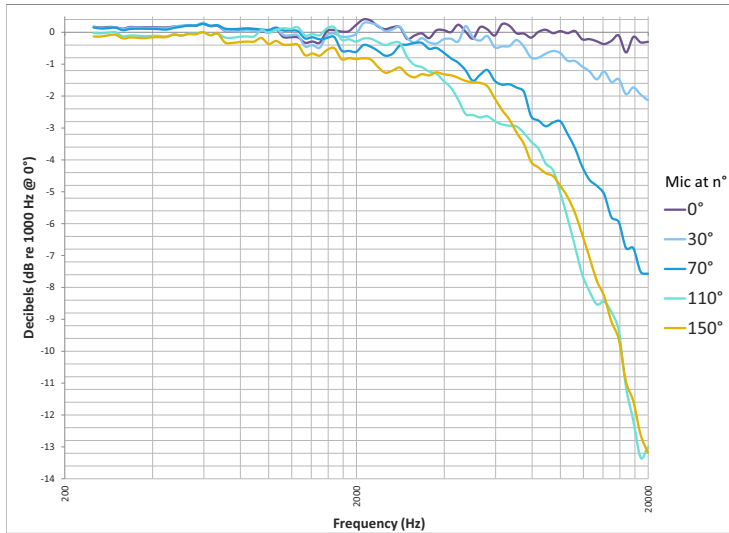

FIGURE A-6 Model 831 with 377B02 Microphone

Directional Characteristics

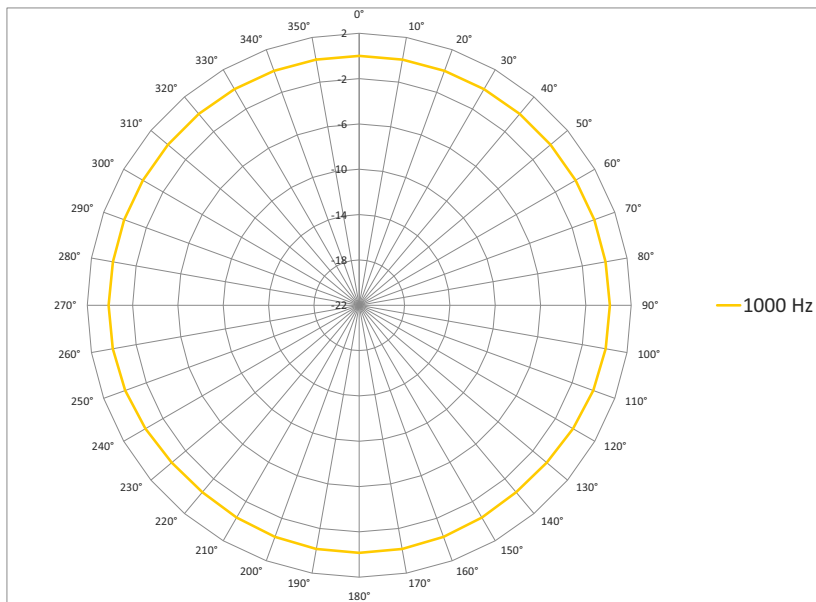

FIGURE A-7 Model 831 with 377B02: 1000 Hz

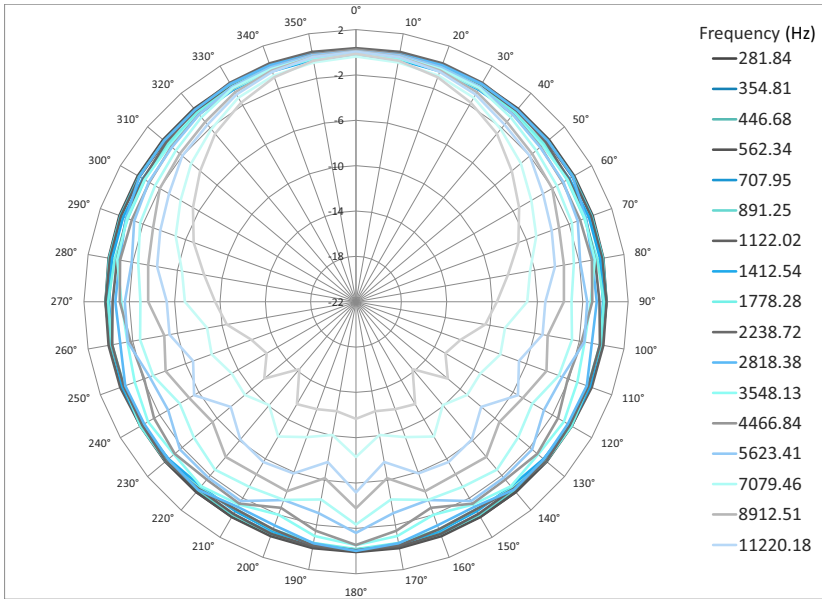

FIGURE A-8 Model 831 with 377B02

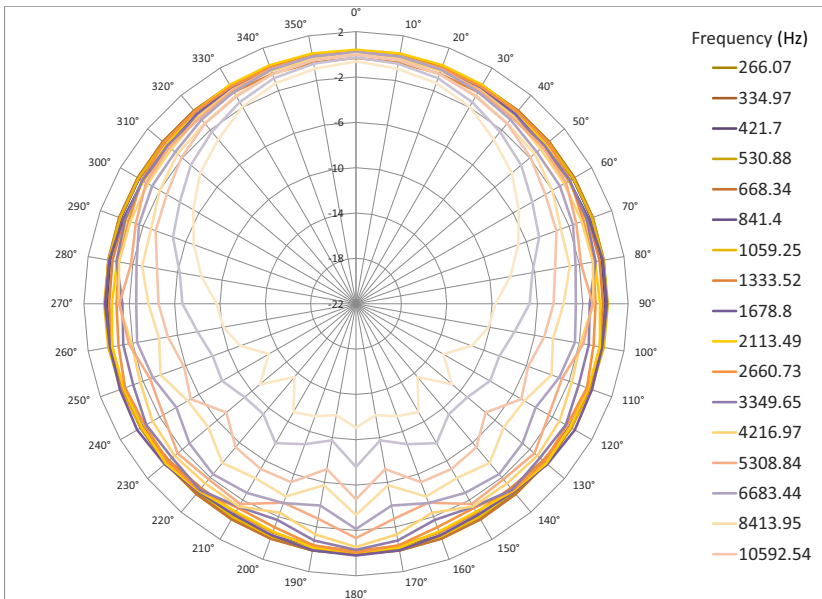

FIGURE A-9 Model 831 with 377B02 Microphone

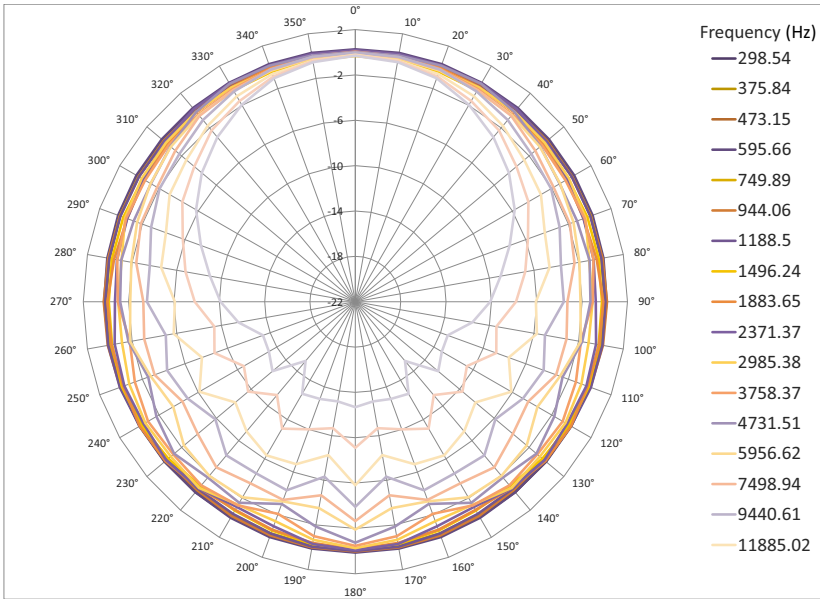

FIGURE A-10 Model 831 with 377B02

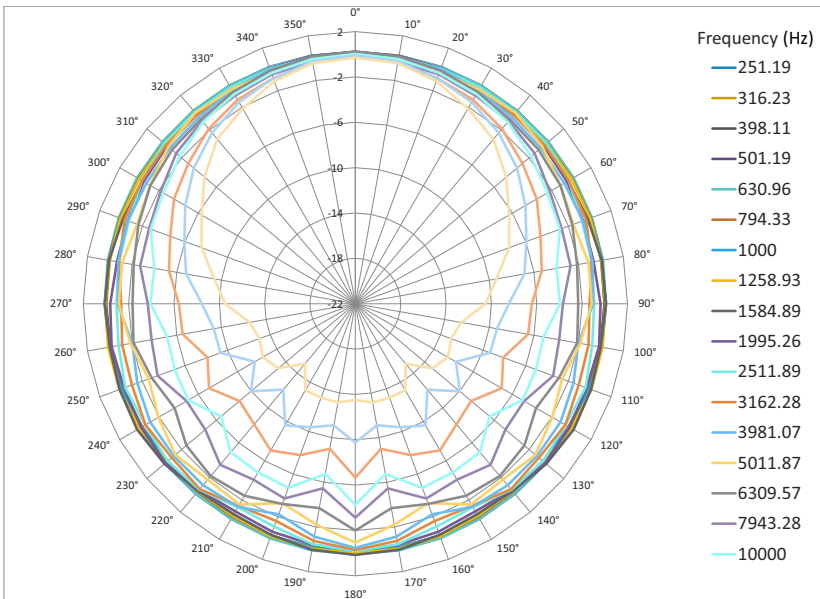

FIGURE A-11 Model 831 with 377B02 Microphone

Plane Perpendicular to Display Screen

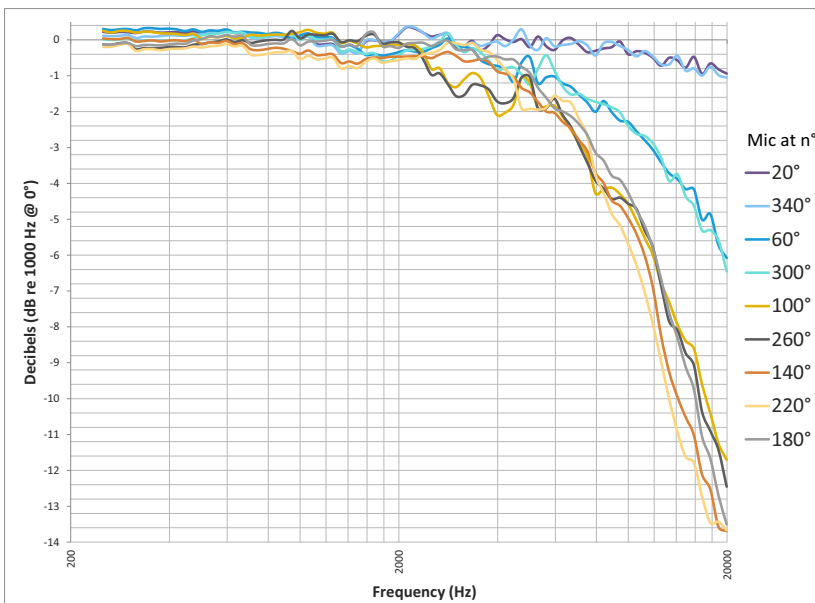
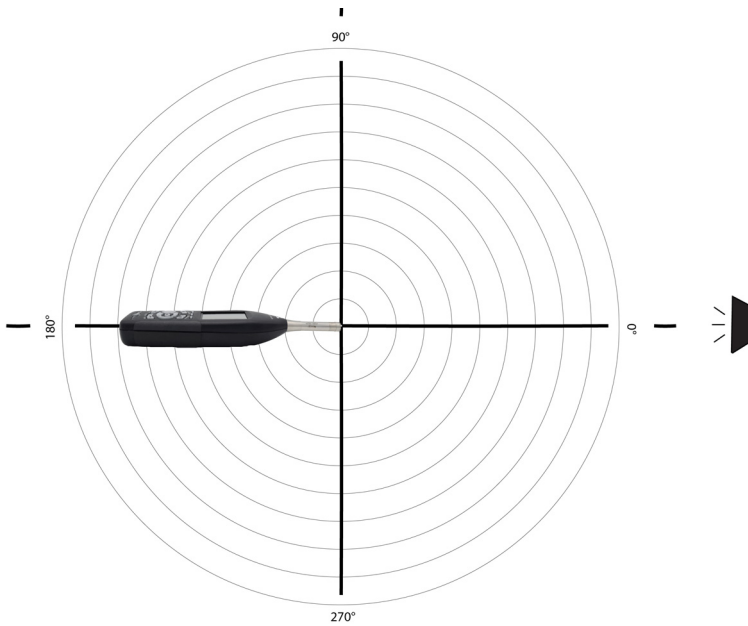

FIGURE A-12 Model 831 with 377B02 Microphone

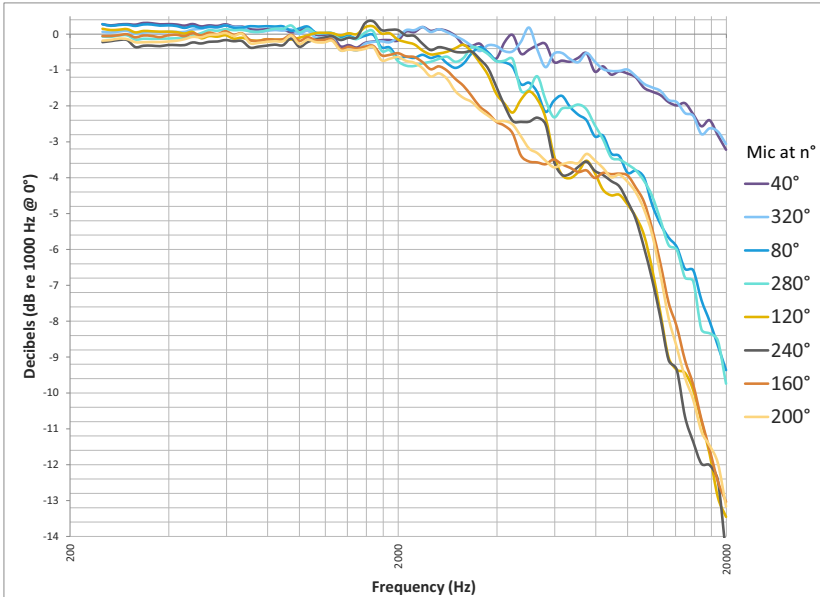

FIGURE A-13 Model 831 with 377B02 Microphone

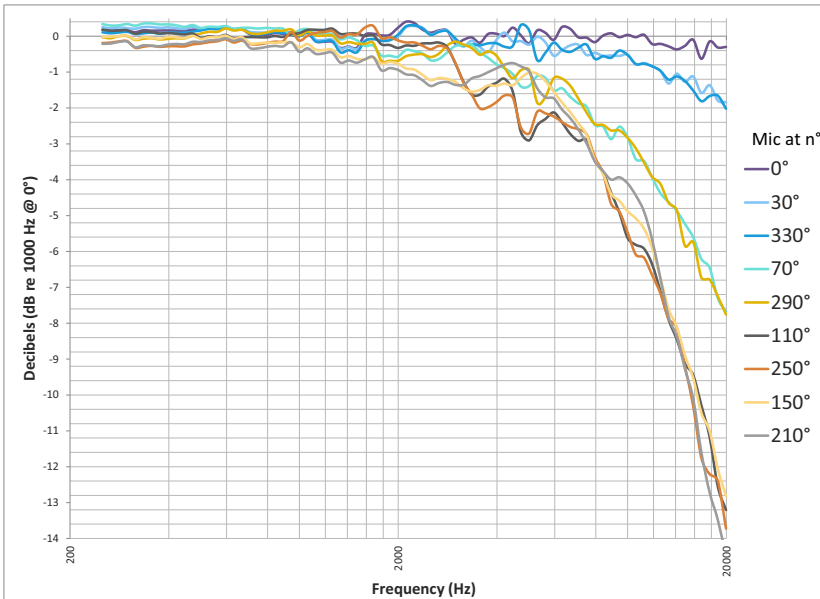

FIGURE A-14 Model 831 with 377B02 Microphone

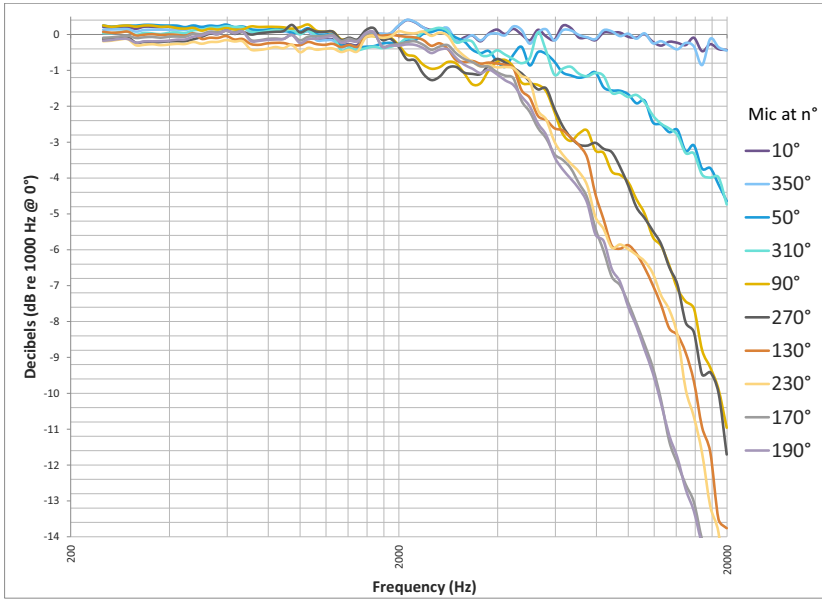

FIGURE A-15 Model 831 with 377B02 Microphone

Directional Characteristics

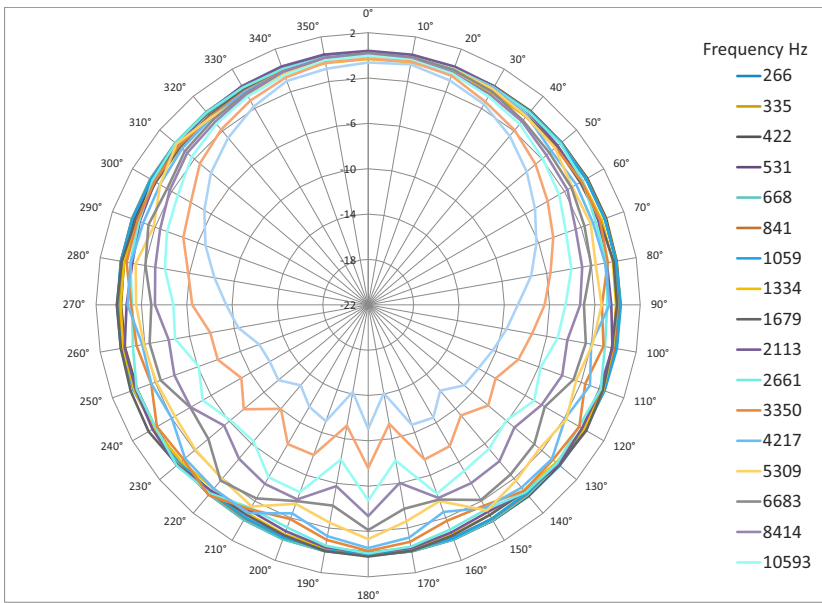

FIGURE A-16 Model 831 with 377B02 Microphone

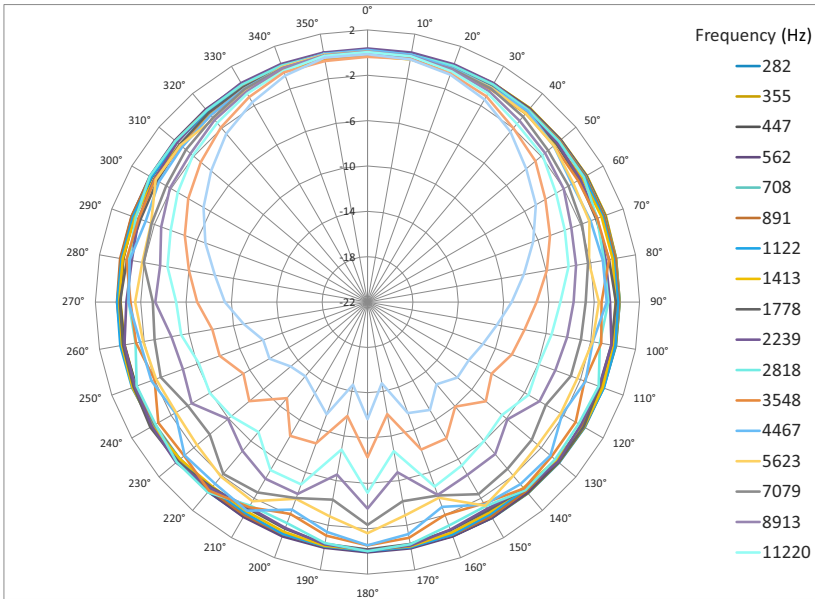

FIGURE A-17 Model 831 with 377B02 Microphone

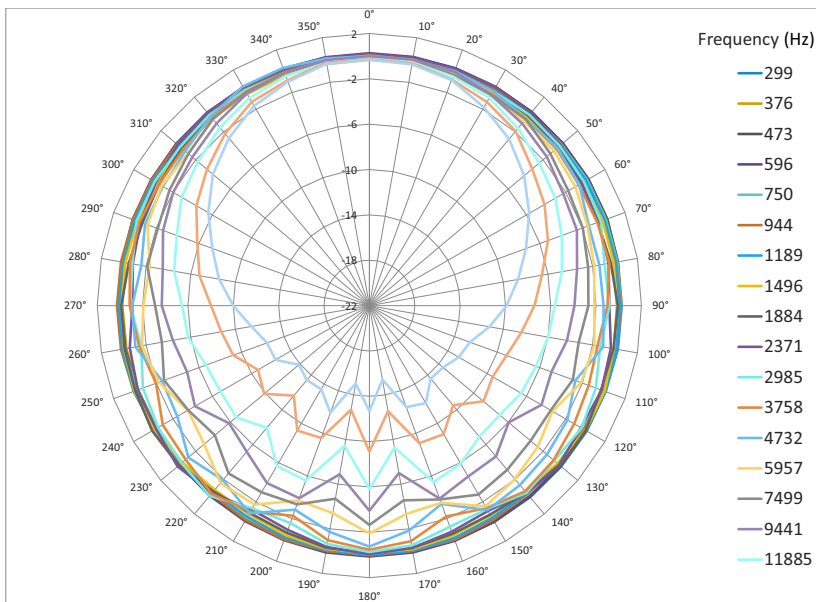

FIGURE A-18 Model 831 with 377B02 Microphone

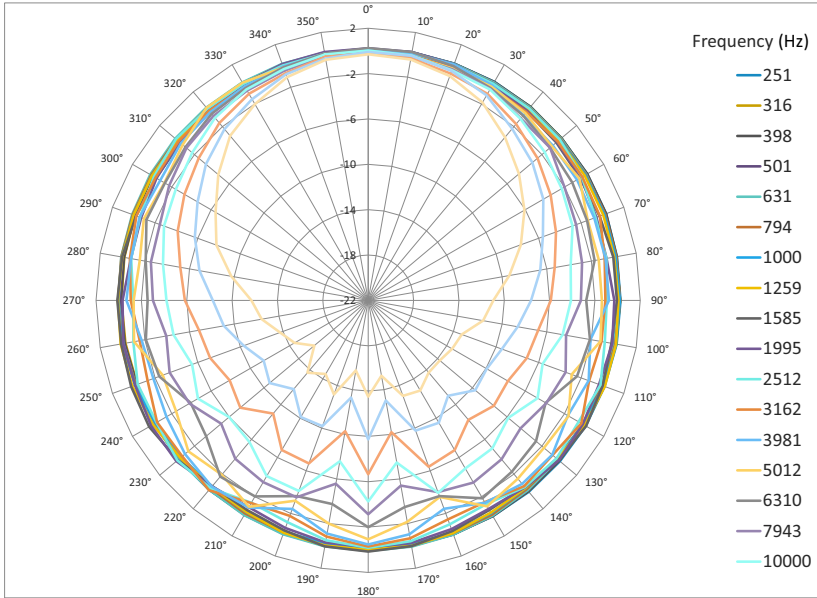

FIGURE A-19 Model 831 with 377B02 Microphone

Random Incidence

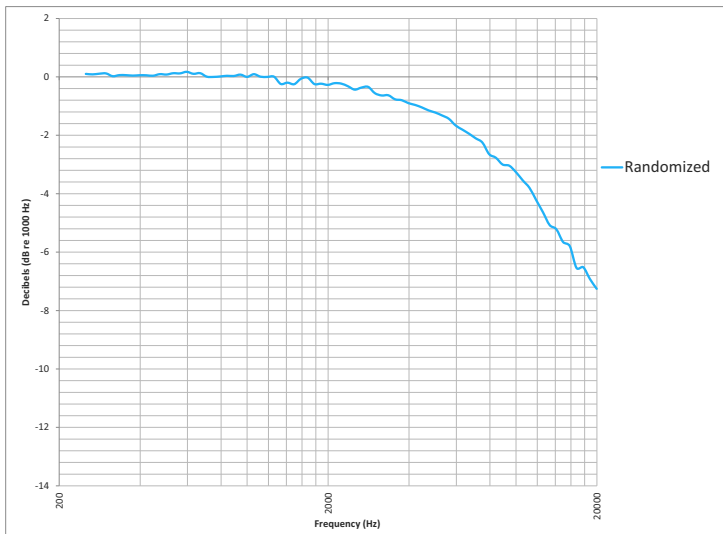

FIGURE A-20 Model 831 with 377B02 Microphone: Random Incidence

Noise Levels

The noise of the LxT includes contributions from the following components:

- Instrument and preamplifier
- Microphone

In the following sections, the noise levels are presented as a function of frequency. Graphic data is presented for both Normal and Low ranges, while the tabular data are for Low range only, but they include A-, C-, and Z-weighted broadband noise level data.

LxT1, PRMLxT1 with 377B02

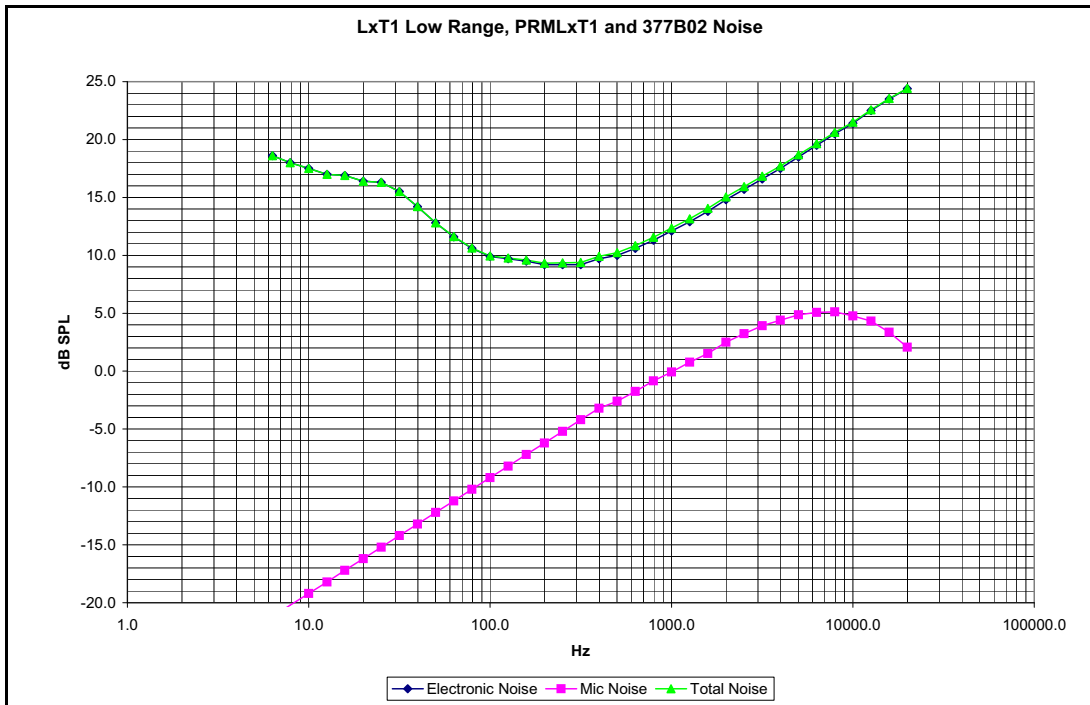

FIGURE A-21 Noise: LxT1, 377B02, PRMLxT1; Low Range

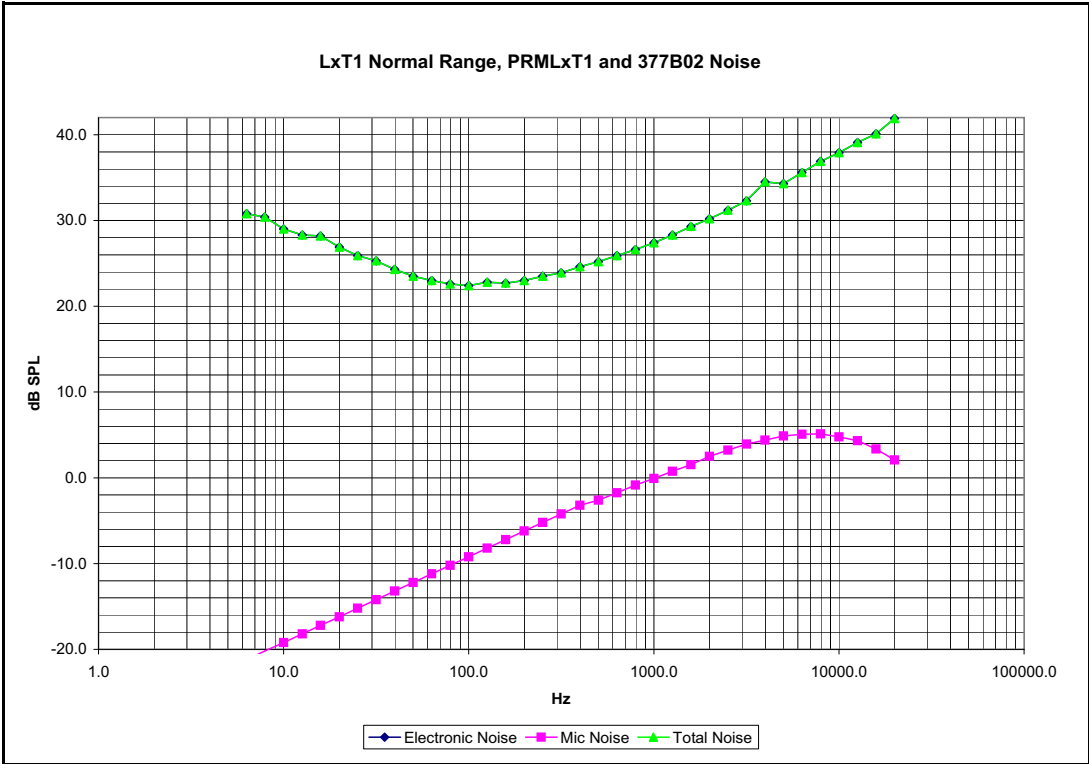

FIGURE A-22 Noise: LxT1, 377B02, PRMLxT1; Normal Range

17-Nov-05

377B02, PRMLxT1 and LxT1 Noise

Frequency Hz	LxT1 & PRMLxT1 Noise dB SPL	377B02 Noise dB SPL	LxT1, PRMLxT1 and 377B02 Noise dB SPL
6.3	18.6	-21.2	18.6
7.9	18.0	-20.2	18.0
10.0	17.5	-19.2	17.5
12.6	17.0	-18.2	17.0
15.8	16.9	-17.2	16.9
20.0	16.4	-16.2	16.4
25.1	16.3	-15.2	16.3
31.6	15.5	-14.2	15.5
39.8	14.2	-13.2	14.2
50.1	12.8	-12.2	12.8
63.1	11.6	-11.2	11.6
79.4	10.6	-10.2	10.6
100.0	9.9	-9.2	10.0
125.9	9.7	-8.2	9.8
158.5	9.5	-7.2	9.6
199.5	9.2	-6.2	9.3
251.2	9.2	-5.2	9.4
316.2	9.2	-4.2	9.4
398.1	9.7	-3.2	9.9
501.2	10.0	-2.6	10.2
631.0	10.6	-1.8	10.8
794.3	11.3	-0.8	11.6
1000.0	12.1	-0.1	12.4
1258.9	12.9	0.8	13.2
1584.9	13.8	1.5	14.0
1995.3	14.8	2.5	15.0
2511.9	15.7	3.2	15.9
3162.3	16.6	3.9	16.8
3981.1	17.5	4.4	17.7
5011.9	18.5	4.9	18.7
6309.6	19.5	5.1	19.7
7943.3	20.5	5.1	20.6
10000.0	21.4	4.8	21.5
12589.3	22.5	4.3	22.6
15848.9	23.5	3.4	23.5
19952.6	24.4	2.1	24.4
Awt	29.1	16.7	29.3
Cwt	28.9	17.8	29.2
Zwt	33.6	22.9	34.0

Table A-19 Noise; LxT1, PRMLxT1 with 377B02; Low Range

LxT1, PRMLxT1L with 377B02

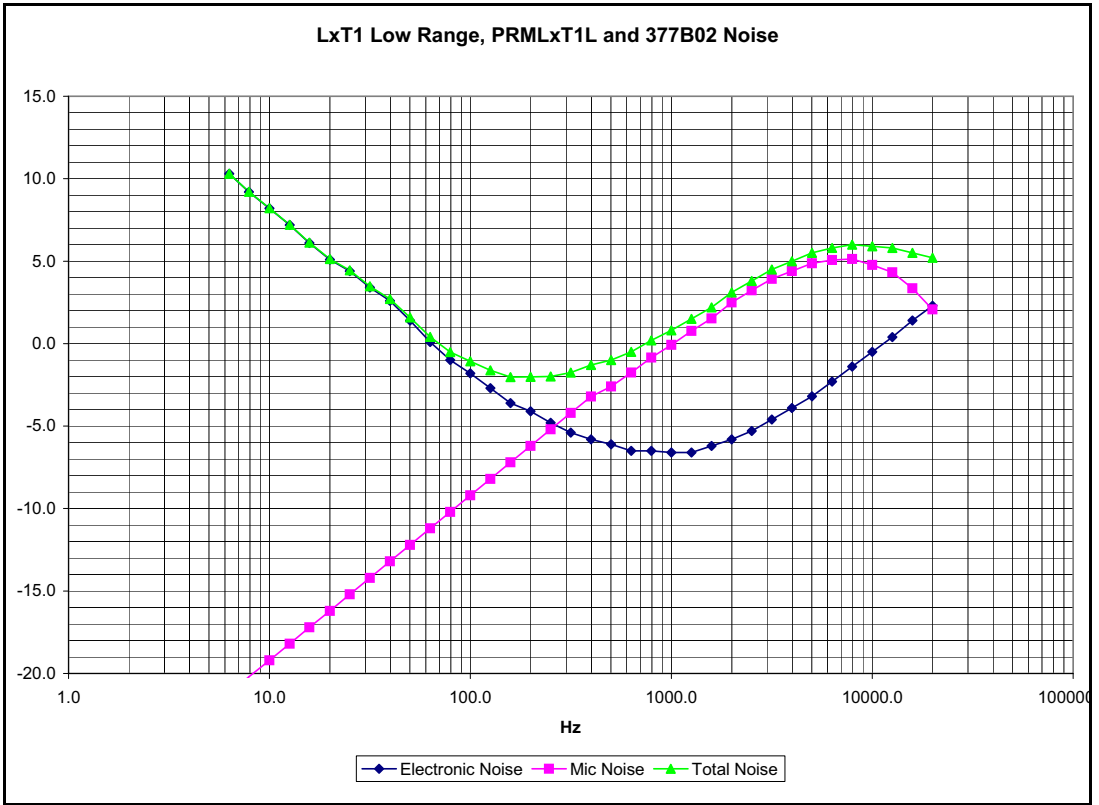

FIGURE A-23 Noise: LxT1, 377B02, PRMLxT1L; Low Range

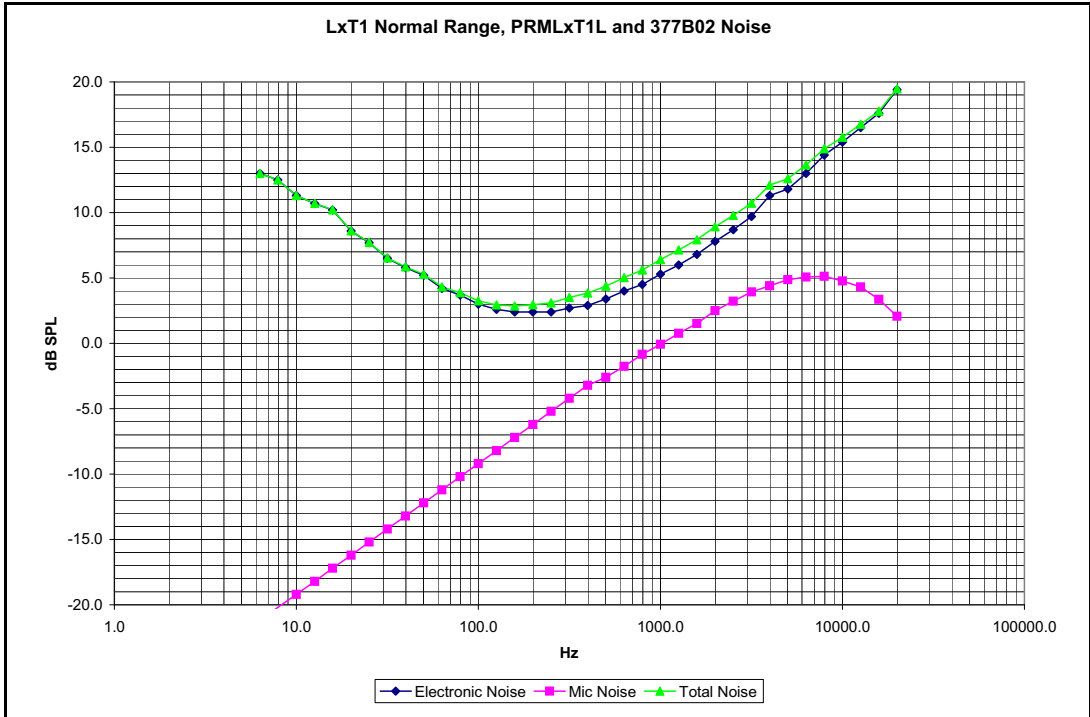

FIGURE A-24 Noise: LxT1, 377B02, PRMLxT1L; Normal Range

377B02, PRMLxT1L and LxT1 Noise

Frequency Hz	LxT1 & PRMLxT1L	377B02	LxT1, PRMLxT1L and 377B02
	Noise dB SPL	Noise dB SPL	Noise dB SPL
6.3	10.3	-21.2	10.3
7.9	9.2	-20.2	9.2
10.0	8.2	-19.2	8.2
12.6	7.2	-18.2	7.2
15.8	6.1	-17.2	6.1
20.0	5.1	-16.2	5.1
25.1	4.4	-15.2	4.4
31.6	3.4	-14.2	3.5
39.8	2.6	-13.2	2.7
50.1	1.4	-12.2	1.6
63.1	0.1	-11.2	0.4
79.4	-1.0	-10.2	-0.5
100.0	-1.8	-9.2	-1.1
125.9	-2.7	-8.2	-1.6
158.5	-3.6	-7.2	-2.0
199.5	-4.1	-6.2	-2.0
251.2	-4.8	-5.2	-2.0
316.2	-5.4	-4.2	-1.8
398.1	-5.8	-3.2	-1.3
501.2	-6.1	-2.6	-1.0
631.0	-6.5	-1.8	-0.5
794.3	-6.5	-0.8	0.2
1000.0	-6.6	-0.1	0.8
1258.9	-6.6	0.8	1.5
1584.9	-6.2	1.5	2.2
1995.3	-5.8	2.5	3.1
2511.9	-5.3	3.2	3.8
3162.3	-4.6	3.9	4.5
3981.1	-3.9	4.4	5.0
5011.9	-3.2	4.9	5.5
6309.6	-2.3	5.1	5.8
7943.3	-1.4	5.1	6.0
10000.0	-0.5	4.8	5.9
12589.3	0.4	4.3	5.8
15848.9	1.4	3.4	5.5
19952.6	2.3	2.1	5.2
Awt	8.0	16.7	17.3
Cwt	11.7	17.8	18.8
Zwt	18.0	22.9	24.1

Table A-20 Noise; LxT1 with PRMLxT1L and 377B02; Low Range

LxT2, PRMLxT2B with 375B02

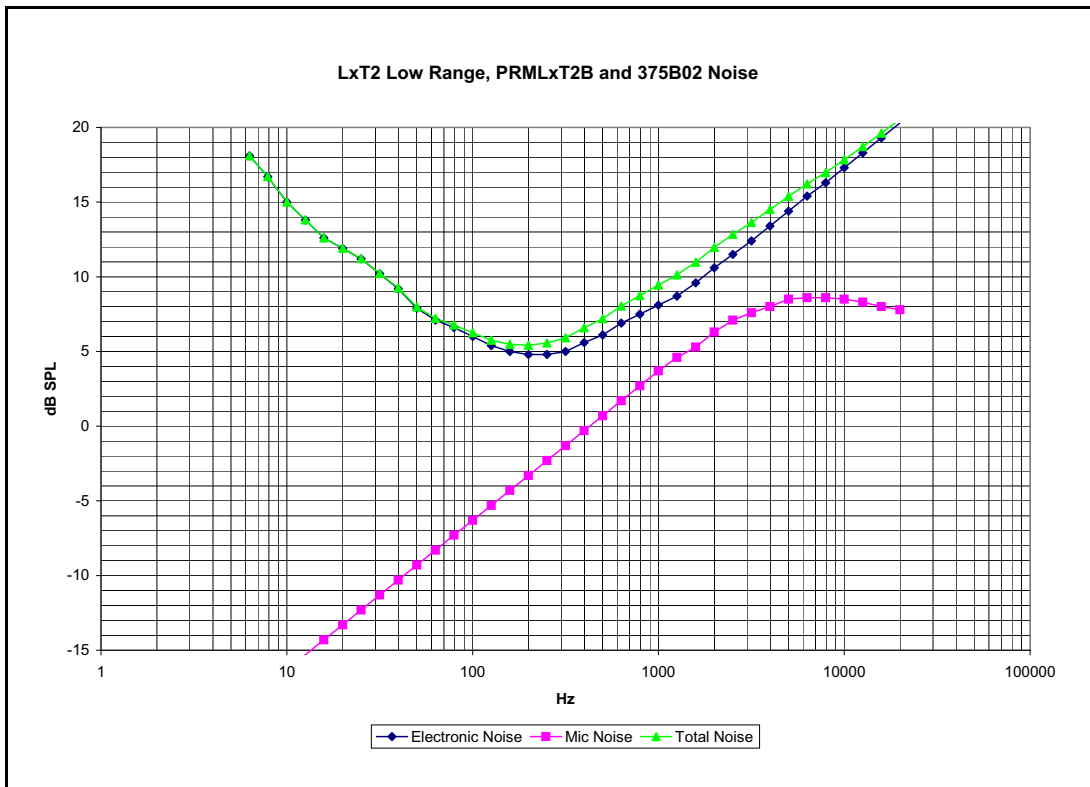

FIGURE A-25 Noise: LxT2, 375B02, PRMLxT2B; Low Range

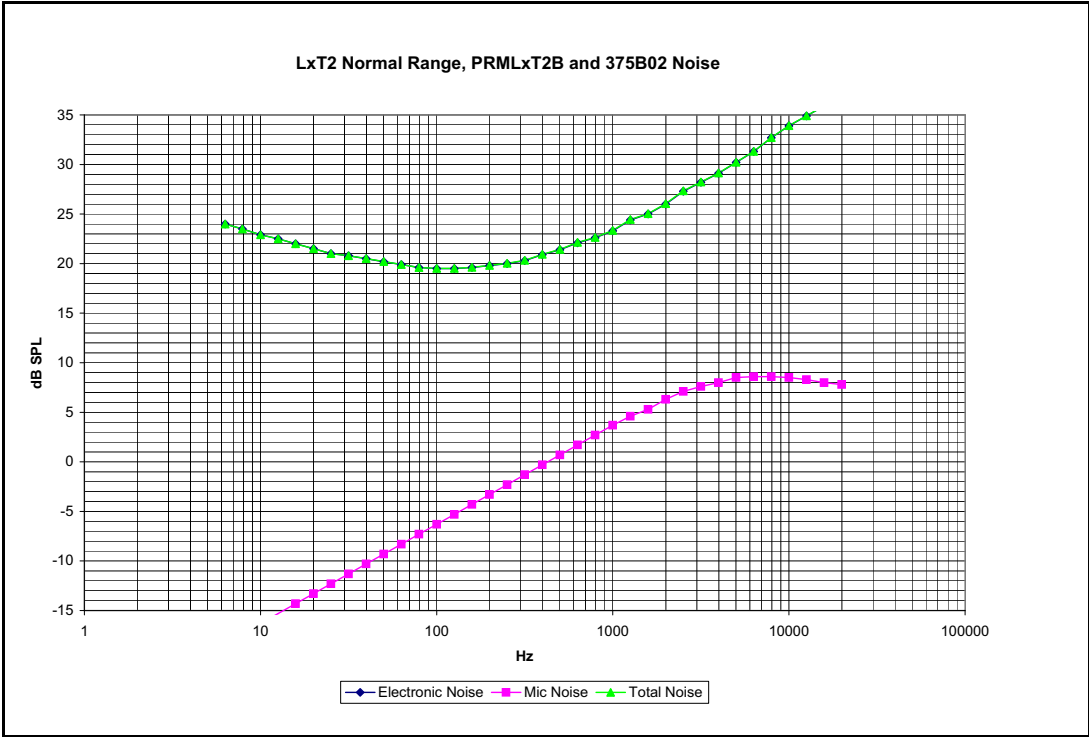

FIGURE A-26 Noise: LxT2, 375B02, PRMLxT2B; Normal Range

375B02, PRMLxT2B and LxT2 Noise

Low Range

Frequency Hz	LxT2 & PRMLxT2B Noise dB SPL	375B02 Noise dB SPL	LxT2, PRMLxT2B and 375B02 Noise dB SPL
6.3	18.1	-18.3	18.1
7.9	16.7	-17.3	16.7
10.0	15.0	-16.3	15.0
12.6	13.8	-15.3	13.8
15.8	12.6	-14.3	12.6
20.0	11.9	-13.3	11.9
25.1	11.2	-12.3	11.2
31.6	10.2	-11.3	10.2
39.8	9.2	-10.3	9.2
50.1	7.9	-9.3	8.0
63.1	7.1	-8.3	7.2
79.4	6.6	-7.3	6.8
100.0	6.0	-6.3	6.2
125.9	5.4	-5.3	5.8
158.5	5.0	-4.3	5.5
199.5	4.8	-3.3	5.4
251.2	4.8	-2.3	5.6
316.2	5.0	-1.3	5.9
398.1	5.6	-0.3	6.6
501.2	6.1	0.7	7.2
631.0	6.9	1.7	8.0
794.3	7.5	2.7	8.7
1000.0	8.1	3.7	9.4
1258.9	8.7	4.6	10.1
1584.9	9.6	5.3	11.0
1995.3	10.6	6.3	12.0
2511.9	11.5	7.1	12.8
3162.3	12.4	7.6	13.6
3981.1	13.4	8.0	14.5
5011.9	14.4	8.5	15.4
6309.6	15.4	8.6	16.2
7943.3	16.3	8.6	17.0
10000.0	17.3	8.5	17.8
12589.3	18.3	8.3	18.7
15848.9	19.3	8.0	19.6
19952.6	20.3	7.8	20.5

Table A-21 Noise; LxT2, PRMLxT2B with 375B02; Low Range

LxT2, PRMLxT2L with 375B02

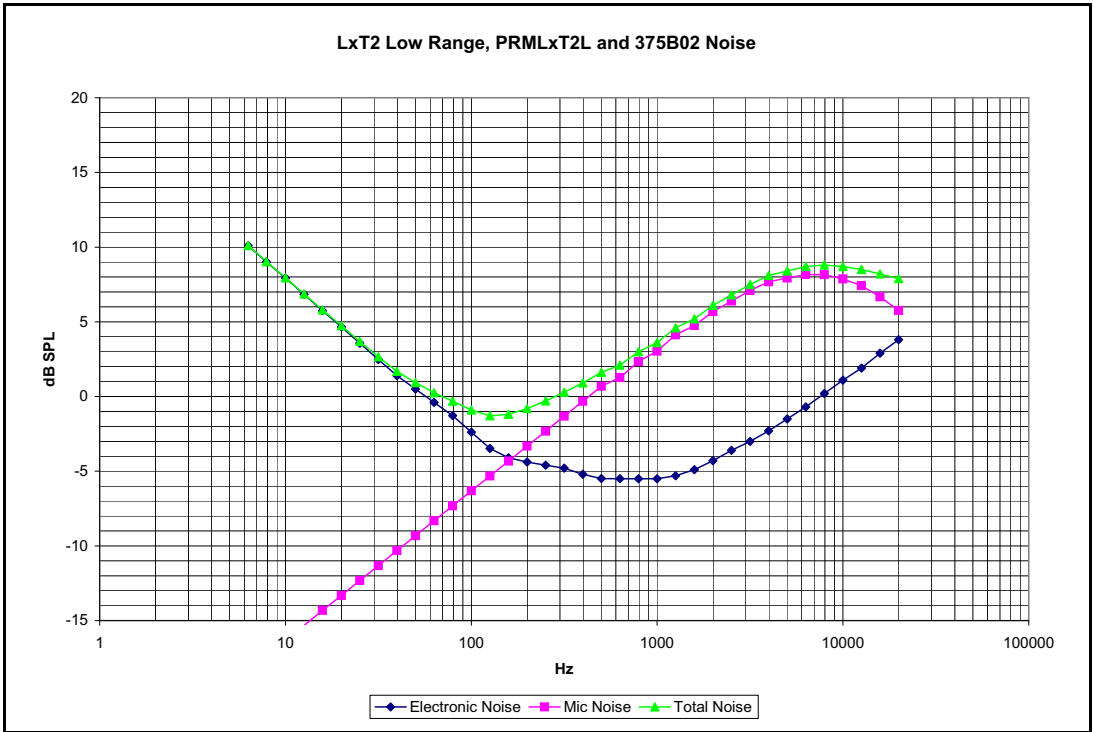

FIGURE A-27 Noise LxT2, 375B02, PRMLxT2L; Low Range

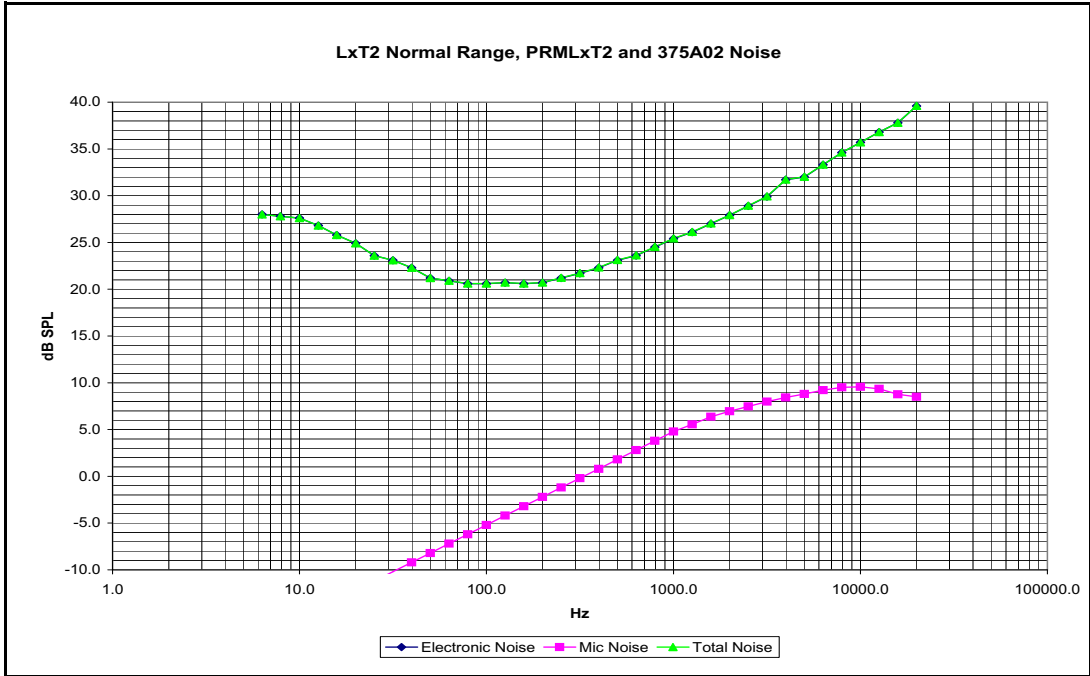

FIGURE A-28 Noise: LxT2, 375B02, PRMLxT2L; Normal Range

375B02, PRMLxT2L and LxT2 Noise			Low Range
Frequency	LxT2 & PRMLxT2L Noise	375B02 Noise	LxT2, PRMLxT2L and 375B02 Noise
Hz	dB SPL	dB SPL	dB SPL
6.3	10.1	-18.3	10.1
7.9	9.0	-17.3	9.0
10.0	7.9	-16.3	7.9
12.6	6.8	-15.3	6.9
15.8	5.8	-14.3	5.8
20.0	4.7	-13.3	4.7
25.1	3.6	-12.3	3.7
31.6	2.5	-11.3	2.7
39.8	1.4	-10.3	1.7
50.1	0.5	-9.3	0.9
63.1	-0.4	-8.3	0.3
79.4	-1.3	-7.3	-0.3
100.0	-2.4	-6.3	-0.9
125.9	-3.5	-5.3	-1.3
158.5	-4.1	-4.3	-1.2
199.5	-4.4	-3.3	-0.8
251.2	-4.6	-2.3	-0.3
316.2	-4.8	-1.3	0.3
398.1	-5.2	-0.3	0.9
501.2	-5.5	0.7	1.6
631.0	-5.5	1.3	2.1
794.3	-5.5	2.3	3.0
1000.0	-5.5	3.0	3.6
1258.9	-5.3	4.1	4.6
1584.9	-4.9	4.8	5.2
1995.3	-4.3	5.7	6.1
2511.9	-3.6	6.4	6.8
3162.3	-3.0	7.1	7.5
3981.1	-2.3	7.7	8.1
5011.9	-1.5	7.9	8.4
6309.6	-0.7	8.2	8.7
7943.3	0.2	8.2	8.8
10000.0	1.1	7.9	8.7
12589.3	1.9	7.4	8.5
15848.9	2.9	6.7	8.2
19952.6	3.8	5.8	7.9
Awt	9.4	18.0	18.5
Cwt	12.0	16.9	18.1
Zwt	17.8	18.7	21.3

Table A-22 Noise; LxT2, PRMLxT2L with 375B02; Low Range

Microphone Preamp Specifications

The general specifications for the LxT microphone preamplifiers are shown in Table A-23

Preamp Type	Mic. Type	Nominal Microphone Sensitivity mV/Pa	Nominal Preamp Attenuation dB	Nominal Sensitivity at LxT Input		Sensitivity Limits	
				mV/Pa	dB re. 1V/PA	High, dB re. 1V/PA	Low, dB re. 1V/PA
PRMLxT1	377B02	50.0	23.30	3.42	-49.3	-45.6	-55.6
PRMLxT1	377C20	50.0	23.30	3.42	-49.3	-45.6	-55.6
PRMLxT1	377C01	2.0	27.30	0.058	-84.7	-81.0	-91.0
PRMLxT1	377C10	1.0	27.03	0.023	-92.7	-89.0	-99.0
PRMLxT1L	377B02	50.0	1.82	40.5	-27.8	-24.1	-34.1
PRMLxT1L	377C20	50.0	1.82	40.5	-27.8	-24.1	-34.1
PRMLxT1L	377C01	2.0	5.45	1.32	-57.6	-53.9	-63.9
PRMLxT1L	377C10	1.0	5.45	0.59	-64.5	-60.8	-70.8
PRMLxT2B	375B02	35.5	19.08	3.98	-48.0	-44.3	-54.3
PRMLxT2L	375B02	35.5	1.45	27.90	-31.1	-27.4	-37.4

Table A-23 LxT Preamplifiers

The following sections present the specifications for the four different microphone preamplifiers which can be used with the LxT.

Model PRMLxT1

The Larson Davis PRMLxT1 is a prepolarized microphone preamplifier for use with a Larson Davis LxT Sound Level Meter. It requires very little supply current and will drive 200 feet of cable. The preamplifier operates over wide temperature and humidity ranges. It has a built in attenuation of 23 dB for use with 50 mV/Pa sensitivity microphones up to 140 dBSPL.

Specifications

Unless otherwise stated, all electroacoustic values are at 23 °C, 50% RH, 7.5 Volt supply, 3 m (10') cable and equivalent microphone of 18pF.

Frequency response

with respect to the response at 1 kHz with 13 Volts rms input and 18 pF equivalent microphone.

4 Hz to 10 Hz +0.1, -0.2 dB

12.6 Hz to 40 kHz +0.1, -0.1 dB

Lower -3 dB limit < 1 Hz

Attenuation

22.8 dB (typical)

Input Impedance

10 G Ohm // 5.3 pF

Output Impedance

50 Ohm

Maximum Output

2.8 V_{pp}

143 dB peak for microphones with 50 mV/Pa sensitivity

Maximum Output Current

10 mA peak

Distortion

Harmonics <-58 dBC with 0.7 Volt rms output at 1 kHz

Output Slew Rate

2 V/ μ S (typical)

Electronic Noise

with 18pF equivalent microphone

1.1 μ V typical A-weighted (1.4 μ V max)

1.6 μ V typical Flat 20 Hz to 20 kHz (2.1 μ V max)

Power Supply Voltage

6 to 10 Volts

DC Output Level

~1/2 power supply voltage

Power Supply Current

1.3 mA typical

Temperature Sensitivity

< \pm 0.1 dB from -10° to +50°C (14° to +122°F) operating range to 60°C (140°F)

Humidity Sensitivity

≤ 0.1 dB from 0 to 90% RH, non-condensing at 40°C (104°F)

Dimensions

12.7 mm diameter x 73 mm length (0.50" dia x 2.88" length)

Microphone Thread

11.7 mm - 60 UNS (0.4606 - 60 UNS)

Cable Driving Capability

LxT SLM (1 V rms output signal)

To 20 kHz with 200'(61 m) cable

Output Connector

Switchcraft[®] TA5M

5-Pin male

Pin	Signal
1	Signal Ground
2	Signal Output
3	Power Supply + 7 Volts
4	Preamp sense
5	No Connection
Shell	Connect to preamp housing

Table A-24 Output Connector

Compatibility

Use with Larson Davis 377B02 or any ½" prepolarized microphone having about 50 mV/Pa sensitivity and meeting the mechanical requirements of IEC 61094-4. It can also be used with a ¼" prepolarized microphone using a Larson Davis ADP043 adapter.

**Preamplifier Model: PRMLxT1 Serial Number: 0163
Certificate of Electrical Conformance**

Frequency response of this model PRMLxT1 preamplifier was tested at a level of 13.858 Vrms with 18pF microphone capacitance and driving a short cable. Output level at 1kHz is 0.9442 Vrms (-0.499 dBV), uncertainty 0.045 dB. Output is 3.511 V DC, uncertainty 0.001. Results are displayed relative to the level at 1kHz.

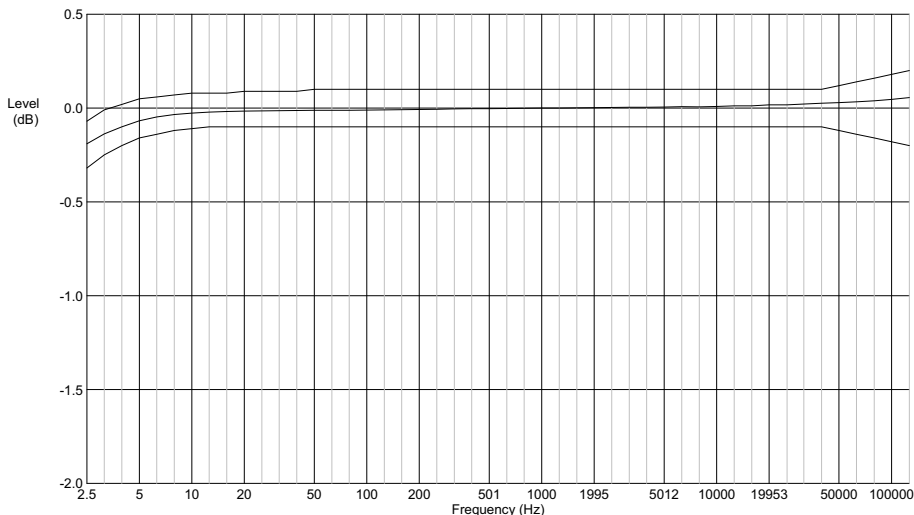

Freq (Hz)	Measured (dB)	Uncert (dB)	Tolerance (dB)	Freq (Hz)	Measured (dB)	Uncert (dB)	Tolerance (dB)
2.51	-0.19	0.075	-0.07, -0.32	630.96	-0.00	0.016	+0.10, -0.10
3.16	-0.14	0.058	-0.01, -0.25	794.33	-0.00	0.016	+0.10, -0.10
3.98	-0.10	0.058	+0.02, -0.20	1000.00	0.00	0.016	+0.10, -0.10
5.01	-0.07	0.036	+0.05, -0.16	1258.90	0.00	0.016	+0.10, -0.10
6.31	-0.05	0.036	+0.06, -0.14	1584.90	0.00	0.016	+0.10, -0.10
7.94	-0.03	0.036	+0.07, -0.12	1995.30	0.00	0.016	+0.10, -0.10
10.00	-0.03	0.016	+0.08, -0.11	2511.90	0.00	0.016	+0.10, -0.10
12.59	-0.02	0.016	+0.08, -0.10	3162.30	0.00	0.016	+0.10, -0.10
15.85	-0.02	0.016	+0.08, -0.10	3981.10	0.01	0.016	+0.10, -0.10
19.95	-0.02	0.016	+0.09, -0.10	5011.90	0.01	0.016	+0.10, -0.10
25.12	-0.02	0.016	+0.09, -0.10	6309.60	0.01	0.016	+0.10, -0.10
31.62	-0.01	0.016	+0.09, -0.10	7943.30	0.01	0.016	+0.10, -0.10
39.81	-0.01	0.016	+0.09, -0.10	10000.00	0.01	0.016	+0.10, -0.10
50.12	-0.01	0.016	+0.10, -0.10	12589.00	0.01	0.016	+0.10, -0.10
63.10	-0.01	0.016	+0.10, -0.10	15849.00	0.01	0.016	+0.10, -0.10
79.43	-0.01	0.016	+0.10, -0.10	19953.00	0.02	0.016	+0.10, -0.10
100.00	-0.01	0.016	+0.10, -0.10	25250.00	0.02	0.022	+0.10, -0.10
125.89	-0.01	0.016	+0.10, -0.10	31500.00	0.02	0.022	+0.10, -0.10
158.49	-0.01	0.016	+0.10, -0.10	39750.00	0.03	0.022	+0.10, -0.10
199.53	-0.01	0.016	+0.10, -0.10	50000.00	0.03	0.022	+0.12, -0.12
251.19	-0.01	0.016	+0.10, -0.10	63000.00	0.03	0.047	+0.14, -0.14
316.23	-0.01	0.016	+0.10, -0.10	79500.00	0.04	0.047	+0.16, -0.16
398.11	-0.00	0.016	+0.10, -0.10	100000.00	0.05	0.047	+0.18, -0.18
501.19	-0.00	0.016	+0.10, -0.10	126000.00	0.06	0.063	+0.20, -0.20

Noise floor data: 1kHz (1/3 Octave) = 0.16 uV, -15.7 dBuV, uncertainty = 0.47 dB
 Flat (20Hz-20kHz) = 1.7 uV, 4.4 dBuV, uncertainty = 0.47 dB
 Awt = 1.0 uV, 0.3 dBuV, uncertainty = 0.46 dB

Uncertainties are given as expanded uncertainty at ~95% confidence interval (k = 2).

Technician: Ron Harris Test Date: 30SEP2005

FIGURE A-29 Certificate of Conformance; PRMLxT1

Model PRMLxT1L

The Larson Davis PRMLxT1L is a prepolarized microphone preamplifier for use with Larson Davis LxT Sound Level Meters. It requires very little supply current and will drive 200 feet of cable. The preamplifier operates over wide temperature and humidity ranges. It is for use with 50 mV/Pa sensitivity microphones up to 118 dBSPL.

Specifications

Unless otherwise stated, all electroacoustic values are at 23 °C, 50% RH, 7.5 Volt supply, 3 m (10') cable and equivalent microphone of 18pF.

Frequency response

with respect to the response at 1 kHz with 1.1 Volts rms input and 18 pF equivalent microphone.

4 Hz to 10 Hz +0.1, -0.5 dB

10 Hz to 40 kHz +0.1, -0.18 dB

Lower -3 dB limit < 1.5 Hz

Attenuation

1.2 dB (typical)

Input Impedance

10 G Ohm // 3 pF

Output Impedance

50 Ohm

Maximum Output

2.8 Vpp

121 dB peak for microphones with 50 mV/Pa sensitivity

Maximum Output Current

10 mA peak

Distortion

Harmonics <-50 dBc with 0.7 Volt rms output at 1 kHz

Output Slew Rate

2 V/ μ S (typical)

Electronic Noise

with 18pF equivalent microphone

1.8 μV typical A-weighted (2.5 μV max)

3.2 μV typical Flat 20 Hz to 20 kHz (5 μV max)

Power Supply Voltage

6 to 15 Volts

DC Output Level

~1/2 power supply voltage

Power Supply Current

1.3 mA typical

Temperature Sensitivity

$<\pm 0.1$ dB from -10° to $+50^\circ\text{C}$ (14° to $+122^\circ\text{F}$) operating range to 60°C (140°F)

Humidity Sensitivity

$<\pm 0.1$ dB from 0 to 90% RH, non-condensing at 40°C (104°F)

Dimensions

12.7 mm diameter x 73 mm length (0.50" dia x 2.88" length)

Microphone Thread

11.7 mm – 60 UNS (0.4606 – 60 UNS)

Cable Driving Capability

LxT SLM (1 V rms output signal)

To 20 kHz with 200'(61 m) cable

Output Connector

Switchcraft® TA5M

5-Pin male

Pin	Signal
1	Signal Ground
2	Signal Output
3	Power Supply + 7 Volts
4	Preamp sense
5	No Connection
Shell	Connected to preamp housing

Table A-25 Output Connector

Compatibility

Use with Larson Davis 377B02 or any ½" prepolarized microphone having about 50 mV/Pa sensitivity and meeting the mechanical requirements of IEC 61094-4. It can be used with either the Larson Davis ADP043 or ADP008 adapters for ¼" or 1" prepolarized microphones. Due to continual product improvement, specifications are subject to change without notice.

**Preamplifier Model: PRMLxT1L Serial Number: 0102
Certificate of Electrical Conformance**

Frequency response of this model PRMLxT1L preamplifier was tested at a level of 1.157 Vrms with 18pF microphone capacitance and driving a short cable. Output level at 1kHz is 1.0167 Vrms (0.144 dBV), uncertainty 0.035 dB. Output is 3.664 V DC, uncertainty 0.001. Results are displayed relative to the level at 1kHz.

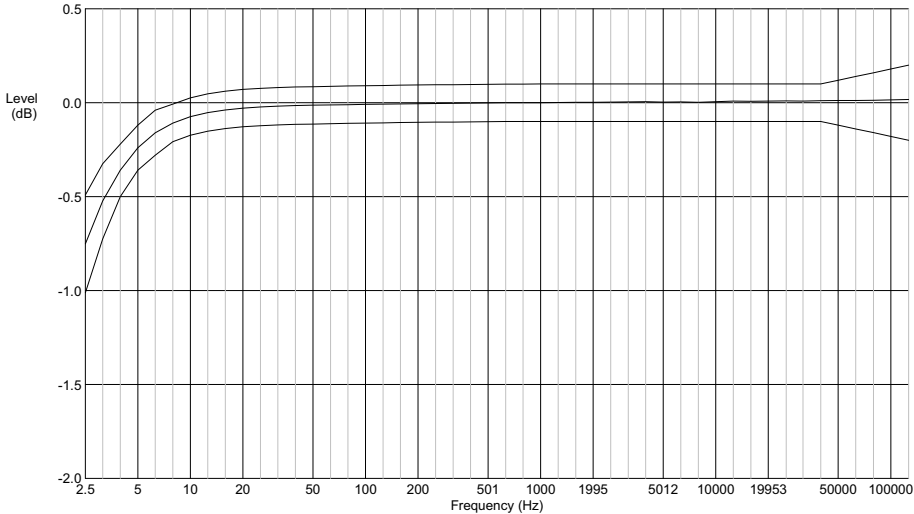

Freq (Hz)	Measured (dB)	Uncert (dB)	Tolerance (dB)	Freq (Hz)	Measured (dB)	Uncert (dB)	Tolerance (dB)
2.51	-0.75	0.075	-0.49, -1.01	630.96	-0.00	0.016	+0.10, -0.10
3.16	-0.52	0.058	-0.32, -0.73	794.33	0.00	0.016	+0.10, -0.10
3.98	-0.36	0.058	-0.22, -0.50	1000.00	0.00	0.016	+0.10, -0.10
5.01	-0.24	0.036	-0.12, -0.36	1258.90	0.00	0.016	+0.10, -0.10
6.31	-0.16	0.036	-0.04, -0.28	1584.90	0.00	0.016	+0.10, -0.10
7.94	-0.11	0.036	-0.01, -0.21	5195.30	0.00	0.016	+0.10, -0.10
10.00	-0.07	0.016	+0.03, -0.17	2511.90	0.00	0.016	+0.10, -0.10
12.59	-0.05	0.016	+0.05, -0.15	3162.30	0.00	0.016	+0.10, -0.10
15.85	-0.04	0.016	+0.06, -0.14	3981.10	0.01	0.016	+0.10, -0.10
19.95	-0.03	0.016	+0.07, -0.13	5011.90	0.00	0.016	+0.10, -0.10
25.12	-0.02	0.016	+0.08, -0.12	6309.60	0.00	0.016	+0.10, -0.10
31.62	-0.02	0.016	+0.08, -0.12	7943.30	0.00	0.016	+0.10, -0.10
39.81	-0.02	0.016	+0.08, -0.12	10000.00	0.01	0.016	+0.10, -0.10
50.12	-0.01	0.016	+0.09, -0.11	12589.00	0.01	0.016	+0.10, -0.10
63.10	-0.01	0.016	+0.09, -0.11	15849.00	0.01	0.016	+0.10, -0.10
79.43	-0.01	0.016	+0.09, -0.11	19953.00	0.01	0.016	+0.10, -0.10
100.00	-0.01	0.016	+0.09, -0.11	25250.00	0.01	0.022	+0.10, -0.10
125.89	-0.01	0.016	+0.09, -0.11	31500.00	0.01	0.022	+0.10, -0.10
158.49	-0.01	0.016	+0.09, -0.11	39750.00	0.01	0.022	+0.10, -0.10
199.53	-0.01	0.016	+0.09, -0.10	50000.00	0.01	0.022	+0.12, -0.12
251.19	-0.00	0.016	+0.10, -0.10	63000.00	0.01	0.047	+0.14, -0.14
316.23	-0.00	0.016	+0.10, -0.10	79500.00	0.01	0.047	+0.16, -0.16
398.11	-0.00	0.016	+0.10, -0.10	100000.00	0.02	0.047	+0.18, -0.18
501.19	-0.00	0.016	+0.10, -0.10	126000.00	0.02	0.063	+0.20, -0.20

Noise floor data: 1kHz (1/3 Octave) = 0.45 uV, -7.0 dBuV, uncertainty = 0.47 dB
 Flat (20Hz-20kHz) = 3.5 uV, 10.9 dBuV, uncertainty = 0.47 dB
 Awt = 1.7 uV, 4.8 dBuV, uncertainty = 0.46 dB

Uncertainties are given as expanded uncertainty at ~95% confidence interval (k = 2).

Technician: Jason Grace Test Date: 05OCT2005

FIGURE A-30 Certificate of Conformance; PRMLxT1L

Model PRMLxT2B

The Larson Davis PRMLxT2B is a prepolarized microphone preamplifier for use with Larson Davis LxT Sound Level Meters. It requires very little supply current and will drive 200 feet of cable. The preamplifier operates over wide temperature and humidity ranges. It has a built in attenuation of 19 dB for use with 35.5 mV/Pa sensitivity microphones up to 140 dBSPL.

Specifications

Unless otherwise stated, all electroacoustic values are at 23°C, 50% RH, 7.5 Volt supply, 3 m (10') cable and equivalent microphone of 18pF.

Frequency response

with respect to the response at 1 kHz with 8.9 Volts rms input and 18 pF equivalent microphone.

2.5 Hz to 10 Hz +0.1, -0.25 dB

10 Hz to 40 kHz +0.1, -0.1 dB

Lower -3 dB limit < 1 Hz

Attenuation

19 dB (typical)

Input Impedance

10 G Ohm // 2.5 pF

Output Impedance

50 Ohm

Maximum Output

2.8 Vpp

143 dB peak for microphones with 35.5 mV/Pa sensitivity

Maximum Output Current

10 mA peak

Distortion

Harmonics <-58 dBc with 0.7 Volt rms output at 1 kHz

Output Slew Rate

2 V/ μ S (typical)

Electronic Noise

with 18pF equivalent microphone

1.0 μ V typical A-weighted (1.4 μ V max)

1.5 μ V typical Flat 20 Hz to 20 kHz (2.4 μ V max)

Power Supply Voltage

6 to 15 Volts

DC Output Level

\sim 1/2 power supply voltage

Power Supply Current

1.3 mA typical

Temperature Sensitivity

$<\pm$ 0.1 dB from -10 $^{\circ}$ to +50 $^{\circ}$ C (14 $^{\circ}$ to +122 $^{\circ}$ F) operating range to 60 $^{\circ}$ C (140 $^{\circ}$ F)

Humidity Sensitivity

$<\pm$ 0.1 dB from 0 to 90% RH, non-condensing at 40 $^{\circ}$ C (104 $^{\circ}$ F)

Dimensions

12.7 mm diameter x 73 mm length (0.50" dia x 2.88" length)

Microphone Thread

11.7 mm - 60 UNS (0.4606 - 60 UNS)

Cable Driving Capability

LxT SLM (1 V rms output signal)

To 20 kHz with 200'(61 m) cable

Output Connector

Switchcraft® TA5M, 5-Pin male

Pin	Signal
1	Signal Ground
2	Signal Output
3	Power Supply + 7 Volts
4	Preamp sense
5	No Connection
Shell	Connect to preamp housing

Table A-26 Output Connector

Compatibility

Use with PCB® 375B02 or any ½" prepolarized microphone having about 35.5 mV/Pa sensitivity and meeting the mechanical requirements of IEC 61094-4. It can be used with either the Larson Davis ADP043 or ADP008 adapters for ¼" or 1" prepolarized microphones.



**Preamplifier Model: PRMLxT2B Serial Number: 020912
Frequency Response Test Report**

Frequency response of this model PRMLxT2B preamplifier was tested at a level of 139.0 dB μ V with 18 pF microphone capacitance and driving a short cable. Output level at 1000 Hz is 120.001 dB μ V (-18.999 dB relative to input level), uncertainty 0.035 dB. Results are displayed relative to the level at 1000 Hz.

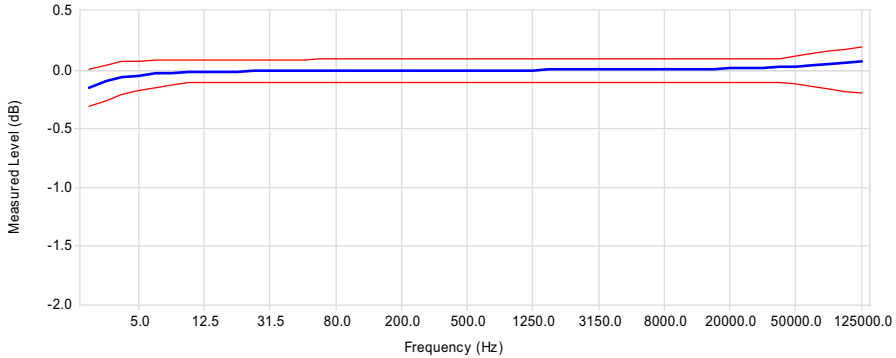

Freq. (Hz)	Meas. (dB)	Uncert. (dB)	Limits (dB)	Freq. (Hz)	Meas. (dB)	Uncert. (dB)	Limits (dB)	Freq. (Hz)	Meas. (dB)	Uncert. (dB)	Limits (dB)
2.51	-0.15	0.08	0.01, -0.31	100.00	-0.01	0.02	0.10, -0.10	3981.07	0.00	0.02	0.10, -0.10
3.16	-0.10	0.06	0.04, -0.26	125.89	-0.01	0.02	0.10, -0.10	5011.87	0.00	0.02	0.10, -0.10
3.98	-0.07	0.06	0.07, -0.21	158.49	-0.00	0.02	0.10, -0.10	6309.57	0.01	0.02	0.10, -0.10
5.01	-0.05	0.04	0.07, -0.17	199.53	-0.00	0.02	0.10, -0.10	7943.28	0.01	0.02	0.10, -0.10
6.31	-0.03	0.04	0.09, -0.14	251.19	-0.00	0.02	0.10, -0.10	10000.00	0.01	0.02	0.10, -0.10
7.94	-0.02	0.04	0.09, -0.13	316.23	-0.00	0.02	0.10, -0.10	12589.25	0.01	0.02	0.10, -0.10
10.00	-0.02	0.02	0.09, -0.11	398.11	-0.00	0.02	0.10, -0.10	15848.93	0.01	0.02	0.10, -0.10
12.59	-0.01	0.02	0.09, -0.11	501.19	-0.00	0.02	0.10, -0.10	19952.62	0.01	0.02	0.10, -0.10
15.85	-0.01	0.02	0.09, -0.11	630.96	-0.00	0.02	0.10, -0.10	25118.87	0.02	0.02	0.10, -0.10
19.95	-0.01	0.02	0.09, -0.11	794.33	-0.00	0.02	0.10, -0.10	31622.78	0.02	0.02	0.10, -0.10
25.12	-0.01	0.02	0.09, -0.11	1000.00	0.00	0.02	0.10, -0.10	39810.72	0.02	0.02	0.10, -0.10
31.62	-0.01	0.02	0.09, -0.11	1258.93	0.00	0.02	0.10, -0.10	50118.72	0.03	0.02	0.12, -0.12
39.81	-0.01	0.02	0.09, -0.11	1584.89	0.00	0.02	0.10, -0.10	63095.73	0.04	0.05	0.14, -0.14
50.12	-0.01	0.02	0.09, -0.11	1995.26	0.00	0.02	0.10, -0.10	79432.82	0.05	0.05	0.16, -0.16
63.10	-0.01	0.02	0.10, -0.10	2511.89	0.00	0.02	0.10, -0.10	100000.00	0.06	0.05	0.18, -0.18
79.43	-0.01	0.02	0.10, -0.10	3162.28	0.00	0.02	0.10, -0.10	125892.54	0.07	0.06	0.20, -0.20

Environmental conditions: 23.8°C, 35.3% RH (0.3°C, 3% RH uncertainty)
 Uncertainties are given as expanded uncertainty at ~95% confidence level (k=2).
 Control File: R:\Provo\Engineering\Tools\Preamps\PRMLxT2B.xml

Technician: James Higley

Test Date: 11 Jul 2011 16:43:47

Test performed at: Larson Davis, a division of PCB Piezotronics, Inc.
 1681 West 820 North, Provo, Utah 84601
 Tel: 716 684-0001 www.LarsonDavis.com

FIGURE A-31 Certificate of Conformance; PRMLxT2B

Model PRMLxT2L

The Larson Davis PRMLxT2L is a prepolarized microphone preamplifier. It requires very little supply current and will drive 100 feet of cable. The preamplifier operates over wide temperature and humidity ranges. It is for use with 20 mV/Pa sensitivity microphones up to 126 dB SPL.

Specifications

Unless otherwise stated, all electroacoustic values are at 23 °C, 50% RH, 7.5 Volt supply, 3 m (10') cable and equivalent microphone of 18pF.

Frequency response

with respect to the response at 1 kHz with 1.1 Volts rms input and 18 pF equivalent microphone.

4 Hz to 10 Hz +0.1, -0.5 dB

10 Hz to 20 kHz +0.1, -0.18 dB

Lower -3 dB limit < 1.5 Hz

Attenuation

1.2 dB (typical)

Input Impedance

10 G Ohm // 3 pF

Output Impedance

50 Ohm

Maximum Output

With LxT SLM

2 V_{pp}

126 dB peak for microphones with 20 mV/Pa sensitivity

Maximum Output Current

10 mA peak

Distortion

Harmonics <-50 dBc with 1.1 Volts rms input at 1 kHz

Output Slew Rate

2 V/μS (typical)

Electronic Noise

with 18pF equivalent microphone

1.8 μV typical A-weighted (2.5 μV max)

3.2 μV typical Flat 20 Hz to 20 kHz (5 μV max)

Power Supply Voltage

6 to 15 Volts

DC Output Level

~1/2 power supply voltage

Power Supply Current

1.3 mA typical

Temperature Sensitivity

$<\pm 0.1$ dB from -10° to $+50^\circ\text{C}$ (14° to $+122^\circ\text{F}$) operating range to 60°C (140°F)

Humidity Sensitivity

$<\pm 0.1$ dB from 0 to 90% RH, non-condensing at 40°C (104°F)

Dimensions

2.7 mm diameter x 125 mm length (0.50" dia x 4.92" length)

Microphone Thread

11.7 mm - 60 UNS (0.4606 - 60 UNS)

Cable Driving Capability

LxT SLM (1 V rms output signal)

To 20 kHz with 200' (60 m) cable

Output Connector

Switchcraft® TA5M, 5-Pin male

Pin	Signal
1	Signal Ground
2	Signal Output
3	Power Supply + 7 Volts
4	Preamp sense
5	No Connection
Shell	Connect to preamp housing

Table A-27 Output Connector

Compatibility

Use with PCB® 375B02 or any ½" prepolarized microphone having about 35.5 mV/Pa sensitivity and meeting the mechanical requirements of IEC 61094-4. It can be used with either the Larson Davis ADP043 or ADP008 adapters for ¼" or 1" prepolarized microphones.

**Preamplifier Model: PRMLxT2L Serial Number: 0104
Certificate of Electrical Conformance**

Frequency response of this model PRMLxT2L preamplifier was tested at a level of 1.157 Vrms with 18pF microphone capacitance and driving a short cable. Output level at 1kHz is 1.0018 Vrms (0.016 dBV), uncertainty 0.035 dB. Output is 3.586 V DC, uncertainty 0.001. Results are displayed relative to the level at 1kHz.

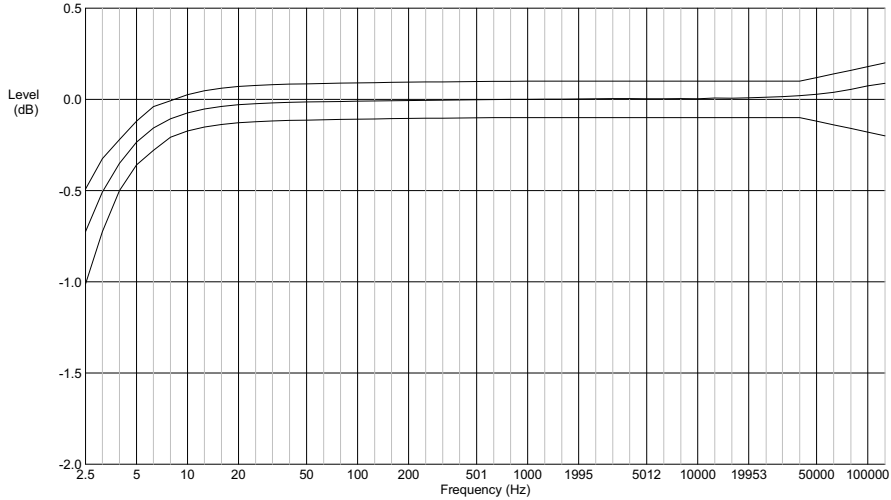

Freq (Hz)	Measured (dB)	Uncert (dB)	Tolerance (dB)	Freq (Hz)	Measured (dB)	Uncert (dB)	Tolerance (dB)
2.51	-0.73	0.075	-0.49, -1.01	630.96	-0.00	0.016	+0.10, -0.10
3.16	-0.51	0.058	-0.32, -0.73	794.33	0.00	0.016	+0.10, -0.10
3.98	-0.35	0.058	-0.22, -0.50	1000.00	0.00	0.016	+0.10, -0.10
5.01	-0.23	0.036	-0.12, -0.36	1258.90	0.00	0.016	+0.10, -0.10
6.31	-0.16	0.036	-0.04, -0.28	1584.90	0.00	0.016	+0.10, -0.10
7.94	-0.11	0.036	-0.01, -0.21	1995.30	0.00	0.016	+0.10, -0.10
10.00	-0.07	0.016	+0.03, -0.17	2511.90	0.00	0.016	+0.10, -0.10
12.59	-0.05	0.016	+0.05, -0.15	3162.30	0.00	0.016	+0.10, -0.10
15.85	-0.04	0.016	+0.06, -0.14	3981.10	0.01	0.016	+0.10, -0.10
19.95	-0.03	0.016	+0.07, -0.13	5011.90	0.00	0.016	+0.10, -0.10
25.12	-0.02	0.016	+0.08, -0.12	6309.60	0.00	0.016	+0.10, -0.10
31.62	-0.02	0.016	+0.08, -0.12	7943.30	0.00	0.016	+0.10, -0.10
39.81	-0.02	0.016	+0.08, -0.12	10000.00	0.00	0.016	+0.10, -0.10
50.12	-0.01	0.016	+0.09, -0.11	12589.00	0.01	0.016	+0.10, -0.10
63.10	-0.01	0.016	+0.09, -0.11	15849.00	0.01	0.016	+0.10, -0.10
79.43	-0.01	0.016	+0.09, -0.11	19953.00	0.01	0.016	+0.10, -0.10
100.00	-0.01	0.016	+0.09, -0.11	25250.00	0.01	0.022	+0.10, -0.10
125.89	-0.01	0.016	+0.09, -0.11	31500.00	0.02	0.022	+0.10, -0.10
158.49	-0.01	0.016	+0.09, -0.11	39750.00	0.02	0.022	+0.10, -0.10
199.53	-0.01	0.016	+0.09, -0.10	50000.00	0.03	0.022	+0.12, -0.12
251.19	-0.01	0.016	+0.10, -0.10	63000.00	0.04	0.047	+0.14, -0.14
316.23	-0.00	0.016	+0.10, -0.10	79500.00	0.06	0.047	+0.16, -0.16
398.11	-0.00	0.016	+0.10, -0.10	100000.00	0.07	0.047	+0.18, -0.18
501.19	-0.00	0.016	+0.10, -0.10	126000.00	0.09	0.063	+0.20, -0.20

Noise floor data: 1kHz (1/3 Octave) = 0.37 uV, -8.6 dBuV, uncertainty = 0.47 dB
 Flat (20Hz-20kHz) = 3.7 uV, 11.3 dBuV, uncertainty = 0.47 dB
 Awt = 2.3 uV, 7.4 dBuV, uncertainty = 0.46 dB

Uncertainties are given as expanded uncertainty at ~95% confidence interval (k = 2).

Technician: Jason Grace Test Date: 09MAR2005

FIGURE A-32 Certificate of Conformance; PRMLxT2L

Vibration Sensitivity

In these tests, the LxT is mounted on an electrodynamic exciter and vibrated sinusoidally at an amplitude of 1.0 m/s^2 at the following frequencies: 35.5, 63, 125, 250, 500, 630, 800 and 1,000 Hz. The tests are performed with the meter oriented such that vibrations are produced in two different directions: parallel to the microphone diaphragm and perpendicular to the diaphragm.

The resulting sound levels are measured using two different microphones:

The microphone connected to the instrument, which is moving

A reference microphone at a fixed position

The following two sections show diagrams of the test setup and the data measured.

Vibration Parallel to the Microphone Diaphragm

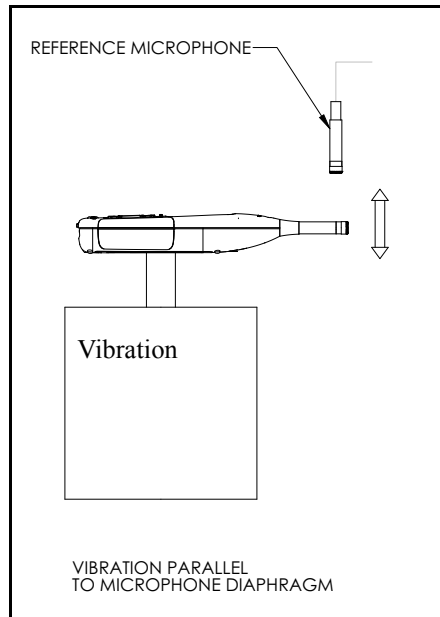

FIGURE A-33 Vibration Parallel to Microphone Diaphragm

Frequency	L_{aeq}	Ref
31.5	35.7	35.4
63	35.5	34.8
125	35.8	36.8
250	47.7	47.9

Table A-28 Axis of Vibration Parallel to the Microphone Diaphragm

Frequency	L_{aeq}	Ref
500	52.6	51.4
630	60.5	50.4
800	61.0	54.4
1,000	62.2	60.0

**Table A-28 Axis of Vibration Parallel to the Microphone Diaphragm
Vibration Perpendicular to the Microphone Diaphragm**

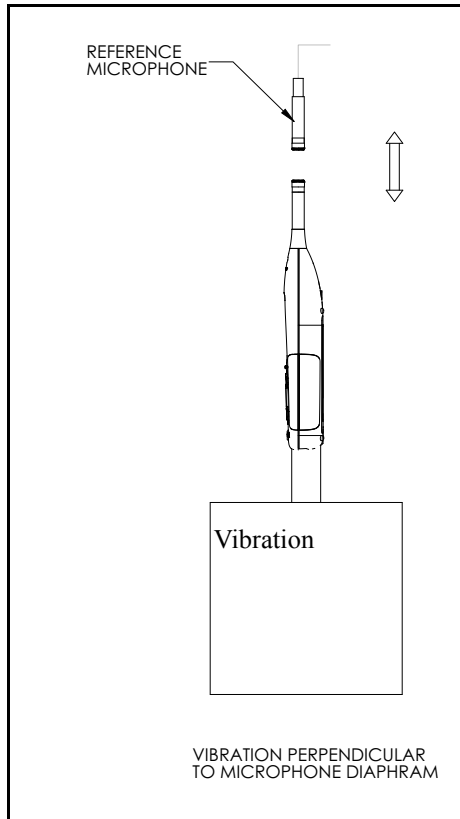

FIGURE A-34 Vibration Perpendicular to Microphone Diaphragm

Frequency	L_{aeq}	Ref
31.5	35.9	35.6
63	38.6	34.5
125	46.0	35.5
250	54.1	39.4
500	67.1	44.2
630	82.6	70.0
800	69.7	45.7
1,000	69.2	51.7

Table A-29 Axis of Vibration Perpendicular to the Microphone Diaphragm

B**Testing to IEC61672-1**

This appendix presents information for measuring the sound level meter functionality of the LxT according to IEC61672-1.

Sections 5, 6, 7 and 9 (except 9.3)

The following table references sections and tables in this manual where information called for in specific sections of IEC61672-1 can be found. In certain instances the requested information is not applicable, as noted in the Comments column.

Further information called for in section 9.3 for testing, as appropriate for a sound level meter, can be found in "Section 9.3" on page B-10.

Section	LxT Manual Section	Comments
5.1.4	LxT Components	
5.1.6	Optional Accessories Making a Measurement	
5.1.7	Connecting the Microphone and Preamplifier Connecting the Preamplifier to the LxT	
5.1.8		Computer software is not an integral part of the LxT
5.1.10	Frequency Weightings	
5.1.12		The Model LxT measures sound level using a single range
5.1.13	Section 9.3 for LxT1 and LxT2	
5.1.14	Hardkeys Leq	

Section	LxT Manual Section	Comments
5.1.15	Typical Z-Weight Frequency Response Electrical Insert Signals	
5.1.16	Highest Sound Pressure Level for LxT1 and LxT2	
5.1.17		The Model LxT is a single channel instrument
5.1.18	Performing Measurements	
5.2.1	Calibrator	
5.2.3	Calibrating the LxT1 and 377B02 micro- phone Calibrating the LxT2 and the 375B02 micro- phone	
5.2.4	Frequency Response and Corrections	
5.2.5	Frequency Response and Corrections	
5.2.7	Periodic Testing	
5.2.8	Periodic Testing	
5.4.12		No optional frequency responses
5.5.9	Linear Measurement Starting Level	
5.5.10	Linear Measurement Starting Level	
5.5.11	Display Device	
5.6.1	Inherent Noise	
5.6.2	Inherent Noise	
5.6.3	LxT Performance Specifications	
5.6.4	LxT Performance Specifications	
5.6.5	Data Storage After Improper Shutdown	
5.7.1	LxT Specifications	
5.10.1	Overload Indication	
5.11.1		See comment for section 5.11.2

Section	LxT Manual Section	Comments
5.11.2		LxT measures sound level using a single range. The lower limit for level linearity error is caused by the inherent noise from the microphone and electronic elements within the sound level meter.
5.12.1	LxT Performance Specifications	
5.14	Threshold and Criterion	
5.15.2	Data Display	
5.15.3	Data Display	
5.15.4	Data Display	
5.15.5	General Specifications	
5.15.6	Integration Method on SLM Tab	
5.15.7	Software	
5.15.8		The LxT uses no alternative display devices
5.16.1	"Typical Z-Weight Frequency Response Jack Function	
5.17.1	Control Tab Time	
5.17.1 NOTE 2	General Specifications	
5.17.2	Manual, Timed Stop, or Stop When Stable Modes	
5.18.1	Cables	
5.18.2	Radio Frequency Emission	
5.19.2		The LxT is a single channel instrument
5.20.2	Battery Power Voltage Range	
5.20.3	Power Supply	
5.20.4	Powering the SoundTrack LxT [®]	

Section	LxT Manual Section	Comments
5.20.5		The LxT is not intended to be powered by a public source of AC power
6.1.2	Typical Stabilization Time	
6.2.2	Calibrating the LxT1 and 377B02 microphone Calibrating the LxT2 and the 375B02 microphone	
6.5.2	General Specifications	
6.6.1	AC Power and Radio Frequency Susceptibility	
6.6.3		No detectable increase in any direction with application of 74 dB A-weighted sound level.
6.6.9	AC Power and Radio Frequency Susceptibility	
7.1	Microphone Extension Cable	
7.2	Effect of Windscreen	
7.4	Octave Band Analyzer Tab (Optional)	

9.2.1 General

a	Standards Met by LxT	
b	Preparation Microphone Extension Cable Use of a Windscreen	
c	Standard Accessories Optional Accessories	
d		No microphone extension or microphone extension cable is required to meet specified
e		The LxT is a single channel instrument

9.2.2 Design Features

Section	LxT Manual Section	Comments
a	Parameters Measured	
b	Frequency Response	
c	Sound Level Meter Specifications	
d	Sound Level Meter Specifications	
e	LxT Performance Specifications	
f		The LxT measures sound level using a single range
g	LxT Specifications LxT Performance Specifications	
h	LxT Performance Specifications	
i	Sound Level Meter Specifications	
j		Computer software is not an integral part of the LxT
k		None. No optional frequency weightings
9.2.3 Power Supply		
a	"Power Supply Battery Operating Lifetime	
b	Power Indicator	
c	Power Supply	
d		The LxT is not intended to be powered by a public source of AC power
9.2.4 Adjustments to Indicated Levels		
a	Recommended Calibrator	
b	Recommended Calibrator	
c	Calibration	
d	Frequency Response and Corrections	
9.2.5 Operating the Sound Level Meter		

Section	LxT Manual Section	Comments
a	General Specifications	
b	Positioning the LxT	
c		The LxT measures sound level using a single range
d	Data Storage After Improper Shutdown	
e	Performing Measurements	
f	Integration Method on SLM Tab	
g	Control Tab Time	
h	Manual, Timed Stop, or Stop When Stable Modes	
i	Hardkeys Leq	
j	Overload Indication Leq	
k	Measurement Range	
l	Triggers Tab	
m	Software	
n	LxT Components	
o	Inherent Noise	
p	Typical Z-Weight Frequency Response Jack Function	

9.2.6 Accessories

a	Effect of Windscreen	
b	Microphone Extension Cable	
c	Octave Band Analyzer Tab (Optional)	
d		No manufacturer-provided auxiliary devices are provided

9.2.7 Influence of variations in environmental conditions
--

Section	LxT Manual Section	Comments
a		No components of the LxT are intended to be operated only in an environmentally controlled enclosure
b	LxT Specifications	
c	Microphone Reference Point	

The following two sections are related to the LxT1 and the LxT2 configurations, respectively. In each, information is provided which corresponds to the specific item number in this standard.

LxT1

Section 9.2.4

a) Calibrator

The calibrator to be used with the LxT1 is the Larson Davis Model CAL200.

b) Calibration Frequency

The calibration check frequency is 1000 Hz.

c) Calibration Procedure

For calibration refer to the chapter "Calibration" on page 7-1.

d) Frequency Response and Corrections

Larson Davis LxT1 with PRMLxT1 and typical 377A02 Microphone
average frequency responses and corrections
Required by IEC 61672-1 Sections 5.2.4, 5.2.5, 5.2.6 and 9.2.4 (d)

Frequency	0° Free Field Response	0° Free Field Corrections ¹	Effect of Wind Screen	Wind Screen on LxT1	0° Free Field Corrections with Wind Screen on LxT1 ¹	expansion uncertainty of Correction @
Hz	dB	dB	dB	dB	dB	dB
63.10	0.0	0.0	0.0	0.0	0.0	0.0
79.43	0.0	0.0	0.0	0.0	0.0	0.0
100.00	0.0	0.0	0.0	0.0	0.0	0.0
125.89	0.0	0.0	0.0	0.0	0.0	0.0
158.49	0.0	0.0	0.0	0.0	0.0	0.0
199.53	0.0	0.0	0.0	0.0	0.0	0.0
251.19	0.0	0.0	0.0	0.0	0.0	0.0
316.23	-0.1	0.1	0.1	0.0	0.0	0.0
398.11	0.2	-0.2	0.0	0.0	0.0	0.0
501.19	0.2	-0.2	0.1	0.1	-0.1	-0.1
630.96	0.2	-0.2	0.0	0.1	-0.1	-0.1
794.33	0.2	-0.2	0.1	0.1	-0.1	-0.1
1000.00	0.0	0.0	0.1	0.0	0.0	0.0
1059.25	0.0	0.0	0.1	0.0	0.0	0.0
1122.02	-0.2	0.1	0.2	-0.1	0.1	0.1
1188.50	-0.2	0.2	0.2	-0.1	0.1	0.1
1258.93	-0.4	0.4	0.2	-0.1	0.1	0.1
1333.52	-0.3	0.3	0.2	0.0	0.0	0.0
1412.54	-0.2	0.2	0.3	-0.1	0.1	0.1
1496.24	-0.1	0.1	0.3	0.0	0.0	0.0
1584.89	0.0	0.0	0.3	0.2	-0.2	-0.2
1678.80	0.0	0.0	0.4	0.2	-0.2	-0.2
1778.28	0.0	0.0	0.4	0.3	-0.3	-0.3
1883.65	-0.1	0.1	0.4	0.4	-0.4	-0.4
1995.26	0.2	-0.2	0.4	0.7	-0.7	-0.7
2113.49	0.4	-0.4	0.5	0.9	-0.9	-0.9
2238.72	0.3	-0.3	0.5	0.8	-0.8	-0.8
2371.37	0.0	0.0	0.5	0.7	-0.7	-0.7
2511.89	0.0	0.0	0.5	0.7	-0.7	-0.7
2660.73	0.2	-0.2	0.6	0.7	-0.7	-0.7
2818.38	0.0	0.0	0.5	0.6	-0.6	-0.6
2985.38	-0.2	0.2	0.5	0.3	-0.3	-0.3
3162.28	0.0	0.1	0.4	0.2	-0.2	-0.2
3349.65	0.0	0.0	0.3	0.3	-0.3	-0.3
3548.13	-0.1	0.1	0.3	-0.1	0.1	0.1

Continued on next page.

3548.13	-0.1	0.1	0.3	-0.1	0.1	0.1
3758.37	0.1	-0.1	0.2	0.3	-0.3	0.1
3981.07	0.1	-0.1	0.1	0.1	-0.1	0.1
4216.97	0.0	0.0	0.0	-0.1	0.1	0.1
4466.84	0.4	-0.4	-0.1	0.2	-0.2	0.1
4731.51	0.1	-0.1	-0.3	-0.4	0.4	0.1
5011.87	-0.1	0.1	-0.1	-0.5	0.5	0.1
5308.84	0.0	0.0	-0.1	0.1	-0.1	0.1
5623.41	0.0	0.0	-0.1	-0.1	0.1	0.1
5956.62	0.1	-0.1	0.0	-0.3	0.3	0.1
6309.57	0.2	0.2	0.1	0.4	-0.4	0.1
6683.44	0.1	-0.1	0.1	0.1	-0.1	0.1
7079.46	0.1	-0.1	0.0	-0.1	0.1	0.1
7498.94	0.0	0.0	-0.1	-0.4	0.4	0.1
7943.28	0.0	0.0	-0.3	-0.7	0.7	0.1
8413.95	0.3	-0.3	-0.4	-0.5	0.5	0.1
8912.51	0.1	-0.1	-0.5	-0.4	0.4	0.1
9440.61	0.0	0.0	-0.3	-0.6	0.6	0.1
10000.00	0.0	0.0	-0.2	-0.4	0.4	0.1
10592.54	0.1	-0.1	-0.1	-0.4	0.4	0.1
11220.18	0.1	-0.1	-0.4	-0.6	0.6	0.1
11885.02	0.0	0.0	-0.7	-1.0	1.0	0.1
12589.25	0.3	-0.3	-0.7	-0.6	0.6	0.1
13335.21	0.3	-0.3	-0.8	-0.4	0.4	0.1
14125.38	0.1	-0.1	-0.5	-0.4	0.4	0.1
14962.36	0.1	-0.1	-0.8	-0.5	0.5	0.1
15848.93	-0.2	0.2	-0.1	-0.5	0.5	0.2
16788.04	-0.2	0.2	-1.0	-0.9	0.9	0.2
17782.79	-0.1	0.1	-1.0	-1.2	1.2	0.1
18836.49	-0.2	0.2	-0.9	-1.9	1.9	0.1
19952.62	-0.1	0.1	-1.3	-3.1	3.1	0.1

¹add numbers in this column to levels read on the LxT1 to correct the level at a specific frequency

Section 9.3

a) Reference Sound Pressure Level

The reference sound pressure level is 114 dB re 20 μ Pa.

b) Reference Level Range

The reference level range is normal.

c) Microphone Reference Point

The microphone reference point is the center of the diaphragm of the 377B02 microphone.

d) Periodic Testing

Table 2 lists values of Larson Davis LxT1 with PRMLxT1 and 377B02 Microphone adjustment data of A-weighted levels used for periodic measurements.

Table 2 - Larson Davis LxT1 with PRMLxT1 and 377B02 Microphone						
adjustment data of A-weighted levels used for periodic testing						
Frequency	0° Free Field		0° Free Field		expanded uncertainty of Corrections @ 95% confidence	
	0° Free Field Corrections from B&K 4226 Calibrator ¹	Corrections with WS from B&K 4226 Calibrator ¹	0° Free Field Corrections from B&K UA0033 EA ¹	Corrections with WS from B&K UA0033 EA ¹		
Hz	dB	dB	dB	dB	dB	
31.62	-0.2	-0.2	0.0	-0.1	0.25	
63.10	-0.1	-0.2	0.0	-0.1	0.25	
125.89	0.0	-0.1	0.0	-0.1	0.25	
251.19	-0.1	-0.1	0.0	-0.1	0.25	
501.19	0.0	0.0	0.1	0.1	0.25	
1000.00	0.0	0.0	0.0	0.0	0.25	
1995.26	0.6	0.9	0.6	0.9	0.30	
3981.07	1.1	1.1	1.0	1.0	0.35	
7943.28	2.3	1.9	2.9	2.6	0.40	
12589.25	5.2	4.4	6.8	6.0	0.50	
15848.93	5.4	4.3	8.1	7.0	0.60	

¹add numbers in this column to levels read on the LxT to correct to the 0° Free Field level at a specific frequency

EA - Electrostatic Actuator
WS - Wind Screen

e) Linear Operating Range

A-weighted sound levels for the LxT1L at the upper and lower limits of the linear operating ranges.

31.5 Hz	1 kHz	4 kHz	8 kHz	12.5 kHz
17.5 dB to 79.4 dB	20 dB to 118.8 dB	21 dB to 119.8 dB	21 dB to 117.7 dB	20 dB to 114.5 dB

f) Linear Measurement Starting Level

The starting point for measuring level linear errors on the reference range is 114 dB.

g) Electrical Insert Signals

The electrical design of the input device to insert electrical signals into the preamplifier for the 377B02 microphone is a series $12\text{pF} \pm 5\%$ capacitor. The Larson Davis ADP076 is used for this purpose. The ADP076 can be used for noise floor measurements by attaching the included short on the front of the ADP076.

h) Inherent Noise

Inherent Noise of the LxT1 (low range) with PRMLxT1L:

Weighting	Total Noise ¹	Electrical Noise ²
A	19	12
C	21.2	17
Flt	27.5	25

¹ combination of the electronic noise and the thermal noise of the microphone at 20°C measured in a sealed cavity and vibration isolated

² electronic noise of the instrument with an ADP090 in place of the microphone

i) Highest Sound Pressure Level

The highest sound pressure level the Larson Davis LxT1 is designed to accommodate at the level of overload is 140 dB. The peak-to-peak voltage at this level is 28 V_{pp} input through the ADP005.

j) Battery Power Voltage Range

The battery power supply voltage range for which the LxT1 conform to this standard:

6.4 Volts maximum

The LxT will shut down if the battery is below 4.0 Volts when used with alkaline batteries. Therefore from 4.0 to 6.4 Volts is the usable range of battery voltage.

k) Display Device

The display device will display all levels over the entire linear operating range.

l) Typical Stabilization Time

The typical time interval needed to stabilize after changes in environmental conditions:

For a temperature change of 5°C then 30 minutes are required.

For a static pressure change of 5 kPa then 15 seconds are required.

For a humidity change of 30% (non-condensing) then 30 minutes are required.

m) Field Strength > 10 V/m

The Larson Davis model LxT1 was not measured for field strengths greater than 10 V/m.

n) Radio Frequency Emission

The mode of operation of the LxT1 that produces the greatest radio frequency emission levels was with the LxT1 set to run and with an LxT-EXC010 (10' microphone extension cable) used to connect the PRMLxT1 to the LxT1. Adding the USB cable did not emit more radio frequencies levels.

o) AC Power and Radio Frequency Susceptibility

The mode of operation of the LxT1 that produced the greatest measurement susceptibility to A.C. power frequency and radio frequency fields was with the LxT1 set to run, USB cable attached and with an LxT-EXC010 (10' microphone extension cable) between the PRMLxT1 and the LxT1.

LxT2

Section 9.2.4

a) Calibrator

The calibrator to be used with the LxT2 is the Larson Davis Model CAL150.

b) Calibrator Frequency

The calibration check frequency is 1000 Hz.

c) Calibration Procedure

For calibration refer to the chapter "Calibration" on page 7-1.

d) Frequency Response

Larson Davis LxT2 with PRMLxT2B Preamp and typical 375B02 Microphone
 average frequency responses and corrections
 Required by IEC 61672-1 Sections 5.2.4, 5.2.5, 5.2.6 and 9.2.4 (d)

Frequency	0° Free Field Response ²	0° Free Field Corrections ^{1,2}	Effect of Wind Screen	Wind Screen on LxT2 0° Free Field	0° Free Field Corrections with Wind Screen on LxT2 ¹	expanded uncertainty of Corrections @ 95%
Hz	dB	dB	dB	dB	dB	dB
63.10	0.0	0.0	0.0	0.0	0.0	0.4
79.43	0.0	0.0	0.0	0.0	0.0	0.4
100.00	0.0	0.0	0.0	0.0	0.0	0.4
125.89	0.0	0.0	0.0	0.0	0.0	0.4
158.49	0.0	0.0	0.0	0.0	0.0	0.4
199.53	0.0	0.0	0.0	0.0	0.0	0.4
251.19	0.0	0.0	0.0	0.0	0.0	0.4
316.23	0.1	-0.1	0.0	0.1	-0.1	0.4
398.11	0.0	0.0	0.1	0.1	-0.1	0.4
501.19	0.1	-0.1	0.1	0.1	-0.1	0.4
630.96	0.0	0.0	0.1	0.1	-0.1	0.4
794.33	-0.1	0.1	0.2	0.1	-0.1	0.4
1000.00	-0.1	0.1	0.2	0.1	-0.1	0.4
1059.25	-0.1	0.1	0.2	0.1	-0.1	0.4
1122.02	-0.4	0.4	0.3	-0.1	0.1	0.4
1188.50	-0.4	0.4	0.3	-0.1	0.1	0.4
1258.93	-0.4	0.4	0.3	-0.1	0.1	0.4
1333.52	-0.5	0.5	0.3	-0.2	0.2	0.4
1412.54	-0.4	0.4	0.3	-0.1	0.1	0.5
1496.24	-0.4	0.4	0.3	-0.2	0.2	0.5
1584.89	-0.2	0.2	0.3	0.1	-0.1	0.6
1678.80	-0.3	0.3	0.4	0.1	-0.1	0.6
1778.28	-0.1	0.1	0.4	0.2	-0.2	0.6
1883.65	-0.2	0.2	0.4	0.2	-0.2	0.6
1995.26	0.0	0.0	0.4	0.4	-0.4	0.6
2113.49	0.1	-0.1	0.6	0.6	-0.6	0.6
2238.72	0.2	-0.2	0.6	0.8	-0.8	0.6
2371.37	0.0	0.0	0.6	0.6	-0.6	0.6
2511.89	-0.1	0.1	0.6	0.5	-0.5	0.6
2660.73	-0.1	0.1	0.6	0.5	-0.5	0.6
2818.38	-0.2	0.2	0.6	0.4	-0.4	0.6
2985.38	-0.5	0.5	0.6	0.1	-0.1	0.6
3162.28	-0.4	0.4	0.4	0.0	0.0	0.6
3349.65	-0.5	0.5	0.4	-0.1	0.1	0.6
3548.13	-0.6	0.6	0.3	-0.3	0.3	0.6
3758.37	-0.5	0.5	0.3	-0.2	0.2	0.6
3981.07	-0.4	0.4	0.2	-0.2	0.2	0.6
4216.97	-0.6	0.6	0.2	-0.4	0.4	0.6
4466.84	-0.3	0.3	0.1	-0.2	0.2	0.6
4731.51	-0.5	0.5	-0.1	-0.6	0.6	0.6
5011.87	-0.7	0.7	-0.1	-0.8	0.8	0.6
5308.84	-0.5	0.5	0.0	-0.5	0.5	0.6
5623.41	-0.6	0.6	0.1	-0.5	0.5	0.6
5956.62	-1.1	1.1	0.4	-0.7	0.7	0.6
6309.57	-0.6	0.6	0.4	-0.2	0.2	0.6
6683.44	-0.5	0.5	0.2	-0.3	0.3	0.6
7079.46	-0.8	0.8	0.2	-0.7	0.7	0.6
7498.94	-0.8	0.8	0.0	-0.8	0.8	0.6
7943.28	-1.0	1.0	0.0	-1.1	1.1	0.6
8413.95	-1.0	1.0	0.0	-1.0	1.0	0.6
8912.51	-0.8	0.8	-0.1	-1.0	1.0	0.6
9440.61	-0.8	0.8	-0.3	-1.1	1.1	0.6
10000.00	-1.0	1.0	-0.1	-1.1	1.1	0.6
10592.54	-1.2	1.2	0.1	-1.1	1.1	0.7
11220.18	-0.8	0.8	-0.1	-0.9	0.9	0.8

Continued on next page

11220.18	-0.8	0.8	-0.1	-0.9	0.9	0.8
11885.02	-0.8	0.8	-0.3	-1.1	1.1	0.9
12589.25	-0.8	0.8	-0.2	-1.0	1.0	1.0
13335.21	-0.9	0.9	-0.3	-1.2	1.2	1.0
14125.38	-1.1	1.1	-0.3	-1.4	1.4	1.0
14962.36	-0.7	0.7	-0.3	-1.0	1.0	1.0
15848.93	-0.7	0.7	-0.4	-1.1	1.1	1.0
16788.04	-0.7	0.7	-0.8	-1.5	1.5	1.0
17782.79	-0.7	0.7	-0.7	-1.5	1.5	1.0
18836.49	-0.7	0.7	-0.8	-1.5	1.5	1.0
19952.62	-0.7	0.7	-0.9	-1.6	1.6	1.0

¹add numbers in this column to levels read on the LxT2 to correct the level at a specific frequency
²data includes average free-field microphone response and average effects of reflections and diffraction

SLM with PRM831 and 377B02 Microphone

Frequency	0° Free Field Corrections from B&K 4226 Calibrator ^a	0° Free Field Corrections with WS from B&K 4226 Calibrator ^a	0° Free Field Corrections from B&K UA0033 EA ^a	0° Free Field Corrections with WS from B&K UA0033 EA ^a	expanded uncertainty of Corrections @ 95% confidence ^a
Hz	dB re 1 kHz	dB re 1 kHz	dB re 1 kHz	dB re 1 kHz	dB
31.62	-0.14	-0.14	-0.09	-0.09	0.25
63.10	-0.11	-0.11	-0.09	-0.09	0.25
125.89	-0.21	-0.21	-0.20	-0.20	0.25
251.19	-0.08	-0.08	-0.09	-0.09	0.25
501.19	-0.22	-0.12	-0.22	-0.12	0.25
1000.00	0.00	0.00	0.00	0.00	0.25
1995.26	-0.05	-0.45	-0.02	-0.42	0.25
3981.07	0.76	0.76	0.78	0.78	0.25
7943.28	2.91	3.21	3.30	3.60	0.35
12589.25	5.85	6.15	6.42	6.72	0.50
15848.93	7.74	7.34	8.46	8.06	0.50

a. Add numbers in this column to levels read on the SLM to correct to the 0° Free Field level at frequency

EA - Electrostatic Actuator

WS - Windscreen

Note: Data was taken at reference conditions 23° C, 50% RH, 101.3 kPa

Section 9.3

a) Reference Sound Pressure Level

The reference sound pressure level is 114 dB re 20 μ Pa.

b) Reference Level Range

The reference level range is normal.

c) Microphone Reference Point

The microphone reference point is the center of the diaphragm of the 7052 microphone.

d) Periodic Testing

See table 2 for values of Larson Davis LxT2 with PRMLxT2 and 7052 Microphone adjustment data of A-weighted levels used for periodic measurements.

e) Linear Operating Range

A-weighted sound levels for the LxT2 at the upper and lower limits of the linear operating ranges.

31.5 Hz	1 kHz	4 kHz	8 kHz	12.5 kHz
77 dB to 99.6 dB	34 dB to 139 dB	33 dB to 138 dB	36 dB to 137.9 dB	38 dB to 134.7 dB

f) Linear Measurements Starting Level

The starting point for measuring the level linear errors on the reference range is 114 dB.

g) Electrical Insert Signals

The electrical design of the input device to insert electrical signals into the preamplifier for the 375A02 microphone is a series 18pF \pm 5% capacitor. The Larson Davis ADP005 is used for this purpose. The ADP005 can be used for noise floor measurements by attaching the included short on the front of the ADP005.

h) Inherent Noise

Inherent Noise of the LxT2:

Weighting	Total Noise ¹	Electrical Noise ²
A	27	26
C	27	25
Flt	32	30

¹ combination of the electronic noise and the thermal noise of the microphone at 20°C measured in a sealed cavity and vibration isolated

² electronic noise of the instrument with an ADP005 in place

i) Highest Sound Pressure Level

The highest sound pressure level the Larson Davis LxT2 is designed to accommodate at the level of overload is 139 dB. The peak-to-peak voltage at this level is 10.7 V_{pp} input through the ADP005.

Microphone/ Preamplifier	Damage Level		Overload Level	
	Sound Pressure Level, dB	Electrical Input Facility, V _{peak}	Sound Pres- sure Level, dB	Electrical Input Facility, V _{peak}
375B02/ PRMLxTB	159	60	139	6

j) Battery Power Voltage Range

The battery power supply voltage range for which the LxT2 conform to this standard:

6.4 Volts maximum

The LxT will shut down if the battery is below 4.0 Volts when used with alkaline batteries. Therefore from 4.0 to 6.4 Volts is the usable range of battery voltages.

k) Display Device

The display device will display all levels over the entire linear operating range.

l) Typical Stabilization Time

The typical time interval needed to stabilize after changes in environmental conditions.

For a temperature change of 5°C then 30 minutes are required.

For a static pressure change of 5 kPa then 15 seconds are required.

For a humidity change of 30% (non-condensing) then 30 minutes are required.

m) Field Strength > 10 V/m

The Larson Davis model LxT2 was not measured for field strengths greater than 10 V/m.

n) Radio Frequency Emission

The mode of operation of the LxT2 that produced the greatest measurement radio frequency emission levels was with the LxT2 set to run and with an LxT-EXC010 (10' microphone extension cable) used to connect the PRMLxT2 to the LxT2. Adding the USB cable did not emit more radio frequencies levels.

o) AC Power and Radio Frequency Susceptibility

The mode of operation of the LxT2 that produced the greatest measurement susceptibility to A.C. power frequency and radio frequency fields was with the LxT2 set to run, USB cable attached and with an LxT-EXC010 (10' microphone extension cable) between the PRMLxT2 and the LxT2.

C

Glossary and Formulas

This appendix contains technical definitions of key acoustical and vibration terms and formulas commonly used with Larson Davis instruments. Refer to American National Standards Institute document S1.1-1994 for additional definitions. Specific use of the terms defined are in the main body of the text.

Allowed Exposure Time (T_i)

The allowed time of exposure to sound of a constant level given a Criterion Level, Criterion Duration, and Exchange Rate.

$$T_i = \frac{T_c}{2^{(L_{avg} - L_c)/Q}} = \frac{T_c}{10^{(L_{avg} - L_c)/q}}$$

where L_c is the Criterion Sound Level, T_c is the Criterion Duration, Q is the Exchange Rate, K is the Exchange Rate Factor and L_{avg} is the Average Sound Level.

Example: If $L_c = 90$, $T_c = 8$, $Q = 3$ and $L_{avg} = 95$ then

$$T_i = \frac{8}{10^{(95-90)/10}} = \frac{8}{2^{(95-90)/3}} = 5.656 = 5 \text{ hours and } 39 \text{ minutes}$$

This means that if a person is exposed for 5 hours and 39 minutes he will have accumulated a Noise Dose of 100%.

Standard: ANSI S12.19

Average Sound Level (L_{avg})

The logarithmic average of the sound during a Measurement Duration (specific time period), using the chosen Exchange Rate Factor. Exposure to sounds at this level over the measurement duration result in the same noise dose as the actual (unsteady) sound. If the Measurement Duration is the same as the Criterion Duration, then $L_{avg}=L_{TWA(LC)}$

$$L_{avg} = q \text{Log}_{10} \left(\frac{1}{T} \int_{T_1}^{T_2} 10^{(L_p(t))/q} dt \right)$$

where the Measurement Duration (specified time period) is $T=T_2-T_1$ and q is the Exchange Rate Factor. Only sound levels above the Threshold Level are included in the integral. *Standard: ANSI S12.19*

CNEL

In the state of California, Community Noise Equivalent Level (CNEL), a commonly used community noise descriptor, is defined by the following formula:

$$CNEL = 10 \log_{10} \left\{ \frac{1}{24} \left[\sum_{0000}^{0700} 10^{(L_i+10)/10} + \sum_{0700}^{1900} 10^{L_i/10} + \sum_{1900}^{2200} 10^{(L_i+5)/10} + \sum_{2200}^{2400} 10^{(L_i+10)/10} \right] \right\}$$

This is essentially the same as the L_{DEN} using default values, with the exception that the evening period begins at 22.00 instead of 23.00. Thus, by making this change in the L_{DEN} settings, the measured value will represent CNEL.

Criterion Duration (T_c)

The time required for a constant sound level equal to the Criterion Level to produce a Noise Dose of 100%. Criterion Duration is typically 8 hours.

Example: If the Criterion Level = 90 dB and the Criterion Duration is 8 hours, then a sound level of 90 dB for 8 hours, will produce a 100% Noise Dose. See Noise Dose.

Standard: ANSI S12.19

Criterion Sound Exposure (CSE)

The product of the Criterion Duration and the mean square sound pressure associated with the Criterion Sound Level when adjusted for the Exchange Rate. It is expressed in Pascal-squared seconds when the exchange rate is 3 dB.

where q is the Exchange Rate Factor. See Exchange Rate.

$$CSE = T_c 10^{L_c/q}$$

L_c is the Criterion Sound Level.

Standard: ANSI S1.25

Criterion Sound Level (L_c)

The sound level which if continually applied for the Criterion Duration will produce a Noise Dose of 100%. The current OSHA Criterion Sound Level is 90 dB.

Standard: ANSI S12.19

Daily Personal Noise Exposure ($L_{EP,d}$)

It is the level of a constant sound for which exposure over the Criterion Duration contains the same sound energy as the actual, unsteady sound over a specific period.

Example: If the Criterion Duration = 8 hours and the specific period is 4 hours and the average level during the 4 hours is 86 dB, then the $L_{EP,d} = 83$ dB.

Day, Evening, Night Level (L_{den})

A rating of community noise that differentiates between daytime, evening and nighttime noise exposure. The equation for day-night level L_{DEN} is:

$$L_{den} = 10 \log_{10} \left\{ \frac{1}{24} \left[\sum_{0000}^{0700} 10^{(L_i + 10)/10} + \sum_{0700}^{1900} 10^{L_i/10} + \sum_{1900}^{2200} 10^{(L_i + 5)/10} + \sum_{2200}^{2400} 10^{(L_i + 10)/10} \right] \right\}$$

The continuous equivalent sound level is generally calculated on an hourly basis and is shown in the equation as L. The levels for the hourly periods from midnight to 7 a.m. have 10 added to them to represent less tolerance for noise during sleeping hours. The same occurs from 10 p.m. to midnight. The levels for the hourly periods between 7 p.m. and 10 p.m. have 5 added to them to represent a lessened tolerance for noise during evening activities. They are energy summed and converted to an average noise exposure rating.

The day-evening-night level L_{DEN} is defined by the following formula:

$$L_{DEN} = 10 \lg \left(\frac{1}{24} \right) \left[12 * 10^{\frac{L_{day}}{10}} + 4 * 10^{\frac{L_{evening+5}}{10}} + 8 * 10^{\frac{L_{night+10}}{10}} \right]$$

In the default form, the day has eight hours, the evening has four hours and the night has eight hours, as can be seen in the equation. The default times for these periods are as follows

- **Day: 07.00 to 19.00**
- **Evening: 19.00 to 23.00**
- **Night: 23.00 to 07.00**

L_{day} , $L_{evening}$ and L_{night} are A-weighted long-term average sound levels measured during the day, evening and night, respectively.

To account for the increased impact of environmental noise during the evening and night, penalties are added to the measured level; 5 dB for evening and 10 dB for night, as can be seen in the equation.

The Directive 2002/49/EC of the European Parliament and of the Council of 25 June 2002, relating to the assessment of environmental noise permits member states to shorten the evening period by one or two hours and lengthen the day and/or the night accordingly and also to choose the time for the start of the day.

To accommodate these and other possible modifications, the Day/Night page permits the user to modify the times for the beginning of the Day, Evening and Night periods and the penalties to be utilized when calculating 24-hour integrated values.

Day-Night Average Sound Level (DNL, L_{dn})

A rating of community noise exposure to all sources of sound that differentiates between daytime and nighttime noise exposure. The equation is

$$L_{dn} = 10 \log_{10} \left\{ \frac{1}{24} \left[\sum_{0000}^{0700} 10^{(L_i + 10)/10} + \sum_{0700}^{2200} 10^{L_i/10} + \sum_{2200}^{2400} 10^{(L_i + 10)/10} \right] \right\}$$

The continuous equivalent sound level (See definition) is generally calculated on an hourly basis and is shown in the equation as L .

The values for the hourly periods from midnight to 7 a.m. have 10 added to them to represent less tolerance for noise during sleeping hours. The same occurs from 10 p.m. to midnight. They are energy summed and converted to an average noise exposure rating.

Decibel (dB)

A logarithmic form of any measured physical quantity and commonly used in the measurement of sound. Whenever the word *level* is used, this logarithmic form is implied. The decibel provides us with the possibility of representing a large span of signal levels in a simple manner as opposed to using the basic pressure unit Pascal for acoustic measurements.

Decibel is the name; dB is the symbol.

It is not possible to directly add or subtract physical quantities when expressed in decibel form since the addition of logarithmic values correspond to multiplication of the original quantity.

The word *level* is normally attached to a physical quantity when expressed in decibels; for example, L_p represents the sound pressure level.

The difference between the sound pressure at the threshold of hearing versus loud sounds is a factor of 1,000,000:1 or more, and it is very unpractical to use these large numbers. Therefore, a measure that would relate to “the number of zeros” would help, for example, 100,000 would be equal to 50 and 1000 would be equal to 30 and so on. This is the basic principal of the decibel measure.

All decibel values are unit free and therefore, the decibel value is not the value of the quantity itself, but the ratio of that quantity to an actual reference quantity used. Thus, for every level in decibels there must be a well defined reference quantity.

When the quantity equals the reference quantity the decibel level is zero. To keep decibel values above zero, the reference is generally set to be the lowest value of the quantity that we can imagine or normally wish to use.

For sound, the reference level is chosen as $20 \mu\text{Pa}$, which is close to the threshold of human hearing.

Before explaining the calculation of decibel values, it is useful to remember the following rules of thumb when decibel values are used for sound levels:

- **Doubling of the Sound Pressure = 6 dB**
- **Doubling of the Sound Power = 3 dB**
- **Doubling of the Perceived Sound Level = (approximately) 10 dB**

Note: The latter is frequency and level dependent, but the value “10 dB” is a good rule of thumb, especially around 1 kHz.

Table 1 shows the actual value of a specific item, such as sound power, for which the sound level is calculated. First, the sound power value is divided with the reference used and then the ten-based logarithm is applied. This value is then multiplied by 10 to create the decibel value.

Table 1		
Power form, squared units		Level form
Ratio of Value to Reference	Exponential Form of Ratio	10•Exponent
1	10^0	0
10	10^1	10
100	10^2	20
200	$10^{2.3}$	23
1,000	10^3	30
10,000	10^4	40
100,000	10^5	50
1000,000	10^6	60

Each time the sound *pressure* level increases by 6 dB, the corresponding sound *pressure* value is doubled. Each time the sound *power* level increases by 3 dB, the sound *power* value is multiplied by 2. Thus, it is important to notice that a doubling of the *sound power* is equal to 3 dB, and a doubling of the sound pressure is equal to 6 dB, since a doubling of the sound pressure will result in a quadruple increase of the sound power.

Table 2		
Linear form, non-squared units		Level form
Ratio of Value to Reference	Exponential Form of Ratio	20•Exponent
1	10^0	0
10	10^1	20
100	10^2	40
200	$10^{2.3}$	46
1,000	10^3	60
10,000	10^4	80
100,000	10^5	100
1000,000	10^6	120

Department of Defense Level (L_{DOD})

The Average Sound Level calculated in accordance with Department of Defense Exchange Rate and Threshold Level. See Average Sound Level.

Dose

See *Noise Dose*.

Dose and Projected Dose Calculations

Dose is a measure of Sound Exposure and is defined in ANSI S1.25 Section 4.7 as:

$$D(Q) = \left(\frac{100}{T_c}\right) \cdot \int_0^T 10^{\left(\frac{L-L_c}{q}\right)} dt$$

See FIGURE C-1 "DOSE and Projected DOSE"

where:

$D(Q)$ is the percentage criterion exposure for exchange rate Q

T_c is the criterion sound duration

T is the measurement duration in hours

t is the time in hours

L is the SLOW, (or FAST) A-weighted sound level, a function of time, when the sound level is greater than or equal to L_t , or equals $-\infty$ when the A-weighted sound level is less than L_t

L_t is the threshold sound level specified by the manufacturer

L_c is the criterion sound level specified by the manufacturer

Q is the exchange rate in dB, and q = the parameter that determines the exchange rate, where:

$q = 10$ for a 3 dB exchange rate

$q = 13.29 = 4/\log(2)$ for a 4 dB exchange rate

$q = 16.61 = 5/\log(2)$ for a 5 dB exchange rate

$q = 20 = 6/\log(2)$ for a 6 dB exchange rate

The factor of 100 in the equation produces a result that is a percentage.

Dose is obtained from the accumulations made for TWA and SEL using the formula:

$$DOSE = 10 \left[\log \left(\sum_{s=1}^n 10^{\frac{L(s)}{k}} \right) - \frac{L_c}{k} - \log(T_c 115200) + \log(100) \right] \%$$

where,

$L_{(s)}$ is the current SPL at sample s ; for measurements that include a threshold $L_{(s)}$ is set to \times if $L_{(s)}$ is less than the Threshold Level L_t

k is the exchange rate constant.

n is the total number of samples taken in the measurement. The sample rate is 32 samples per second.

T_c is the criterion sound duration as set by the LxT's "Criterion Time Hours" setting which by default is set to 8 hours L_c is the criterion sound level as set by the LxT's "Overall Criterion" or "Current Criterion" settings.

Addition of the term "log(100)" was used to implement the 100 multiplier of the ANSI equation that creates the percentage. Subtracting the log of the Criterion Time was used to implement the division of Criterion Time of the ANSI equation.

Projected Dose in the analyzer is obtained with an equation similar to that of Dose except that the actual duration (time) of the measurement is used rather than a Criterion Time, as shown:

$$\text{PROJDOSE} = 10 \left[\log \left(\sum_{s=1}^n 10^{\frac{L(s)}{k}} \right) - \frac{L_C}{k} - \log(n) + \log(100) \right] \%$$

where the $\log(n)$ is the actual time factor, n being the total number of samples taken.

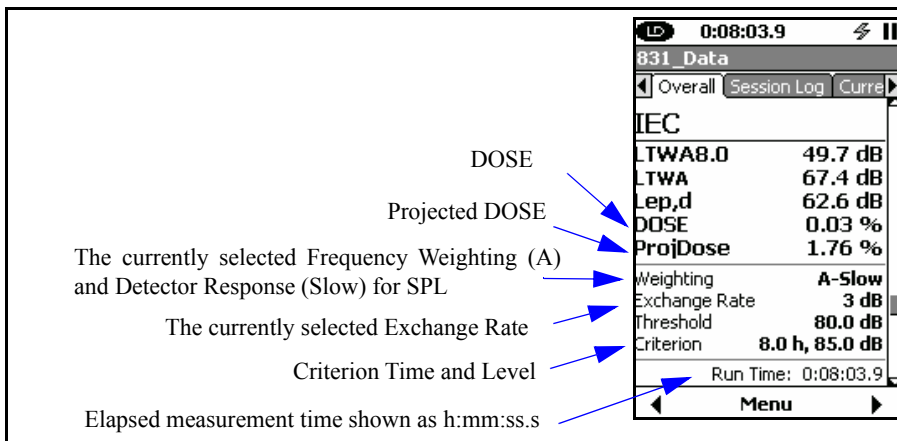

FIGURE C-1 DOSE and Projected DOSE

Detector

The part of a sound level meter that converts the actual fluctuating sound or vibration signal from the microphone to one that indicates its amplitude. It first squares the signal, then averages it in accordance with the time-weighting characteristic, and then takes the square root. This results in an amplitude described as rms (root-mean-square), commonly called *Time Weighting*.

Eight Hour Time-Weighted Average Sound Level (L_{TWA(8)})

The constant sound level that would expose a person to the same Noise Dose as the actual (unsteady) sound levels. The equation for it is

$$L_{TWA(8)} = L_c + q \text{Log}_{10} \left(\frac{D}{100} \right)$$

L_c = Criterion Sound Level

q = Exchange Rate Factor

D = Noise dose in percent

NOTE: This definition applies only for a Criterion Duration of 8 hours. *Standard: ANSI S12.19*

Equivalent Continuous Sound Level

The LxT displays the equivalent continuous A-weighted sound pressure level as L_{Aeq}

Continuous

The Larson Davis SoundTrack LxT[®] calculates equivalent continuous sound levels based on equations from IEC standard 61672-1, Section 3.9 which defines L_{eq} as follows:

Equivalent continuous A-weighted sound pressure level (also average A-weighted sound pressure level) is defined as follows:

$$L_{AT} = L_{AeqT} = 20 \lg \left\{ \left[\left(\frac{1}{T} \right) \int_{t-T}^t P_A^2(\xi) d\xi \right]^{1/2} / P_0 \right\} dB$$

where:

L_{AeqT} is the equivalent continuous A-weighted sound pressure level re 20 μPa, determined over a time interval T

ξ is a dummy variable of time integration over the averaging time interval ending at the time of observation t

T is the averaging time interval

$p_A(\xi)$ is the A-weighted sound pressure

p_0 is the reference sound pressure of 20 μPa

In the equation, the numerator of the argument of the logarithm is the root-mean-square, frequency-weighted sound pressure level over the averaging time interval T.

The format used by the LxT to display equivalent continuous sound pressure level is L_{Xeq} , where X is the frequency weighting (X = A, C or Z).

When a frequency weighting other than A is used, the frequency weighting used shall be included explicitly in the title and the formula of the quantity, for example equivalent continuous C-weighted sound pressure level:

$$L_{CT} = L_{CeqT} = 20 \lg \left\{ \left[\left(\frac{1}{T} \right) \int_{t-T}^t P_C^2(\xi) d\xi \right]^{1/2} / P_0 \right\} dB$$

If no frequency weighting is used, the quantity is simply called equivalent continuous sound pressure level.

**Exchange Rate (Q),
Exchange Rate Factor (q),
Exposure Factor (k)**

It is defined in ANSI S1.25 as “the change in sound level corresponding to a doubling or halving of the duration of a sound level while a constant percentage of criterion exposure is maintained.” The rate and the factors are given in the table below.

Standard: ANSI S12.19

Exchange Rate, Q	Exchange Rate Factor, q	Exposure Factor, k
3.01	10	1
4	13.333	.75
5	16.667	.60
6.02	20	.50

Far Field

There are two types of far fields: the *acoustic* far field and the *geometric* far field.

Acoustic Far Field: The distance from a source of sound is greater than an acoustic wavelength. In the acoustic far field, the effect of the type of sound source is negligible. Since the wavelength varies with frequency (See the definition of Wavelength), the distance will vary with frequency. To be in

the far field for all frequencies measured, the lowest frequency should be chosen for determining the distance.

For example, if the lowest frequency is 20 Hz, the wavelength at normal temperatures is near 56 ft. (17 m); at 1000 Hz, the wavelength is near 1.1 ft. (1/3 m). See the definition of Acoustic Near Field for the advantages of the acoustic far field.

Geometric Far Field: The distance from a source of sound is greater than the largest dimension of the sound source. In the geometric far field, the effect of source geometry is negligible. Sound sources often have a variety of specific sources within them, such as exhaust and intake noise. When in the far field, the sources have all merged into one, so that measurements made even further away will be no different. See the definition of Geometric Near Field for the advantages of being in the geometric far field.

Free Field

A sound field that is *free* of reflections. This does not mean that the sound is all coming from one direction as is often assumed, since the source of sound may be spatially extensive. See the definitions of near and far fields for more detail. This definition is often used in conjunction with reverberant field.

Frequency (Hz, rad/sec)

The rate at which an oscillating signal completes a complete cycle by returning to the original value. It can be expressed in cycles per second and the value has the unit symbol Hz (Hertz) added and the letter f is used for a universal descriptor. It can also be expressed in radians per second, which has no symbol, and the Greek letter ω is used for a universal descriptor. The two expressions are related through the expression $\omega=2\pi f$.

Frequency Filter

The part of certain sound level meters that divides the frequency spectrum of the sound into a part that is unchanged and a part that is filtered out. It can be composed of one or more of the following types:

Low Pass: A frequency filter that permits signals to pass through that have frequencies below a certain fixed frequency, called a *cutoff frequency*. It is used to remove higher frequencies.

High Pass: A frequency filter that permits signals to pass through that have frequencies above a certain fixed frequency, called a *cutoff frequency*. It is used to remove lower frequencies.

Bandpass: A frequency filter that permits signals to pass through that have frequencies above a certain fixed frequency, called a lower cutoff frequency, and below a certain fixed frequency, called an *upper cutoff frequency*. The difference between the two cutoff frequencies is called the *bandwidth*. It is used to discriminate against both lower and higher frequencies so it passes only a band of frequencies.

Octave band: A bandpass frequency filter that permits signals to pass through that have a bandwidth based on octaves. An *octave* is a doubling of frequency so the upper cutoff frequency is twice the lower cutoff frequency. This filter is often further subdivided in 1/3 and 1/12 octaves (3 and 12 bands per octave) for finer frequency resolution. Instruments with these filters have a sufficient number of them to cover the usual range of frequencies encountered in sound and vibration measurements. The frequency chosen to describe the band is that of the center frequency.

Frequency Filter - Weighted

A special frequency filter that adjusts the amplitude of all parts of the frequency spectrum. It can be composed of one or more of the following types:

A-Weighting: A filter that adjusts the levels of a frequency spectrum in a way similar to what the human ear does when exposed to low levels of sound. This weighting is most often used for evaluation of environmental sounds. See table below.

B-Weighting: A filter that adjusts the levels of a frequency spectrum in a way similar what the human ear does when exposed to moderate levels of sound. This weighting is seldom used. See table below.

C-Weighting: A filter that adjusts the levels of a frequency spectrum in a way similar to what the human ear does when exposed to high levels of sound. This weighting is most often used for evaluation of equipment sounds. See table below.

Flat-Weighting, or z-weighting: A filter that does not adjust the levels of a frequency spectrum. It is usually an alternative selection for the frequency-weighting selection.

Center Frequencies, Hz		Weighting Network Frequency Response		
1/3 Octave	1 Octave	A	B	C
20		-50.4	-24.2	-6.2
25		-44.7	-20.4	-4.4
31.5	31.5	-39.4	-17.1	-3.0
40		-34.6	-14.2	-2.0
50		-30.2	-11.6	-1.3
63	63	-26.2	-9.3	-0.8
80		-22.5	-7.4	-0.5
100		-19.1	-5.6	-0.3
125	125	-16.1	-4.2	-0.2
160		-13.4	-3.0	-0.1
200		-10.9	-2.0	0
250	250	-8.6	-1.3	0
315		-6.6	-0.8	0
400		-4.8	-0.5	0
500	500	-3.2	-0.3	0
630		-1.9	-0.1	0
800		-0.8	0	0
1000	1000	0	0	0
1250		0.6	0	0
1600		1.0	0	-0.1
2000	2000	1.2	-0.1	-0.2
2500		1.3	-0.2	-0.3
3150		1.2	-0.4	-0.5
4000	4000	1.0	-0.7	-0.8
5000		0.5	-1.2	-1.3
6300		-0.1	-1.9	-2.0
8000	8000	-1.1	-2.9	-3.0
10000		-2.5	-4.3	-4.4
12500		-4.3	-6.1	-6.2
16000	16000	-6.6	-8.4	-8.5
20000		-9.3	-11.1	-11.2

L_{eq}

See “Equivalent Continuous Sound Level.”

Measurement Duration (T)

The time period of measurement. It applies to hearing damage risk and is generally expressed in hours.
Standard: ANSI S12.19

Microphone Guidelines

Microphone Types: A device for detecting the presence of sound. Most often it converts the changing pressure associated with sound into an electrical voltage. It can be composed of one of the following types:

Capacitor (Condenser): A microphone that uses the motion of a thin diaphragm caused by the sound to change the capacitance of an electrical circuit and thereby to create a signal.

Prepolarized: A microphone that uses the motion of a thin diaphragm caused by the sound to change the capacitance of an electrical circuit and thereby to create a signal. The voltage across the diaphragm is caused by the charge embedded in the electric material so no external source is needed.

Microphone Uses: The frequency response of microphones can be adjusted to be used in specific applications. Among those used are:

Frontal incidence (Free Field): The microphone has been adjusted to have an optimally flat frequency response when in a space optimally free of reflections and when pointed at the source of the sound.

Random incidence: The microphone has been adjusted to have an optimally flat frequency response for sound waves impinging on the microphone from all directions.

Pressure: The microphone has not been adjusted to have an essentially flat frequency response for sound waves impinging on the microphone from all directions.

What a microphone measures: A microphone detects more than just sound. The motion of a microphone diaphragm is in response to a force acting on it. The force can be caused by a number of sources only one of which are we interested: sound. Non-sound forces are: (1) direct physical contact such as that with a finger or a raindrop; (2) those caused by the movement of air over the diaphragm such as environmental wind or blowing; (3) those caused by vibration of the microphone housing; and (4) those caused by strong electrostatic fields.

Guidelines:

1. Do not permit any solid or liquid to touch the microphone diaphragm. Keep a protective grid over the diaphragm.
2. Do not blow on a microphone and use a wind screen over the microphone to reduce the effect of wind noise.
3. Mount microphones so their body is not subject to vibration, particularly in direction at right angles to the plane of the diaphragm.
4. Keep microphones away from strong electrical fields.

A microphone measures force, not pressure. We would like a microphone to measure sound pressure (force per unit area) instead of sound force. If the pressure is applied uniformly over the microphone diaphragm a simple constant (the diaphragm area) relates the two, but if the pressure varies across the diaphragm the relationship is more complex. For example, if a negative pressure is applied on one-half the diaphragm and an equal positive pressure is applied to the other half, the net force is zero and essentially no motion of the diaphragm occurs. This occurs at high frequencies and for specific orientations of the microphone.

Rules:

1. Do not use a microphone at frequencies higher than specified by the manufacturer; to increase the frequency response choose smaller microphones.
2. Choose a microphone for free field or random incidence to minimize the influence of orientation.

A microphone influences the sound being measured. The microphone measures very small forces, low level sound can be about one-billionth of a PSI.

Every measurement instrument changes the thing being measured, and for very small forces that effect can be significant. When sound impinges directly on a microphone the incident wave must be reflected since it cannot pass through the microphone. This results in the extra force required to reflect the sound and a microphone output that is higher than would exist if the microphone were not there. This is more important at high frequencies and when the microphone is facing the sound source.

A microphone measures sound from any direction: Most measurements are intended to measure the sound level of a specific source, but most microphones are not directional so they measure whatever is there, regardless of source.

When making hand-held measurements, keep your body at right angles to the direction of the sound you are interested in and hold the meter as far from your body as possible. Use a tripod whenever possible.

Measure the influence of other sources by measuring the background sound level without the source of interest. You may have to correct for the background.

Near Field

There are two types of near fields: the *acoustic near field* and the *geometric near field*.

Acoustic Near Field: The distance from a source of sound is less than an acoustic wavelength. In the acoustic near field, the effect of the type of sound source is significant. Because wavelength varies with frequency, the distance will vary with frequency. The most common example of a near field is driving an automobile with an open window. As you move your ear to the plane of the window, the sound pressure level builds up rapidly (wind noise) since most of the pressure changes are to move the air and very little of it compresses the air to create sound. Persons not far way, can hardly hear what you hear. The acoustic near field is characterized by pressures that do not create sound that can be measured in the far field. Therefore measurements made here are not useful in predicting the sound levels far way or the sound power of the source.

Geometric Near Field: The distance from a source of sound is less than the largest dimension of the sound source. In the geometric near field, effect of source geometry is significant. Sound sources often have a variety of specific sources within them, such as exhaust and intake noise. When in the geometric near field, the sound of a weaker, but closer, source can be louder than that of a more distant, but stronger, source. Therefore measurements made here can be used to separate the various sources of sound, but are not useful in predicting the sound levels and sound spectrum far from the source.

Noise

Typically is *unwanted* sound. This word adds the response of humans to the physical phenomenon of sound. The descriptor should be used only when negative effects on people are known to occur.

Ambient: The all encompassing sound at a given location caused by all sources of sound. It is generally random, but need not be.

Background: The all encompassing sound at a given location caused by all sources of sound, but excluding the source to be measured.

Pink: A random sound that maintains constant energy per octave. Pink light is similar to pink noise in that it has a higher level at the lower frequencies (red end of the spectrum).

White: A random sound that contains equal energy at each frequency. In this respect, it is similar to white light.

Noise Dose (D)

Dose is a measure of Sound Exposure and is defined in ANSI S1.25 Section 4.7 as:

$$D(Q) = \left(\frac{100}{T_c}\right) \cdot \int_0^T 10^{\left(\frac{L-L_c}{q}\right)} dt$$

See FIGURE C-1 "DOSE and Projected DOSE"

where:

D(Q) is the percentage criterion exposure for exchange rate Q

T_c is the criterion sound duration.

T is the measurement duration in hours.

t is the time in hours.

L is the SLOW, (or FAST) A-weighted sound level, a function of time, when the sound level is greater than or equal to L_t, or equals -∞ when the A-weighted sound level is less than L_t.

L_t is the threshold sound level.

L_C is the criterion sound level.

Q is the exchange rate in dB, and $q =$ the parameter that determines the exchange rate, where:

$q = 10$ for a 3 dB exchange rate.

$q = 13.29 = 4/\log(2)$ for a 4 dB exchange rate.

$q = 16.61 = 5/\log(2)$ for a 5 dB exchange rate.

$q = 20 = 6/\log(2)$ for a 6 dB exchange rate.

The factor of 100 in the equation produces a result that is a percentage.

Dose is obtained from the accumulations made for TWA and SEL using the formula:

$$DOSE = 10 \left[\log \left(\sum_{s=1}^n 10^{\frac{L(s)}{k}} \right) - \frac{L_c}{k} - \log(T_c 115200) + \log(100) \right] \%$$

where,

$L(s)$ is the current SPL at sample s ; for measurements that include a threshold $L(s)$ is set to \times if $L(s)$ is less than the Threshold Level L_t

k is the exchange rate constant.

n is the total number of samples taken in the measurement. The sample rate is 32 samples per second.

T_c is the criterion sound duration as set by the LxT's "Criterion Time Hours" setting which by default is set to 8 hours L_c is the criterion sound level as set by the LxT's "Overall Criterion" or "Current Criterion" settings.

Addition of the term "log(100)" was used to implement the 100 multiplier of the ANSI equation that creates the percentage. Subtracting the log of the Criterion Time was used to implement the division of Criterion Time of the ANSI equation.

Projected Dose in the analyzer is obtained with an equation similar to that of Dose except that the actual duration (time) of the measurement is used rather than a Criterion Time, as thus:

$$\text{PROJDOSE} = 10 \left[\log \left(\sum_{s=1}^n 10^{\frac{L(s)}{k}} \right) - \frac{L_c}{k} - \log(n) + \log(100) \right] \%$$

See Standard: ANSI S12.19

where the $\log(n)$ is the actual time factor, n being the total number of samples taken.

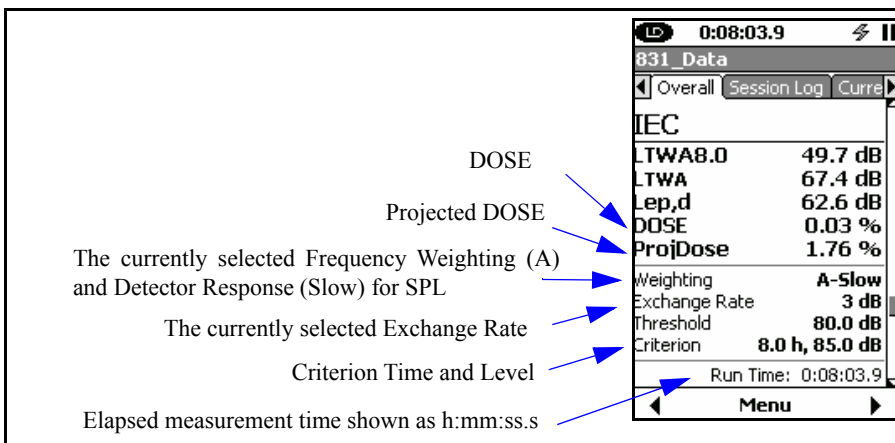

FIGURE C-2 DOSE and Projected DOSE

Noise Exposure	(See Sound Exposure)
OSHA Level (L_{OSHA})	The Average Sound Level calculated in accordance with the Occupational Safety and Health Administration Exchange Rate and Threshold Level.
Preamplifier	A part of the sound level meter that matches a particular model of microphone to the meter. It must be chosen in conjunction with a microphone and a cable that connects them.
Projected Noise Dose	The Noise Dose expected if the current rate of noise exposure continues for the full Criterion Duration period.
Single Event Noise Exposure Level ($SENEL, L_{AX}$)	The total sound energy over a specific period. It is a special form of the Sound Exposure Level where the time period is defined as the start and end times of a noise event such as an aircraft or automobile passing.
Sound	<p>The rapid oscillatory compressional changes in a medium (solid, liquid or gas) that propagate to distant points. It is characterized by changes in density, pressure, motion, and temperature as well as other physical quantities. Not all rapid changes in the medium are sound (wind noise) since they do not propagate.</p> <p>The auditory sensation evoked by the oscillatory changes.</p> <p><i>Difference between sound and noise:</i> Sound is the physical phenomenon associated with acoustic (small) pressure waves. Use of the word <i>sound</i> provides a neutral description of some acoustic event. Generally, noise is defined as unwanted sound. It can also be defined as sound that causes adverse effects on people such as hearing loss or annoyance. It can also be defined as the sound made by other people. In every case, noise involves the judgment of someone and puts noise in the realm of psychology, not physics.</p> <p><i>Rules:</i></p> <ol style="list-style-type: none"> 1. Use word <i>sound</i> to describe measurements to remove the connotations associated with the word <i>noise</i>. Some sound metrics use noise in their name and it is proper to use the name as it is.

Sound Exposure (SE)

The total sound energy of the actual sound during a specific time period. It is expressed in Pascal-squared seconds.

$$SE = \int_{T_1}^{T_2} p_A^2(t) dt$$

where p_A is the instantaneous sound pressure and $T_2 - T_1$ is the Measurement Duration (specific time period).

The LxT displays Sound Exposure as E_X , where X is the frequency weighting (X=A, C or Z).

When applied to hearing damage potential, the equation is changed to

$$SE = \int_{T_1}^{T_2} [p_A^2(t)]^k dt$$

where k is the Exposure Factor. See Exchange Rate.
Standard: ANSI S1.25.

Sound exposure and sound exposure level are calculated as specified in IEC 61672-1.

The A-weighted sound exposure E_A of a specified event is represented by

$$E_A = \int_{t_1}^{t_2} p_A^2(t) dt$$

where $P_A^2(t)$ is the square of the A-weighted instantaneous sound pressure during an integration time starting at t_1 and ending at t_2 .

The unit of A-weighted sound exposure is pascal-squared seconds if A-weighted sound pressure is in pascals and running time is in seconds. However it is sometimes expressed in pascal-squared hours for measurements of noise exposure in the workplace.

SEL Calculations

The LxT displays SEL as L_{XE} , where X is the frequency weighting (X = A, C or Z).

SEL is available for the overall measurement and is calculated using this formula:

$$SEL = 10 \text{Log}_{10} \left[\frac{\int_{T_1}^{T_2} p^2(t) dt}{p_0^2 T} \right]$$

Alternatively, SEL can also be calculated with this formula:

$$SEL = k \cdot \log \left(\sum_{s=1}^n 10^{\frac{L(s)}{k}} \right) - \log(32)$$

All of the SEL energy values in the sound level meter utilize the Threshold and Exchange Rate settings. Care should be taken when modifying these settings since some standards or governments require SEL to be taken without a Threshold (set it to zero) and with an Exchange Rate of 3 dB.

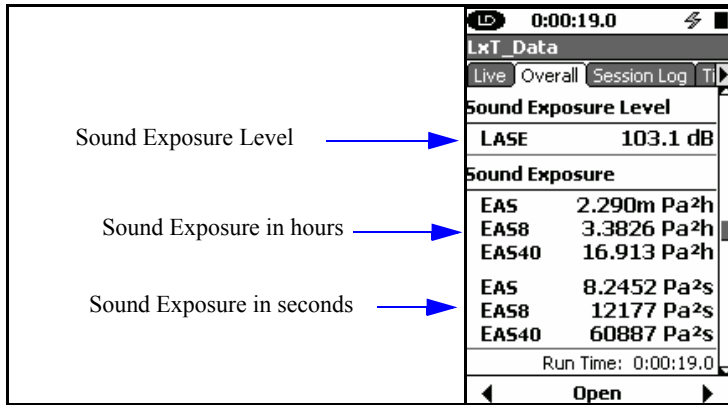

FIGURE C-3 Sound Exposure Level and Sound Exposure

Sound Exposure Level (SEL, L_E)

The total sound energy in a specific time period.

The sound pressure is squared and integrated over a specific period of time (T_2-T_1) this is called the sound exposure and has the units Pascal squared- seconds or Pascal squared-hours. P_0 is the reference pressure of 20 μ Pa and T is the reference time of 1 second. It is important to note that it is not an average since the reference time is not the same as the integration time.

The A-weighted sound exposure level L_{AE} is related to a corresponding measurement of time-average, A-weighted sound level, L_{AT} or L_{AEeqT} , by

$$L_{AE} = 10 \lg \left\{ \left[\int_{t_1}^{t_2} p_A^2(t) dt \right] / (p_0^2 T_0) \right\} dB = 10 \lg (E_A / E_0) dB = L_{AT} + 10 \lg (T / T_0) dB$$

where

E_A is the A-weighted sound exposure in pascal-squared seconds

E_0 is the reference sound exposure of:

$$(20 \mu\text{Pa})^2 \times 1\text{s} = 400 \times 10^{-12} \text{ Pa}^2\text{s}$$

$$T_0 = 1 \text{ s}$$

$T = t_2 - t_1$, the time interval for measurement, in seconds, for sound exposure level and time-average sound level

SEA

The SEA parameter is used mainly in the Canadian province of Quebec. It is based on the theory that impulsive sounds above 120 dBC have an effect on hearing loss which is in addition to the that caused by non-impulsive noises. It calls for the calculation of the parameter L_{eq} (peak value) which is calculated as follows:

$$L_{eq} \text{ (peak value)} = 10 \log_{10} \frac{1}{N} \sum_{n=0}^N 10^{L_n/10}$$

The value of SEA is then determined as follows:

:

$$SEA = L_{eq} \text{ (peak value)} + 10 \log_{10} N$$

Where :

SEA = Acoustical Energy Sum

L_{eq} (peak value) = Equivalent level of impact noises

L_n = PeakC level of the nth impact noise

N = Total number of seconds with an impact noises to which the worker is exposed during one working day

n = number of impact noises for each level of impact noise over 120 dBC, evaluated once per second

(impact noise below 120 dBC are not considered)

Examples of results:

SEA = 160 dB for 100 impact noises at 140 dBC

SEA = 160 dB for 200 impact noises at 137 dBC

SEA = 137,78 dB for 6 impact noises at 130 dBC

The formula implemented in the LxT is a simplification of the above:

$$SEA = 10 \log_{10} \sum_{n=0}^N 10^{L_n/10}$$

Sound Pressure

The physical characteristic of sound that can be detected by microphones. Not all pressure signals detected by a microphone are sound (e.g., wind noise). It is the amplitude of the oscillating sound pressure and is measured in Pascals (Pa).

Sound Pressure Level (SPL, L_p)

The logarithmic form of sound pressure. It is also expressed by attachment of the word decibel to the number. The logarithm is taken of the ratio of the actual sound pressure to a reference sound pressure which is 20 MicroPascals (μ Pa). There are various descriptors attached to this level depending on how the actual sound pressure is processed:

Sound Power(W)

The sound power emitted by a sound source. It is measured in Watts.

Sound Power Level (PWL, L_w)

The logarithmic form of sound power. It is also expressed by attachment of the word decibel to the number. The logarithm is taken of the ratio of the actual sound power to a reference sound power, which is 1 pico-watt. Sound power level cannot be measured directly, but can only be deduced through measurements of sound intensity or sound pressure around the source. The equation for it is

$$L_w = 10 \log_{10} \left[\frac{W}{W_0} \right] \quad W = W_0 10^{L_w/10}$$

Sound Speed, (c)

The speed at which sound waves propagate. It is measured in meters per second. It should not be confused with sound or particle velocity which relates to the physical motion of the medium itself.

$$c = 49.03 \sqrt{\text{degF} + 460} \quad \text{ft/sec}$$

$$c = 20.05 \sqrt{\text{degC} + 273} \quad \text{m/sec}$$

Spectrum (Frequency Spectrum)

The amplitude of sound or vibration at various frequencies. It is given by a set of numbers that describe the amplitude at each frequency or band of frequencies. It is often prefixed with a descriptor that identifies it such as sound pressure spectrum. It is generally expressed as a spectrum level.

Threshold Sound Level (Lt)

The A-weighted sound level below which the sound produces little or no Noise Dose accumulation and may be disregarded. It is used for hearing damage risk assessment.

Standard: ANSI S1.25

Time-Weighted Averages

The Larson Davis LxT calculates many time-integrated levels or time-weighted averages (TWA) based on different parameters and time intervals. They are all designed and programmed to perform the equation specified in IEC 61672-1 with allowances for the following:

A, C and Flat frequency weighting characteristics

Various interval times, both fixed interval TWAs and variable interval event TWAs

Exchange-rates, or “doubling rates” affect certain TWA measurements

Certain TWA measurements include a programmable threshold with only levels above this threshold contributing to the measurement

The following figure indicates how the requirements are met in the LxT.

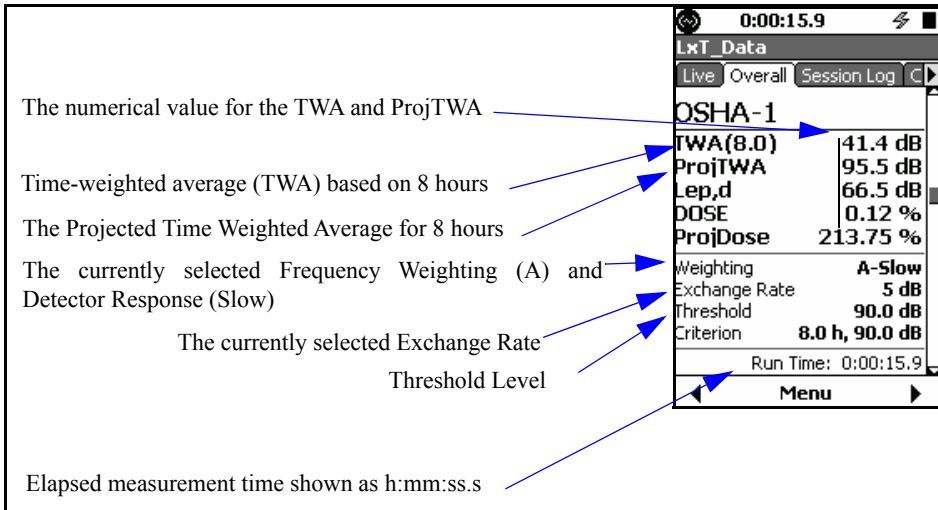

FIGURE C-4 TWA

The LxT displays the time weighted average as TWA[Hr] where Hr is the time in hours over which the average is performed.

The actual equations used within the LxT are implemented according to this equation:

$$L_{TWA} = k \cdot \log \left(\sum_{s=1}^n 10^{\frac{L_{(s)}}{k}} \right) - \log(n)$$

where:

$L_{(s)}$ is the current sound pressure level at sample s (for measurements that include a threshold, $L_{(s)}$ is set to $-\infty$ if $L_{(s)}$ is less than the Threshold Level L_t)

k is the exchange rate constant which is equal to:

10.00 for an exchange rate of 3 dB (L_{eq})

13.29 for an exchange rate of 4 dB (L_{DOD})

16.61 for an exchange rate of 5 dB (L_{OSHA})

20.00 for an exchange rate of 6 dB (L_{Avg})

n is the total number of samples taken in the measurement.
The sample rate is 32 samples per second.

Time Weighting

The response speed of the detector in a sound level meter. There are several speeds used.

Slow: The time constant is 1 second (1000 ms). This is the slowest and is commonly used in environmental noise measurements.

Fast: The time constant is 1/8 second (125 ms). This is a less commonly used weighting but will detect changes in sound level more rapidly.

Impulse: The time constant is 35ms for the rise and 1.5 seconds (1500 ms) for the decay. The reason for the double constant is to allow the very short signal to be captured and displayed.

Wavelength (λ)

The distance between peaks of a propagating wave with a well defined frequency. It is related to the frequency through the following equation

$$\lambda = \frac{c}{f}$$

where c is the sound speed and f is the frequency in Hz. It has the dimensions of length.